

Automotive Sensor Solutions

William Park, Ian Lee

Texas Instruments Korea

Temperature Sensor

Temperature Sensors

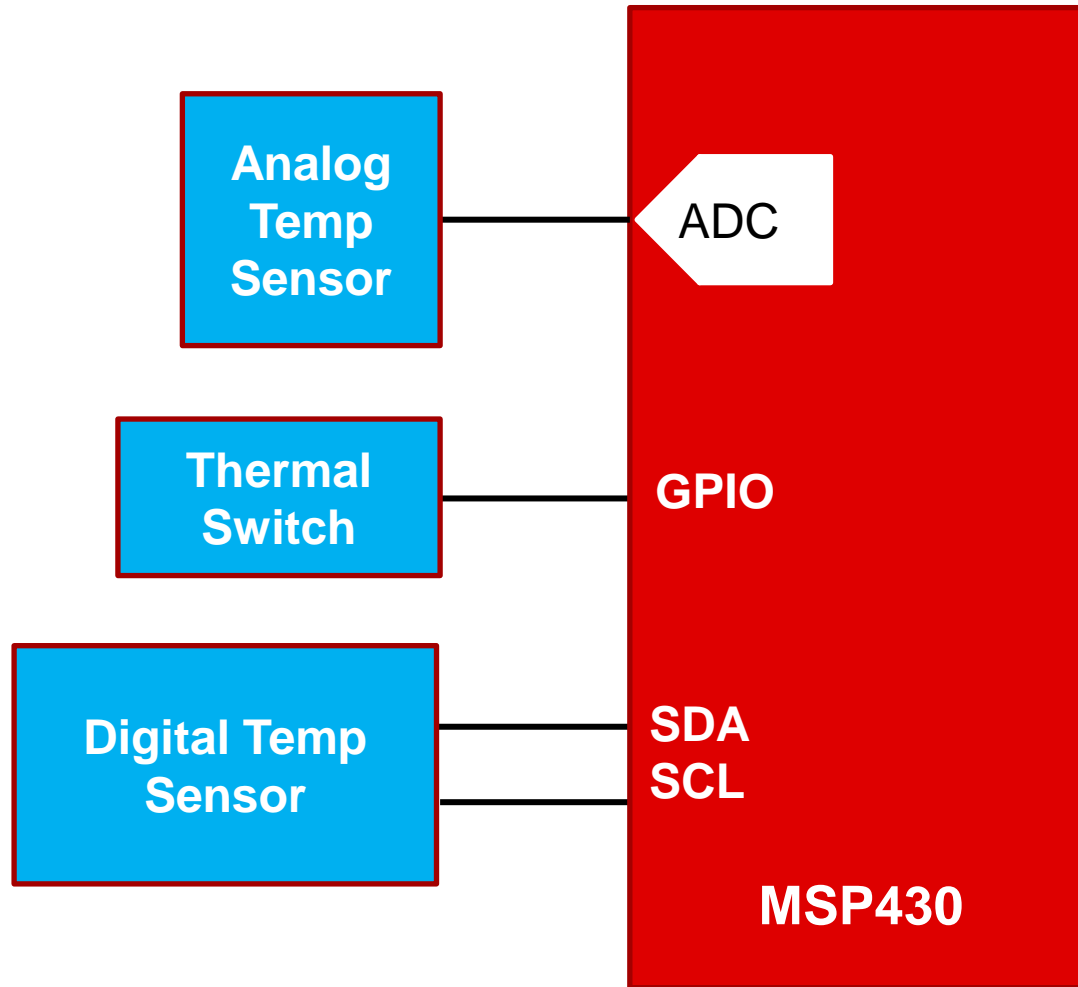

Why TI Temp Sensors:

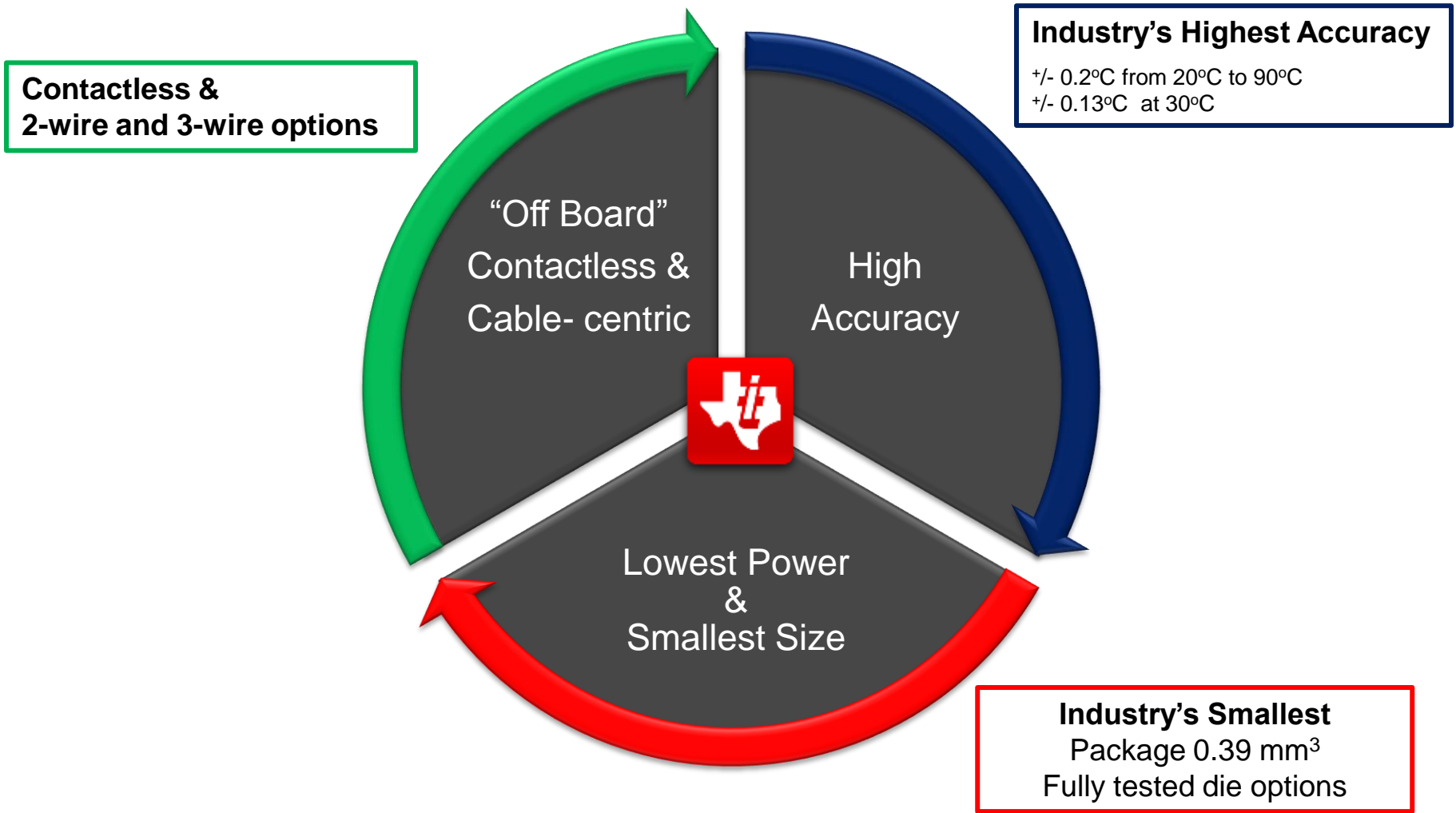

Comparison of Temperature Sensor Types

Criteria	Temp Sense IC	Thermistor	RTD	Thermocouple	IR Temp Sensor
Temp Range	-55°C to +150°C	-100°C to +500°C	-240°C to 700°C	-267°C to +2316°C	-100°C to +500°C
Accuracy	Good	Depends on Calibration	Best	Good	Depends on Calibration
Linearity	Best	Least	Better	Better	Better
Sensitivity	Better	Best	Less	Least	Less
Circuit Simplicity	Simplest	Simpler	Complex	Complex	Simple to Complex
Power	Lowest	Low	High	High	Medium
Cost	\$	\$ - \$\$\$	\$\$\$	\$\$	\$\$

Temp Sensors for Powertrain

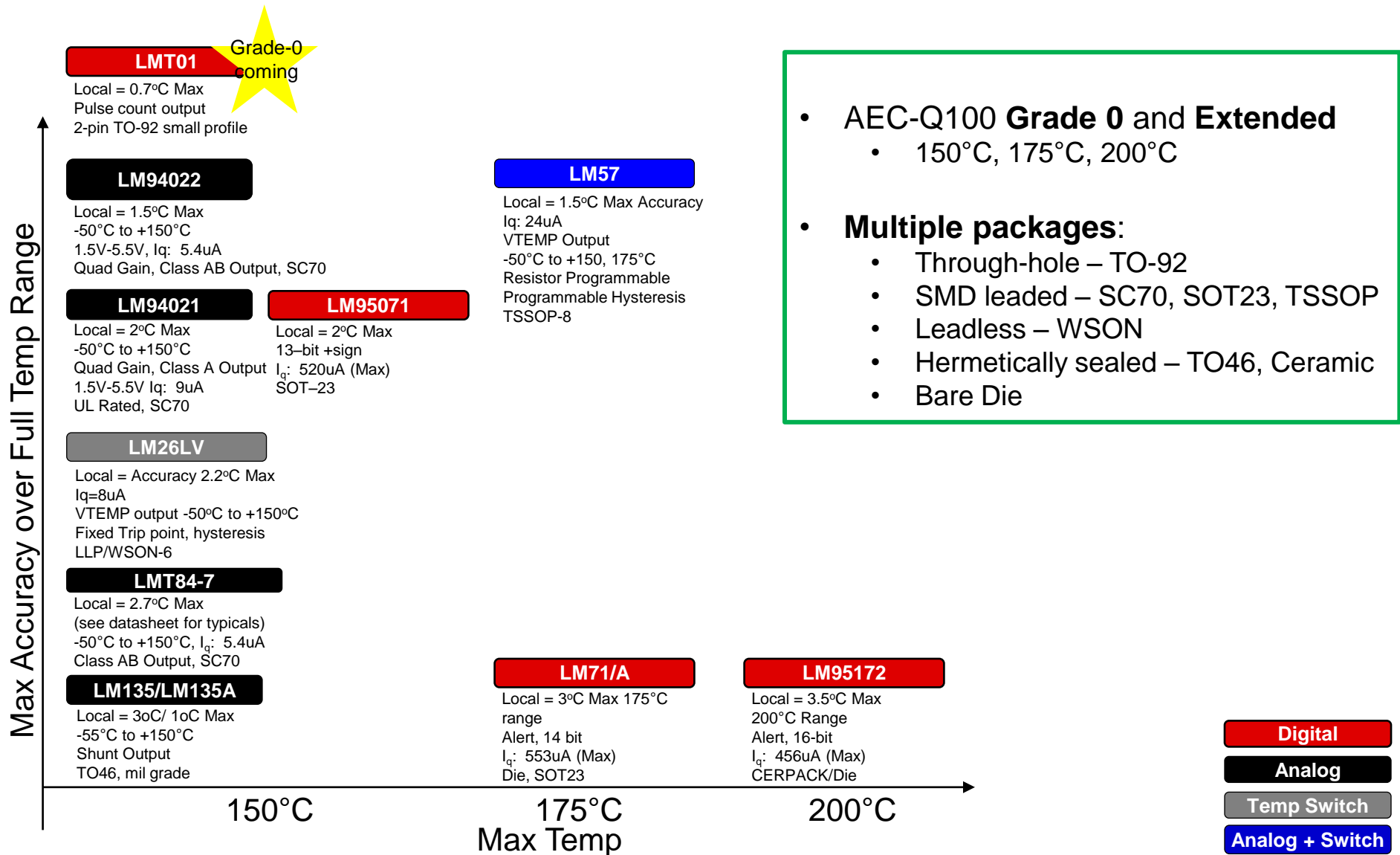

LMT87 / LMT87-Q1: SC70, Analog Temperature Sensor with Push-Pull Output

Features

Supply Voltage 2.7V to 5.5V

Supply Current 5.4 μA (typ)

Gain: $-13.6\text{mV}/^\circ\text{C}$

Operating Temperature -50°C to 150°C

Accuracy

Conditions	Typ	Max
70°C to 150°C , 3.0V to 5.5V	$\pm 0.4^\circ\text{C}$	$\pm 2.7^\circ\text{C}$
20°C to 40°C , 2.7V to 5.5V	$\pm 0.6^\circ\text{C}$	$\pm 2.7^\circ\text{C}$
20°C to 40°C , 3.4V to 5.5V	$\pm 0.3^\circ\text{C}$	
0°C , 3.0V to 5.5V	$\pm 0.3^\circ\text{C}$	
-50°C , 3.6V to 5.5V	$\pm 0.6^\circ\text{C}$	$\pm 2.7^\circ\text{C}$

Applications

- Automotive
- White Goods
- Industrial
- Battery Management
- Disk Drives
- Games
- Appliances

Benefits

- Output is short-circuit protected
 - Very low power consumption
 - Minimal real-estate and easy-to-use
 - Wide range of applications
 - Wide accuracy range
-
- LMT87-Q1 grade 0 AEC-Q100

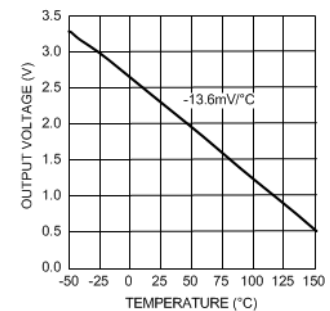
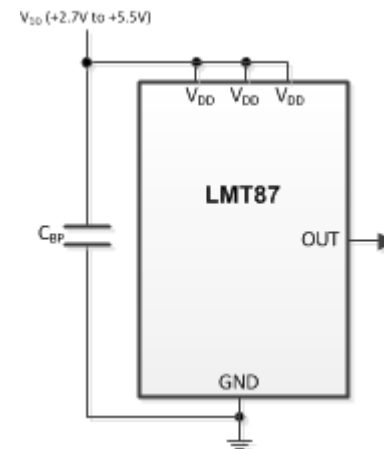

LMT8x Accuracy

- Accuracy is very linear for 96 units plotted
 - LMT85/LM86/LM87 have similar performance
- $\pm 2.7^{\circ}\text{C}$ Max and Min Limits support VDD:
 - 1.5V to 5.5V for LMT84
 - 1.8V to 5.5V for LMT85
 - 2.2V to 5.5V for LMT86
 - 2.7V to 5.5V for LMT87

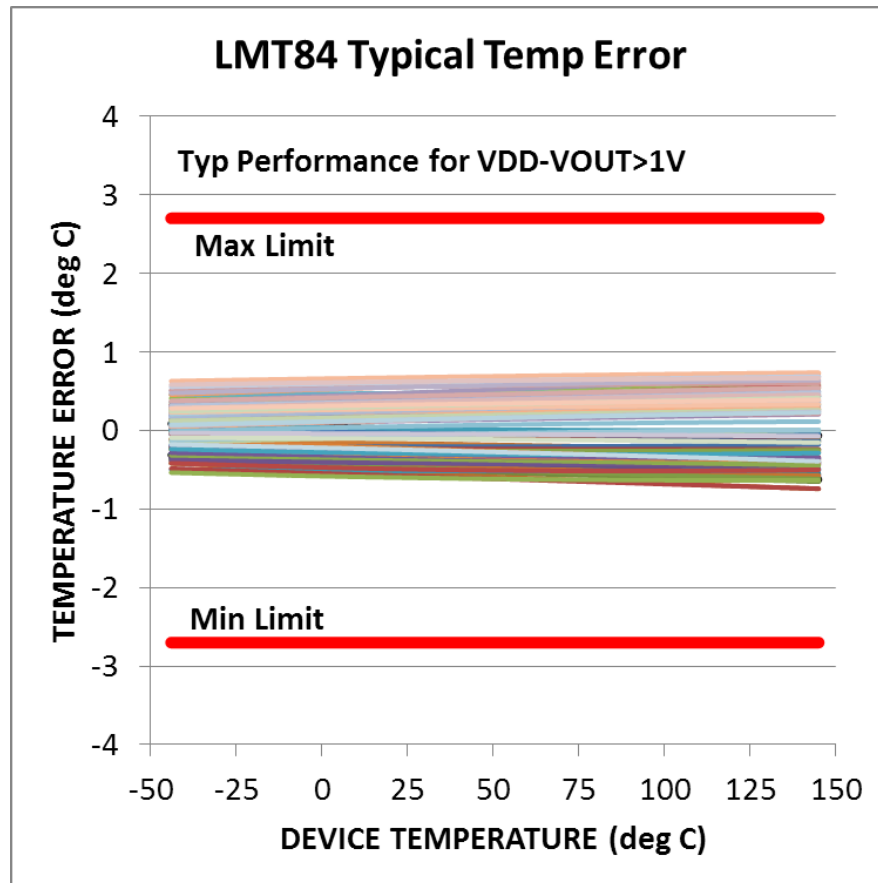

Less Noise Sensitivity LMT8x vs NTC

Advantages over thermistor solution:

- ✓ Noise-immunity
 - Devices attached to switching regulator heat-sink

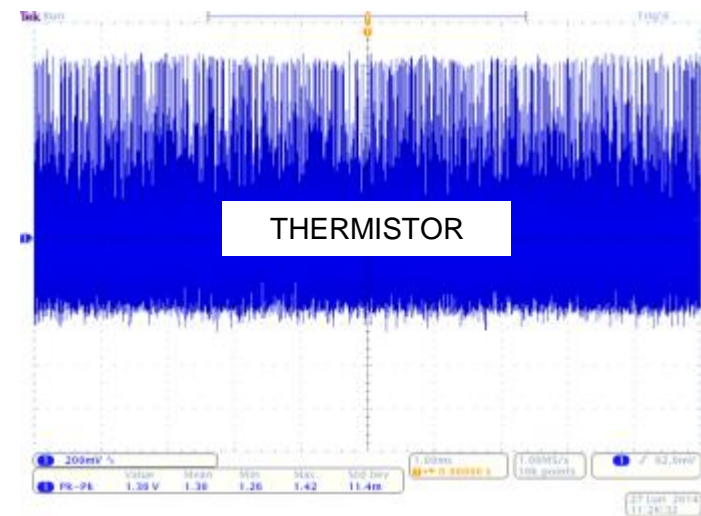
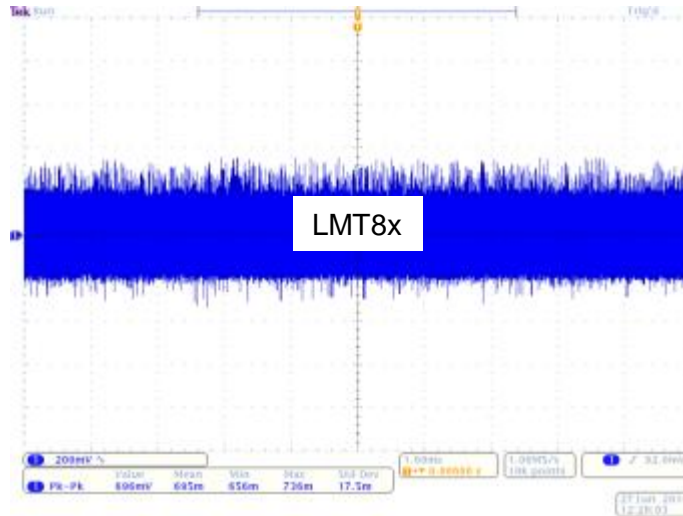

		LMT87	Thermistor
Noise (in mV)		$\pm 25mV$	$\pm 100mV$
Accuracy (in °C)	@ 25°C	$\pm 2^{\circ}C$	$\pm 2^{\circ}C$
	@ 50°C	$\pm 2^{\circ}C$	$\pm 3^{\circ}C$
	@ 100°C	$\pm 2^{\circ}C$	$\pm 14^{\circ}C$

LMT8x – Comparison with Thermistors

LMT8x

- Very linear and accurate across -50°C to 150°C
- No need for external component (integrated Class AB)
- Superior noise immunity
- Very low current 5 μA
- Packaging options SC70, SOT23

Thermistors

- Non-linear and not accurate at high temperature
- Need external component to drive ADC
- Susceptible to noise
- Generally 100s of μA
- Limited package option

Analog Temperature Sensor Solution

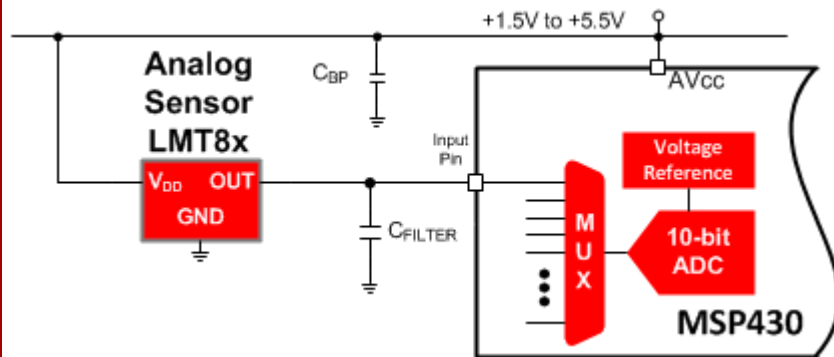

Thermistor Solution

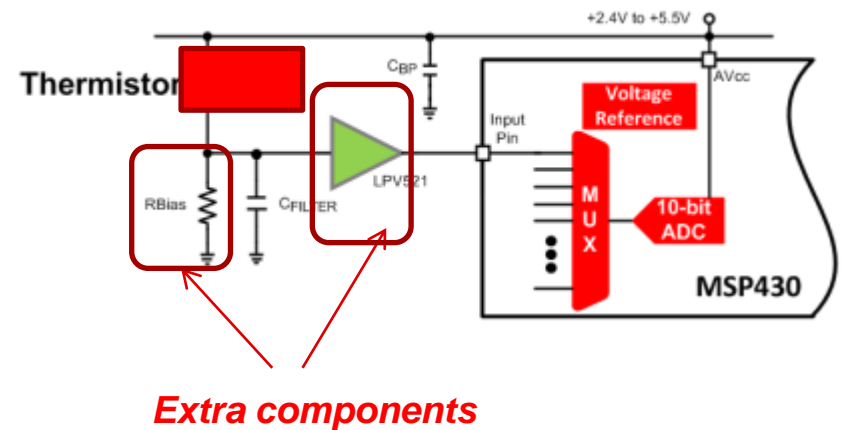

LMT8x – Superior Linearity

- LMT84 - LMT87 provide a linear output over the entire operating range (-50°C to +150°C).
- Thermistor may require software / hardware linearization/compensation for changes in thermal resistance even if temperature range is narrow.

Output Voltage Linearity vs. Temperature

LMT84 Curve

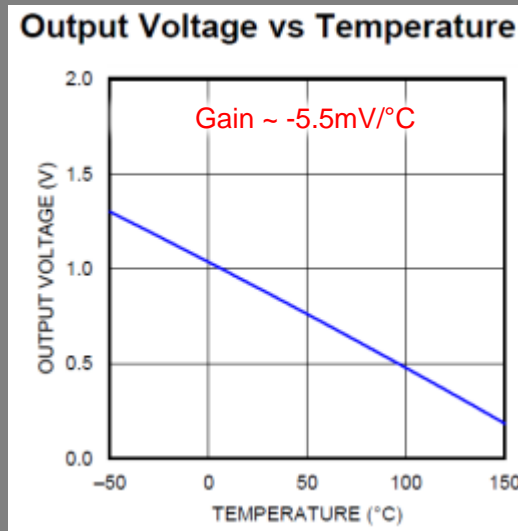

Thermistor Curves

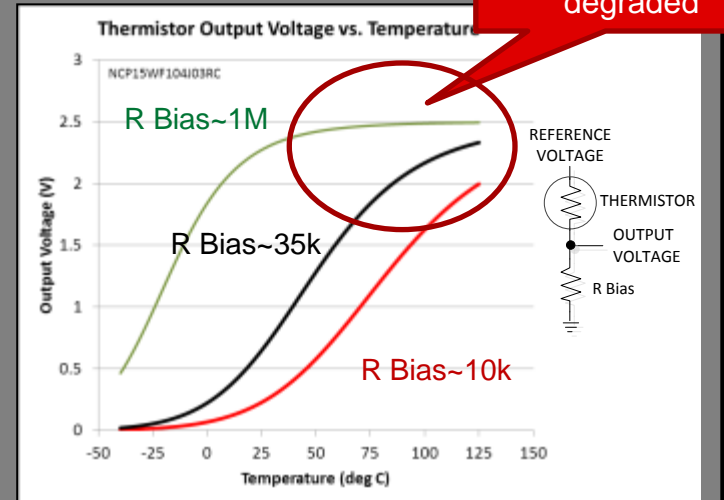

Constant Low Power over Temperature

- LMT84 – LMT87 consume 5.4 μ A supply current across a wide supply voltage & temp range (60x lower power consumption than thermistors)
- Typical thermistors consume 10s to 100s of μ A

Power
Supply
Current
vs.
Temperature

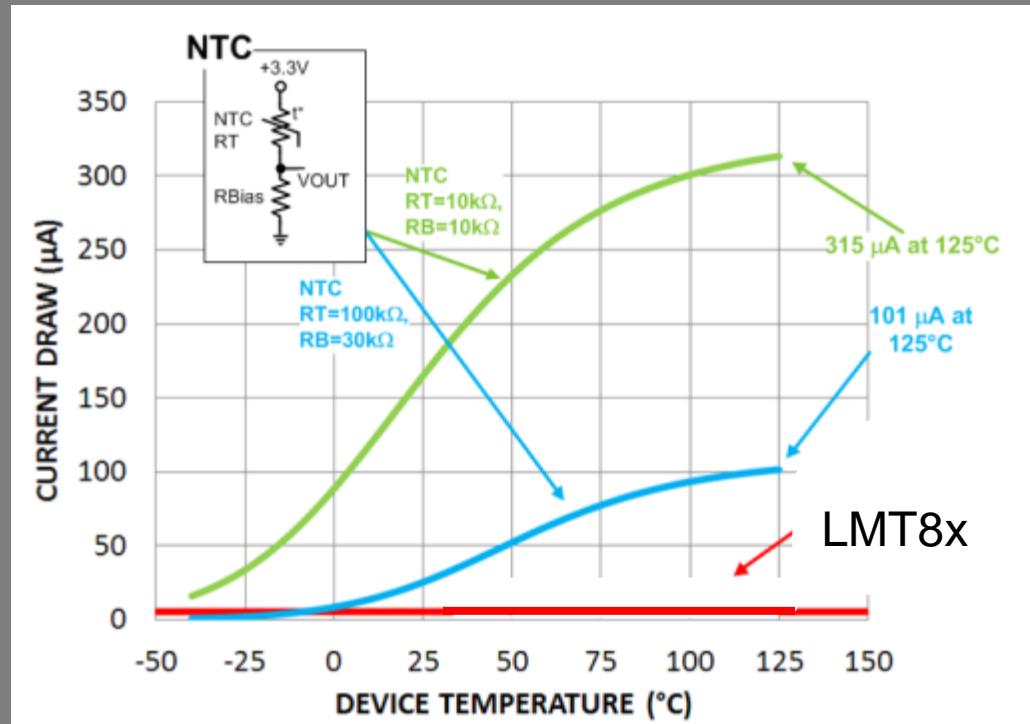

Circuit Simplicity

Simple Connection to MCU/ADC

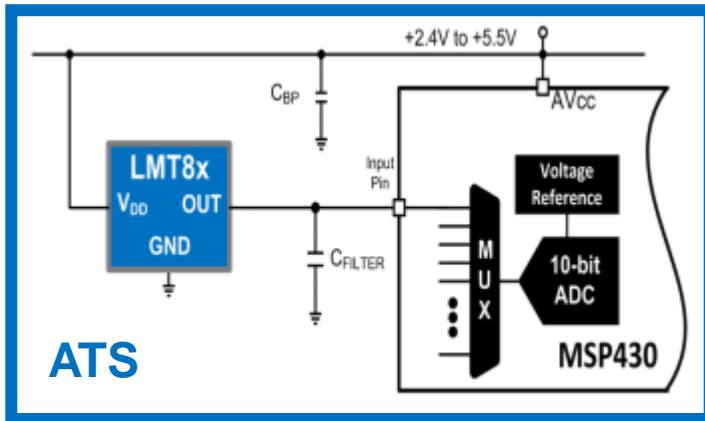

VS.

Additional Resistors Required for Ratio-Metric

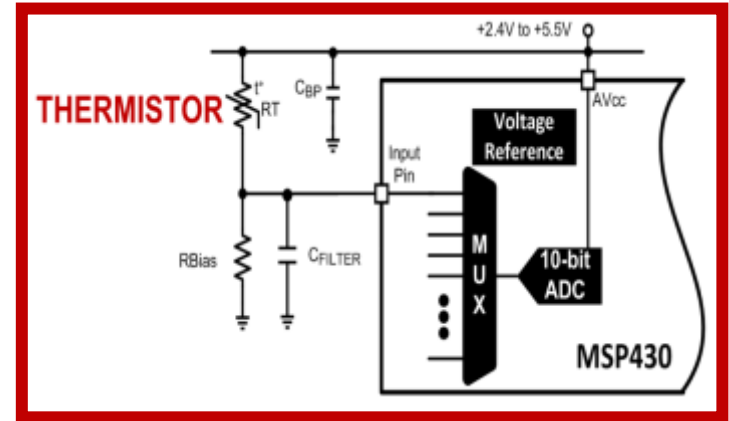

Value Proposition VS Current NTC Solution

Advantages over thermistor solution:

- ✓ Linearity, lower power, no self-heating, accuracy maintained over a wide temp range

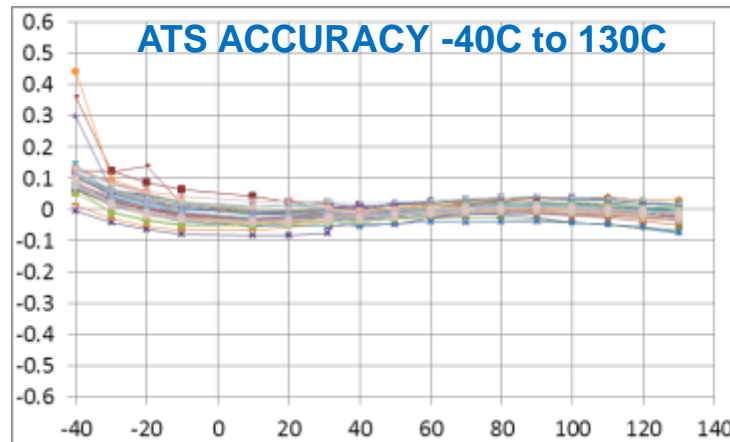
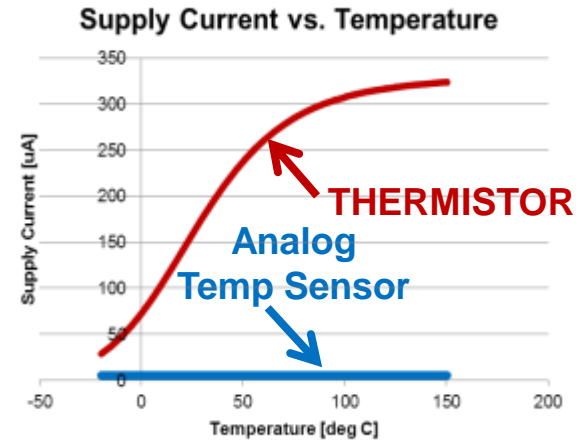
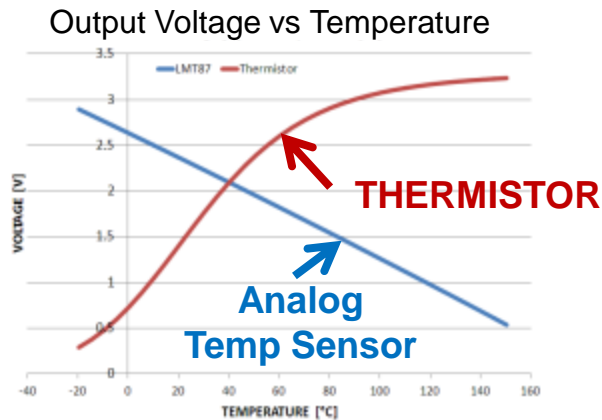

High Accuracy with Low Self Heating

- Accuracy problem: For low noise and minimized effects of parasitic resistances, a low value thermistor (10k Ω or less) should be chosen
- Accuracy trade-off: Low value thermistor introduces more error from self-heating
- Power trade-off: Low value thermistor draws more current and increases average power dissipation
- Solution: Use IC-based sensor for minimal self-heating, low average power consumption across temp range, and consistently high accuracy

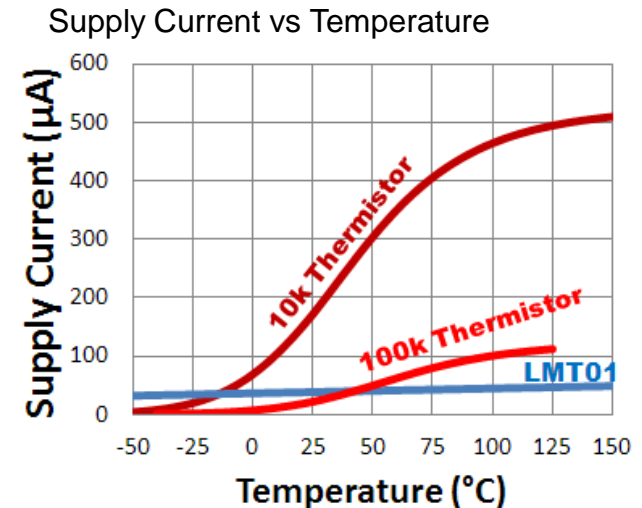
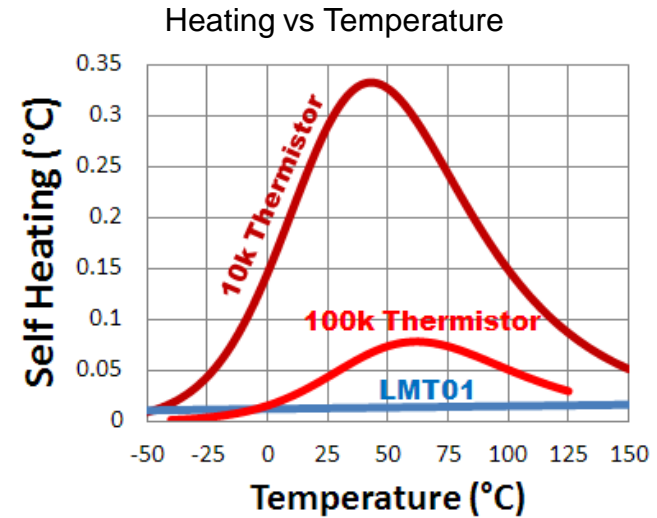

✓ **Minimized Self Heating & Low Average Power**

LMT01: 0.5°C Accurate

2-Pin Digital Temperature Sensor with Pulse Count Interface

Features

- Current pulse-count output interface
- High accuracy
 - ±0.5°C at -20°C to +90°C (max error)
 - ±0.62°C at +90°C to +150°C (max error)
 - ±0.7°C at -50°C to -20°C (max error)
- 100 msec conversion rate
- Wide Supply Range of 2V to 5.5V
 - Quiescent Current: 35µA Max
- 2-pin packages: TO-92S, DFN (in 2016)

Benefits



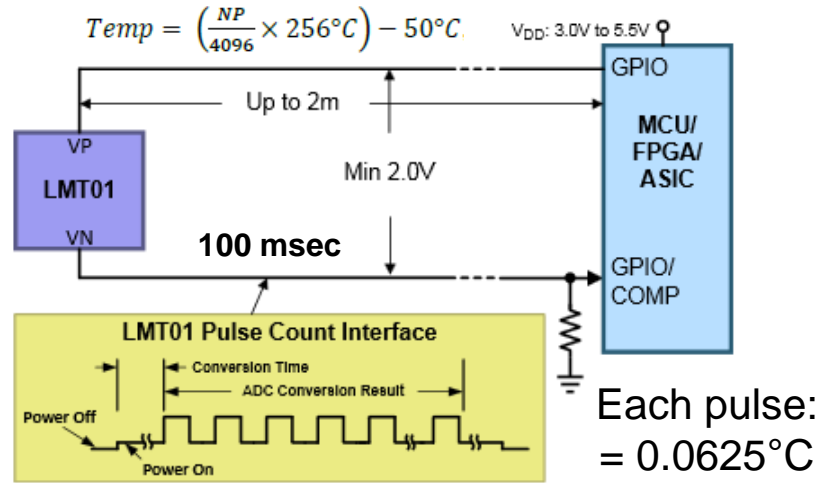
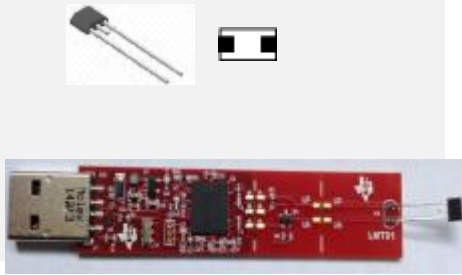

- 2-pin thermistor replacement with digital output
 - Easy-to-use pulse-count output interface with no need for an ADC
 - Noise-free operation, even on long cables
- Consistent, high accuracy over wide temp range replaces multiple precalibrated thermistors
- Low power consumption for battery powered or low voltage devices
- Packages allow for on-board, off-board, and remote mounting
 - Useful for 2-pin wired probe applications

Applications

- Automotive
- Industrial
- White goods
- Power Supplies
- Battery management
- Utilities/Metering



Markets Served by New 2-Pin Temp Sensors

Solutions Enabled with IC-Based Probes	 Automotive	 Battery Packs	 HVAC	 White Goods	 Power Supply
Higher accuracy over temperature	✓ Improved diagnostics	✓ Improved diagnostics & health monitoring	✓ Better system accuracy	✓ Better system reliability	✓ Better system performance
Noisy immunity for accurate readings	✓ Digital outputs	✓ Digital outputs	✓ Digital outputs	✓ Digital outputs	✓ Digital outputs
Reduced error from dirty or corroded connectors	✓ Minimized cable resistance error	✓ Minimized leakage resistance error	✓ Minimized leakage resistance error	✓ Accuracy in humidity	
Simplified electrical isolation	✓ Minimal circuitry			✓ Minimal circuitry	✓ Minimal circuitry
Extended System reliability	✓ High temp accuracy	✓ Improved diagnostics & health monitoring	✓ Lower servicing & handling risk	✓ Lower servicing & handling risk	✓ High temp accuracy

Accuracy vs Temperature

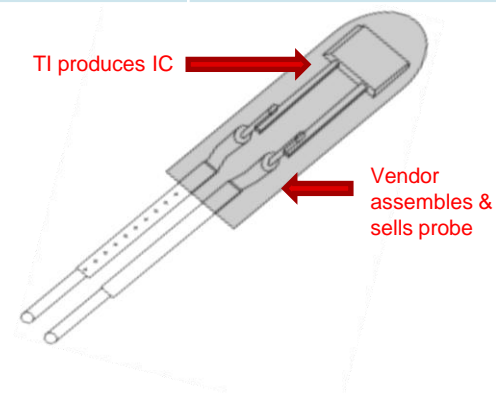
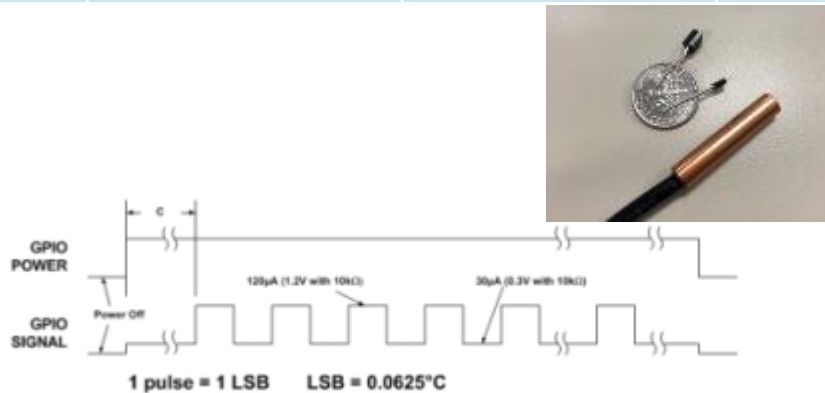
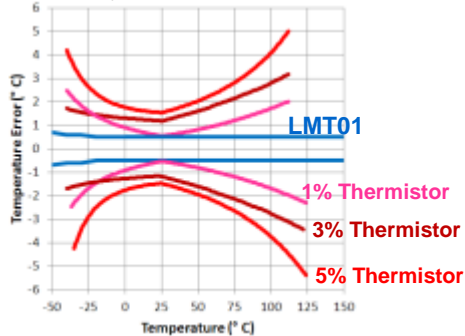

LM57/LM57Q: Resistor Programmable Temperature Switch and Analog Temperature Sensor

Features

- Resistor programmable by the USER to any of the 256-trip temperatures
- Single Temperature Trip Point drives both a Push-pull and an open-drain digital output in one package
- TRIP-TEST pin allows in-system testing
- **AEC-Q100: Grade 1, Grade 0, Extended 175°C**

Accuracy (max)	Commercial (-50°C to 150°C)		AEC-Q100 Grade 1 & Grade 0 (-40°C to 125°C, 150°C)	AEC-Q100 Extended (-50°C to 175°C)
	Version B	Version C		
Package	WSON-8	TSSOP-8 & WSON-8	TSSOP-8	TSSOP-8
Temp Sensor Accuracy	±0.8°C	±1.3°C	±1.3°C	±1.5°C (up to 160°C)
Trip Point Accuracy	±1.5°C	±2.3°C	±2.3°C	±2.5°C (up to 160°C)

Applications

- Industrial
- Appliance
- Instrumentation
- **Automotive**
- **Wide temp down hole or avionics**

Benefits

- One order number for multiple threshold levels, Push-Pull and Open-Drain outputs minimizes inventory requirements
- Threshold level is not dependent on resistor tolerance
- TRIP TEST and VTEMP pins enable in-circuit, post-assembly functional testing
- TRIP TEST pin allows output to latch
- WSON-8 2.5mmx2.5mm; 78% smaller than popular LM56 in SO8 package

New

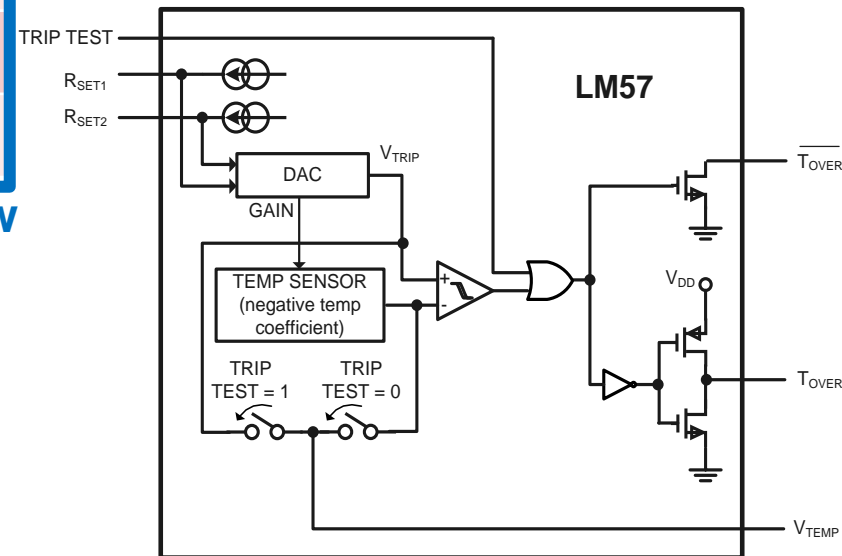

Temperature Sensor Tools and Support

- **EVMs**

- LMT70EVM
- LMT01EVM
- Wired Probe Samples: working with Wired Probe Partners
 - LMT01
 - LMT10

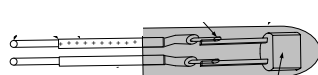

- **TI Designs**

- LMT70 Fast Thermal Response Time in Wearable Devices (TIDA-00452)
- LMT70 Improves Performance in Body Temperature Monitors using NFC (June 2015)
- Isolated Temperature Sensing with LMT01 (June 2015)

- **Applications Notes**

- Thermal response time considerations for Temperature Sensors (LMT8x, LMT70)
- Optimizing Accuracy of the LMT70 with MSP430 by utilizing calibration coefficients
- Calibration and Curve Fitting Techniques for Ultra High Accuracy (LMT70)
- Why Corrosion Degrades Accuracy for Thermistors but not the LMT01 (Water Heater Application)

- **Temperature Sensing E2E forum**

- http://e2e.ti.com/support/sensor/temperature_sensors/

- **Learn about all TI sensing solutions**

- www.ti.com/sensing



Inductive Sensor Solutions

LDC Enables Inductive Sensing

Inductive sensing

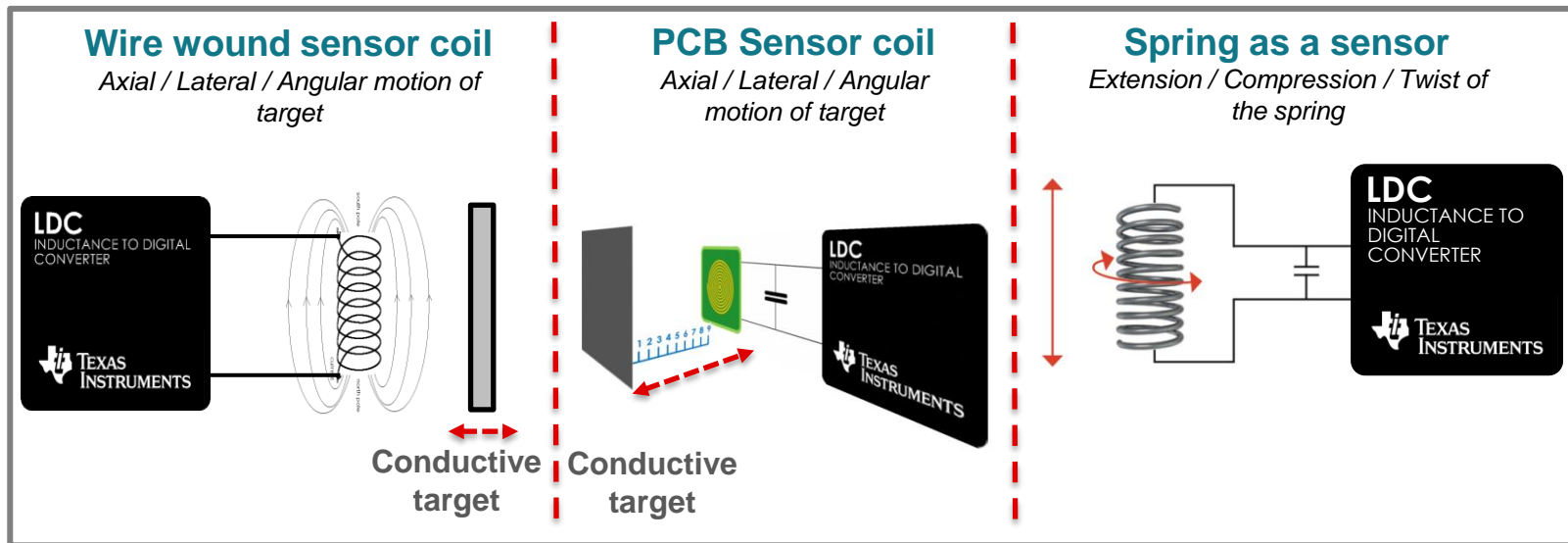

Benefits

Advantages of Inductive Sensing:

- ⊙ Does not require magnets
- ⊙ Reliable by virtue of being contactless
- ⊙ Insensitive to environmental contaminants (dust, dirt, etc.)
- ⊙ Sub-micron resolution
- ⊙ Sensor is low-cost
- ⊙ Electronics can be located remotely from the sensor

Application Use Cases

Axial distance Measurement

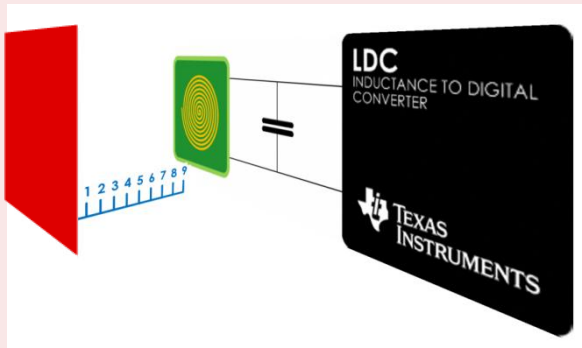

Linear Position Sensing

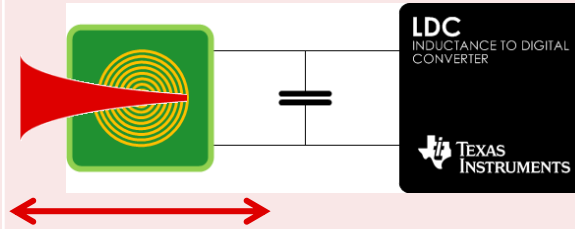

Angular Position Sensing

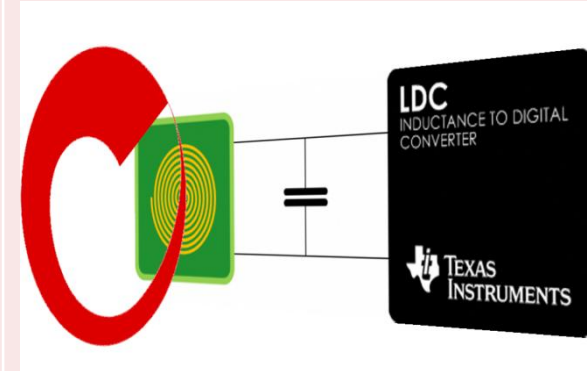

Event Counting

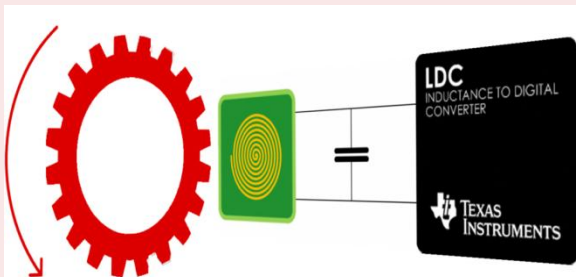

Spring Measurement

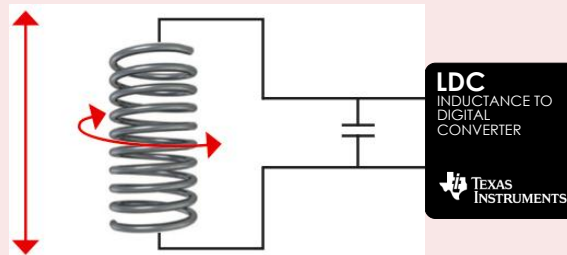

Metal Identification

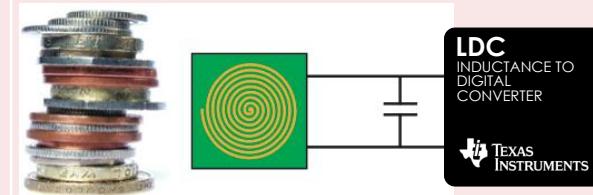

LDC Applications

Absolute and incremental rotational position and motion sensing

CONDUCTIVE
TARGET

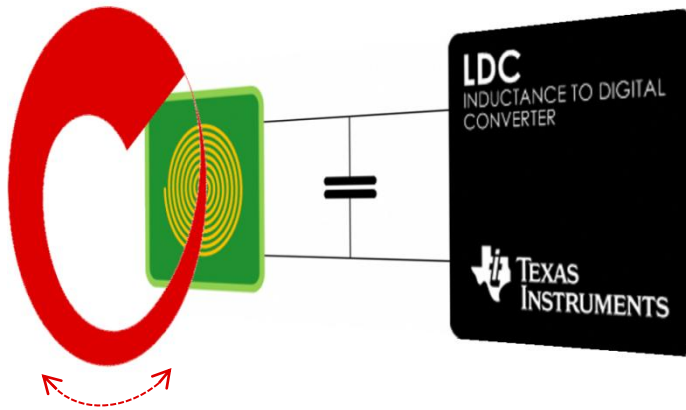

**Sense the amount of
metal covering coil**

Uses

- Rotational position, motor encoding, knobs

Target End Equipment

- Industrial/white goods: knobs, industrial HMI, factory automation, valve position, inductive cooktop, washers, dryers
- Automotive: pedal position, steering position, throttle position, infotainment
- Consumer: printers, cameras, DJ consoles, audio systems

System Benefits

- Remote sensing possible with very low cost sensor
- Well matched multi-channel solution for environmental/vibration compensation
- Robust solution: insensitive to harsh environments (oil, dirt, dust, moisture)

Demos

LDC Automotive Knob devices

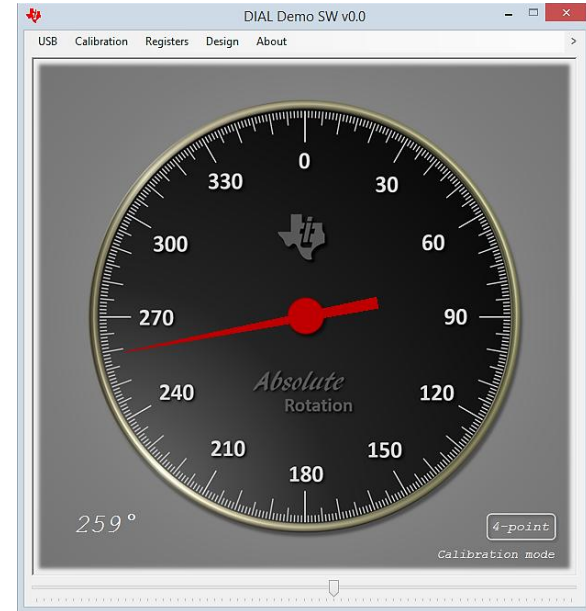
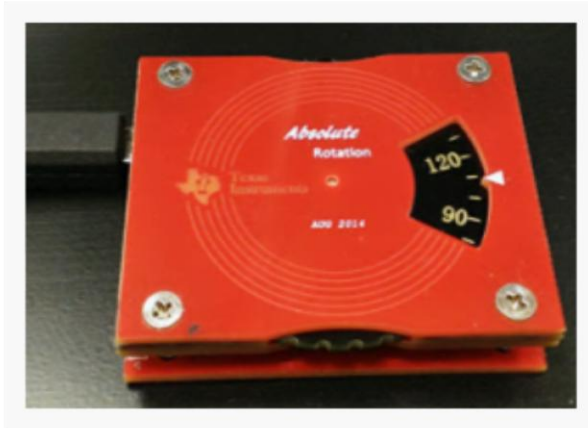

Benefits

- ◎ Standard FR4 PCB process
- ◎ Off-the-shelf parts
- ◎ No look-up table is required
- ◎ Great stability and consistency
- ◎ Allows simple target metal design rule (rotational or linear)
- ◎ Can be used for rotation and linear sensing
- ◎ 3 calibration methods suiting different applications

Absolute encoder technology

Optical Target

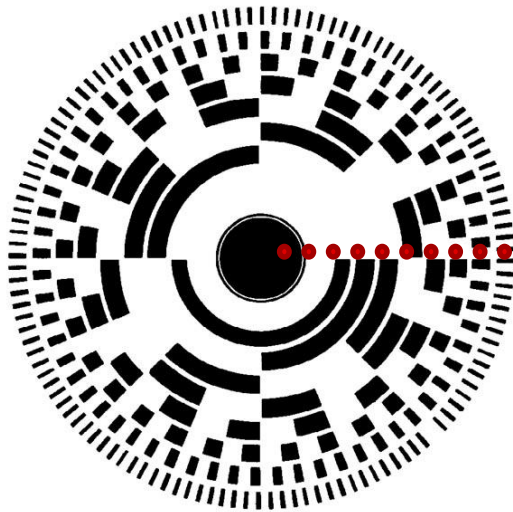

10 optical sensors
→ 0.3° resolution

Inductive Target

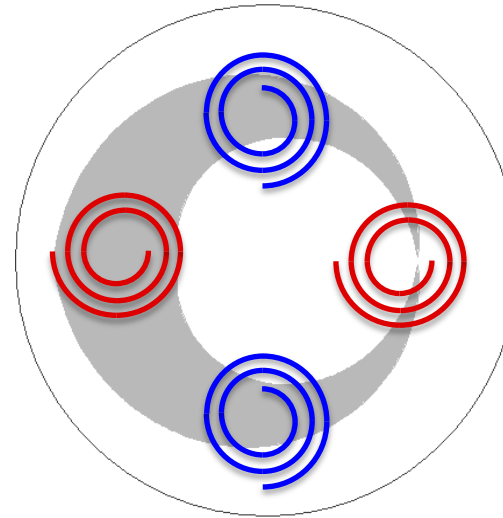

4 sensor coils with one IC
→ 0.1° resolution

Inductive absolute encoder is a low cost solution to get high resolution and accuracy

Mechanical construction

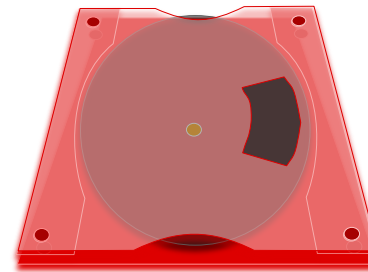
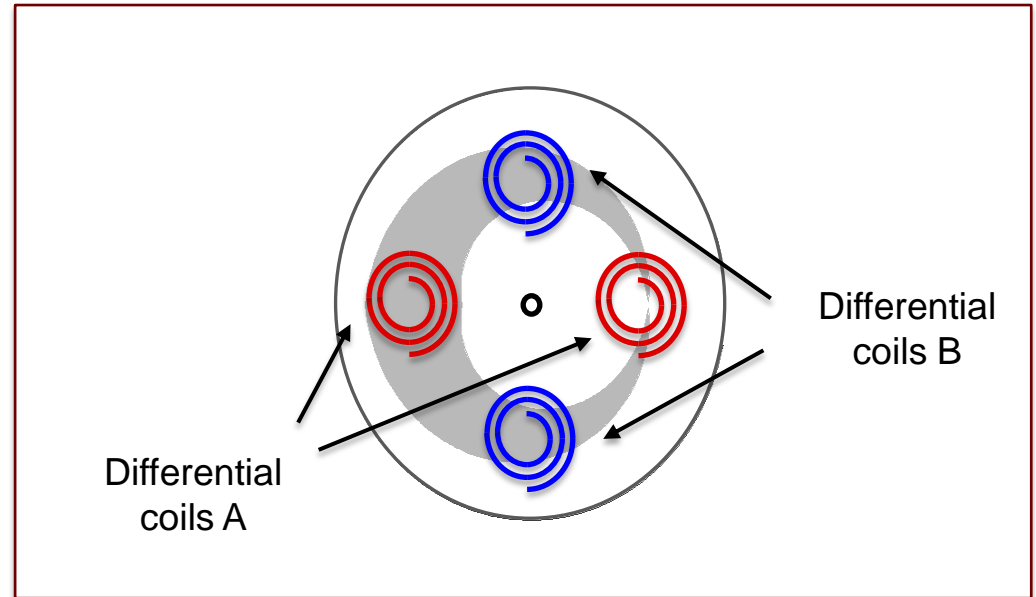
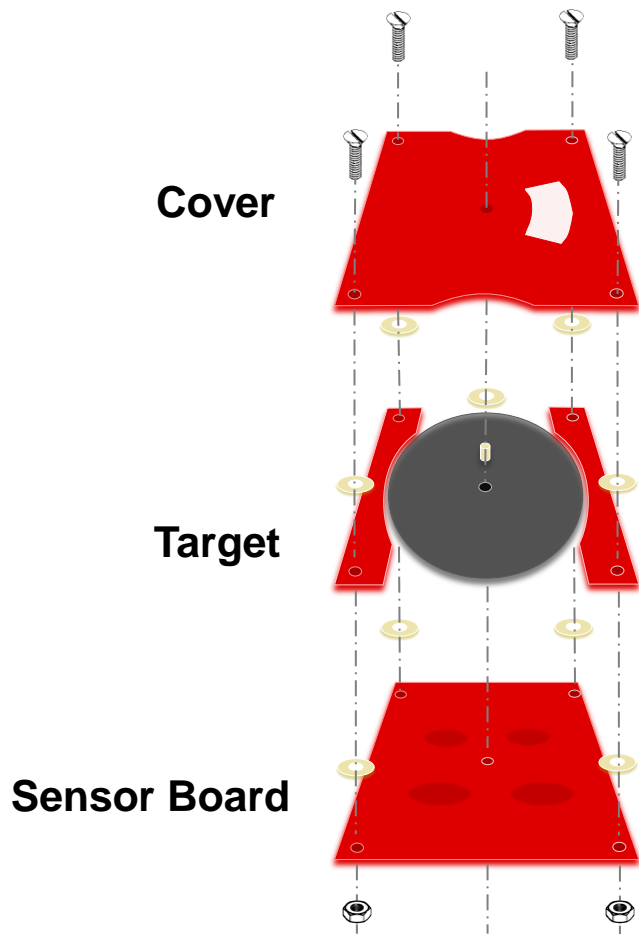

Inductive Sensing Solutions from TI

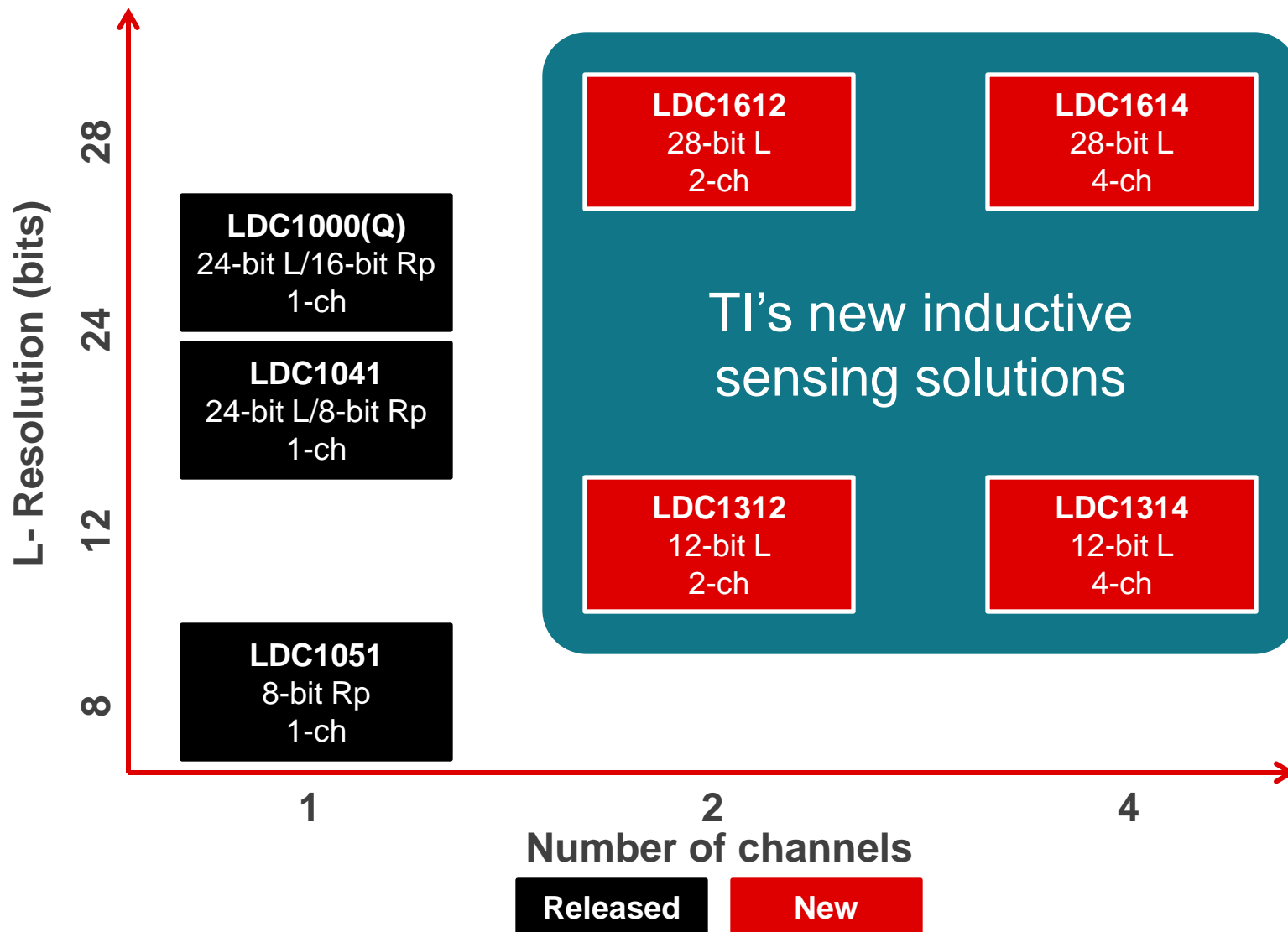

LDC1312/4

2-/4-ch, 3.3-V, 12-bit LDCs for Inductive Sensing

Features

- Multiple channels:
 - 2-ch: LDC1312, 4-ch: LDC1314
- Well matched channels w/ 13.3 ksps max. sampling rate
- Sensor frequency range: 1kHz to 10 MHz
- Power consumption:
 - Active: 540uA/ch (LDC1314)
 - Sleep: 35uA, Shutdown: 200nA
- Package
 - LDC1312: 12-pin WSON
 - LDC1314: 16-pin WQFN

Applications

- Knobs in consumer, appliance, & automotive
- Incremental linear and rotational encoders
- Buttons in home electronics, wearables, & factories
- Keypads, HMI, and POS in factories & appliances
- Slider buttons in consumer
- Metal detection in industrial & consumer
- Flow meters in consumer and appliances

Benefits

- Up to four channels enables multiple sensors in minimum system size, cost, and power
- Well-matched channels allow for easy compensation of environmental changes and aging
- Easy-to-use: sensor just needs to be within 1kHz and 10 MHz, simplifying and accelerating prototyping
- Large sensor frequency range supports very small PCB coils, supporting space-constrained applications

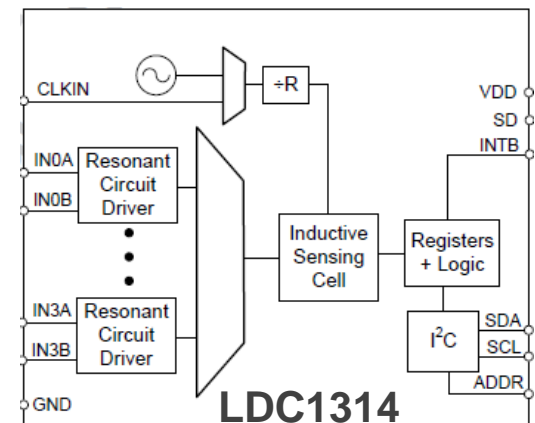

LDC1612/4

2-/4-ch, 3.3-V, 28-bit LDCs for Inductive Sensing

Features

- Multiple channels
 - 2-ch: LDC1612, 4-ch: LDC1614
- Well matched channels with 4.08 ksps max sampling rate
- Resolution: 28 bits
- Sensor frequency range: 1kHz to 10 MHz
- Power consumption:
 - Active: 540uA/ch (LDC1614)
 - Sleep: 35uA, Shutdown: 200nA
- Package
 - LDC1612: 12-pin WSON
 - LDC1614: 16-pin WQFN

Applications

- Knobs in consumer, appliance, & automotive
- Incremental linear and rotational encoders
- Buttons in home electronics, wearables, & factories
- Keypads, HMI, and POS in factories & appliances
- Slider buttons in consumer
- Metal detection in industrial & consumer
- Flow meters in consumer and appliances

Benefits

- Up to four channels enables multiple sensors in minimum system size, cost, and power
- Well-matched channels allow for easy compensation of environmental changes and aging
- High resolution enables better end-system performance and efficiency and extended sensing range
- Easy-to-use: sensor just needs to be within 1kHz and 10 MHz, simplifying and accelerating prototyping
- Large sensor frequency range supports very small PCB coils, supporting space-constrained applications

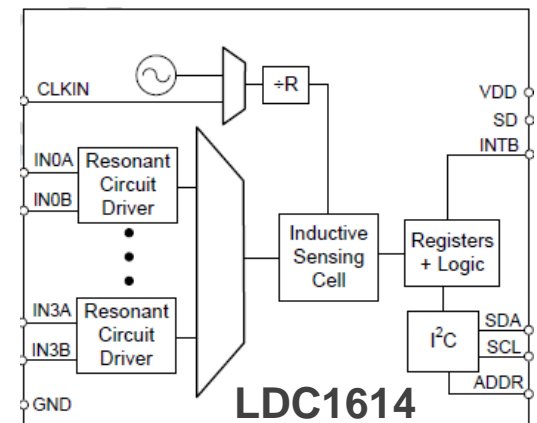

LDC131x/161x EVM

Explore the possibilities

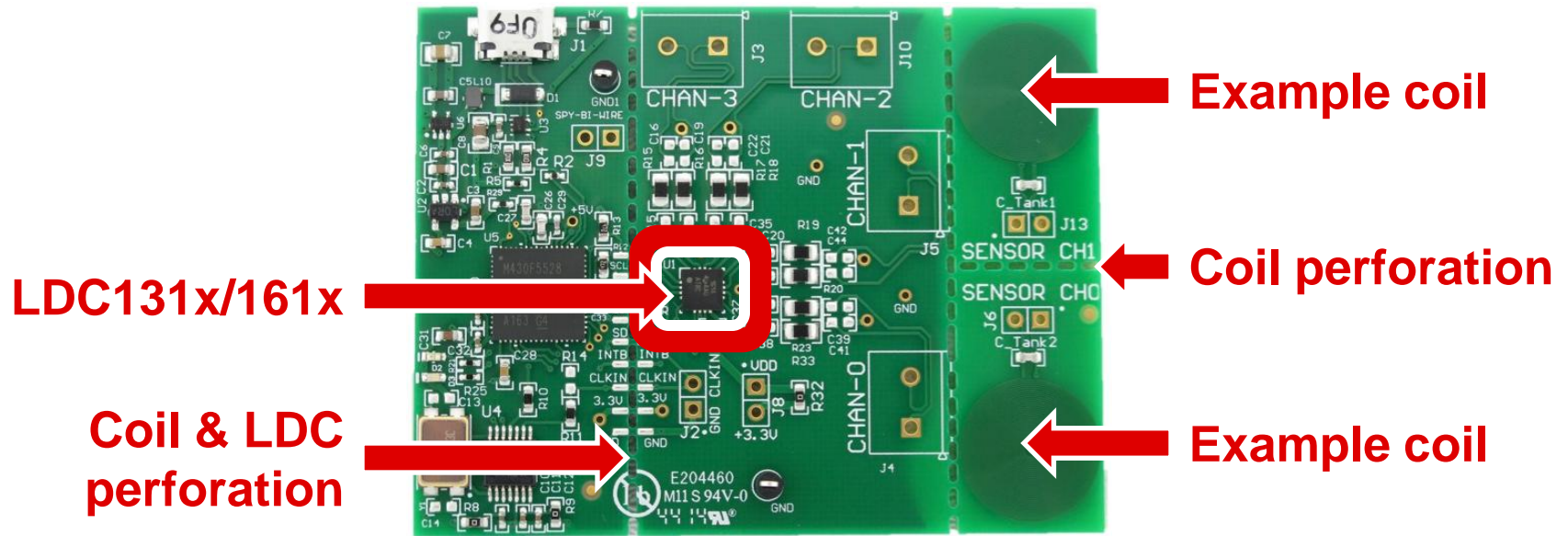

- EVM and GUI provide complete prototyping and evaluation platform
- USB interface allows control and evaluation of LDC131x/161x with GUI
- Includes two example PCB coil sensors
- Coil and LDC board sections can be removed
 - Coils can be removed to **allow prototyping with other coils, springs or inductors**
 - **Interface** with other MCUs via **I2C**

LDC Switch

Inductive switches

Use case 1: Fixed inductance with LDC8051

- Inputs – 3 (2 sensing coils)
- VDD – 1
- GND – 1
- Output – 1
- TADJ – Threshold Adjust pin

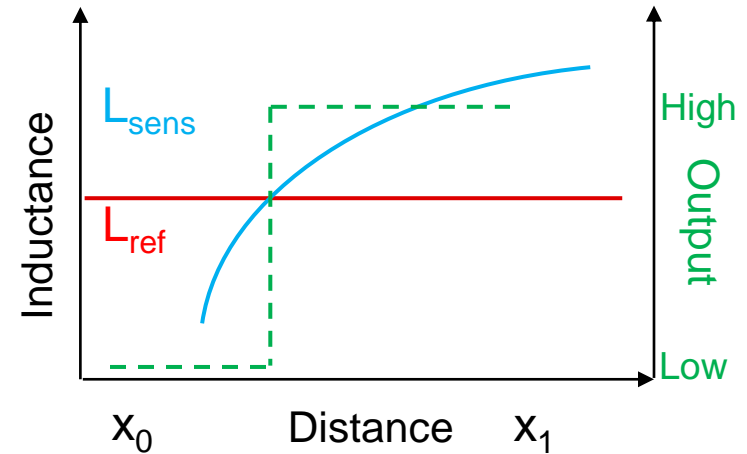
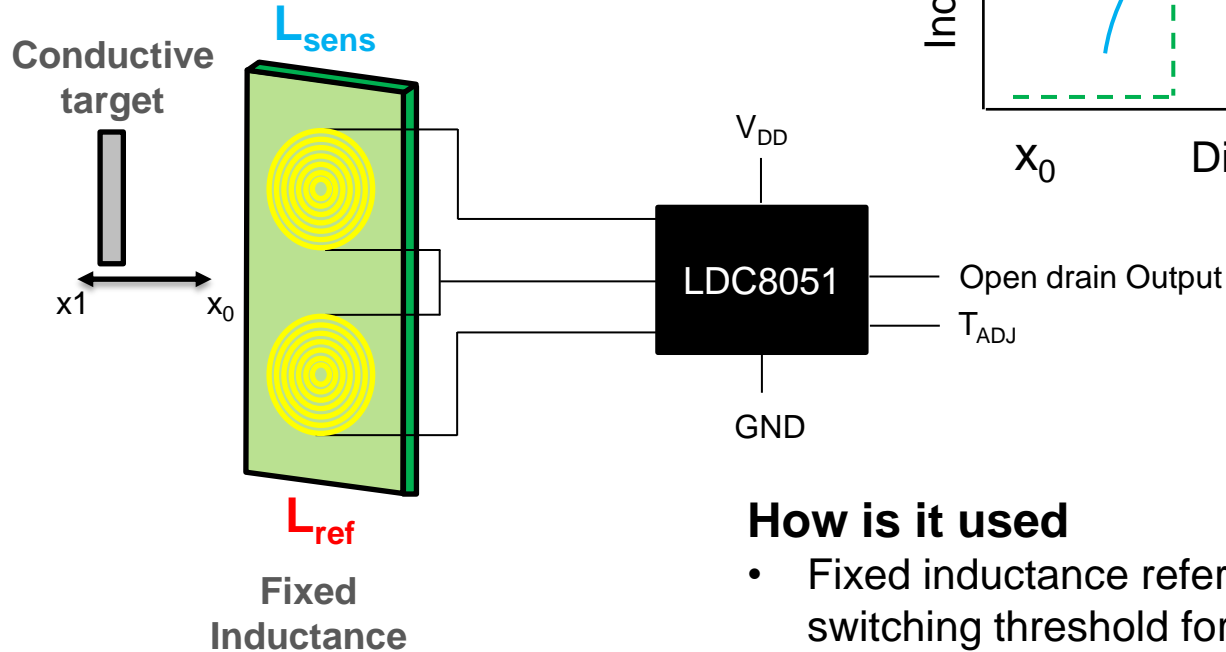

How is it used

- Fixed inductance reference coil serves as switching threshold for the sensing coil
- Once the moving target crosses the reference inductance, the LDC8051 switches

Inductive switches

Use case 2: Linear switching with equal coils with LDC8051

- Inputs – 3 (2 sensing coils)
- VDD – 1
- GND – 1
- Output – 1
- TADJ – Threshold Adjust pin



Conductive target

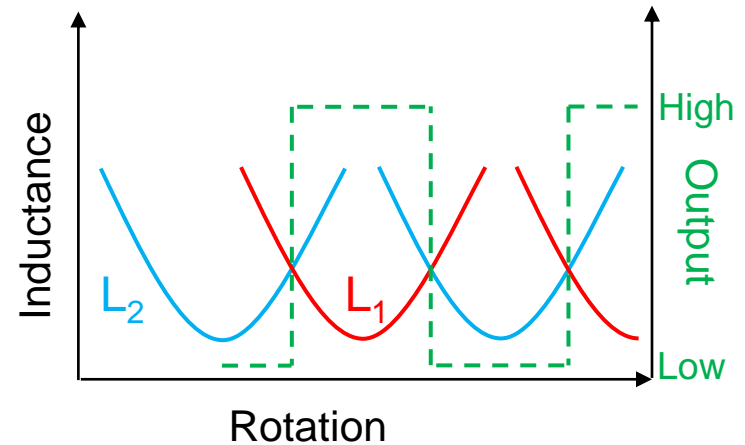
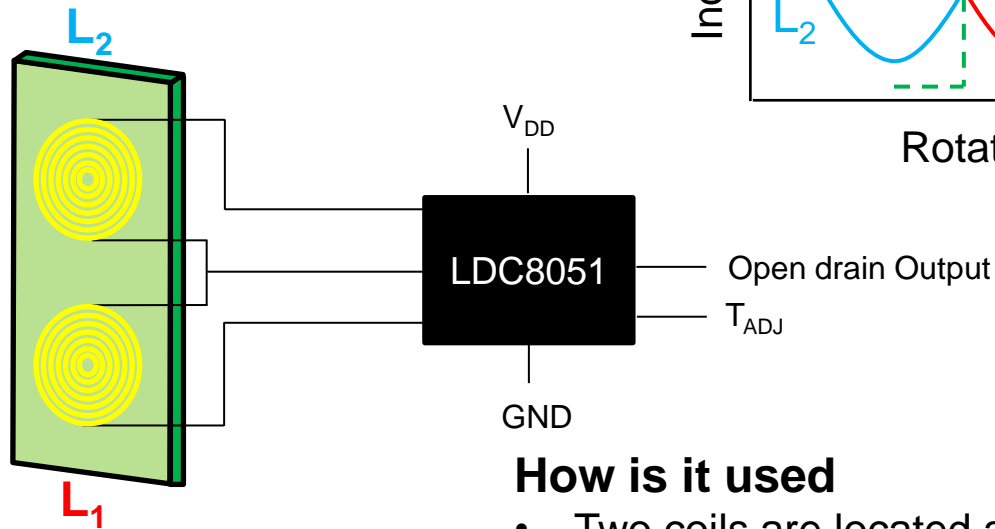

How is it used

- Two coils are located adjacent to each other on the same PCB plane
- Once the moving target (in this case a blade) passes one coil and starts to cross the second coil, the inductances match at some point and hence LDC8051 will switch

Inductive switches

Use case 3: Linear switching with equal coils with LDC8051

- Inputs – 3 (2 sensing coils)
- VDD – 1
- GND – 1
- Output – 1
- TADJ – Threshold Adjust pin

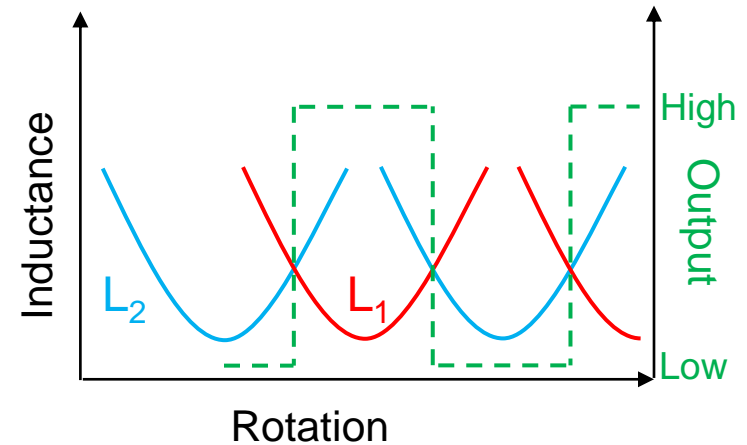
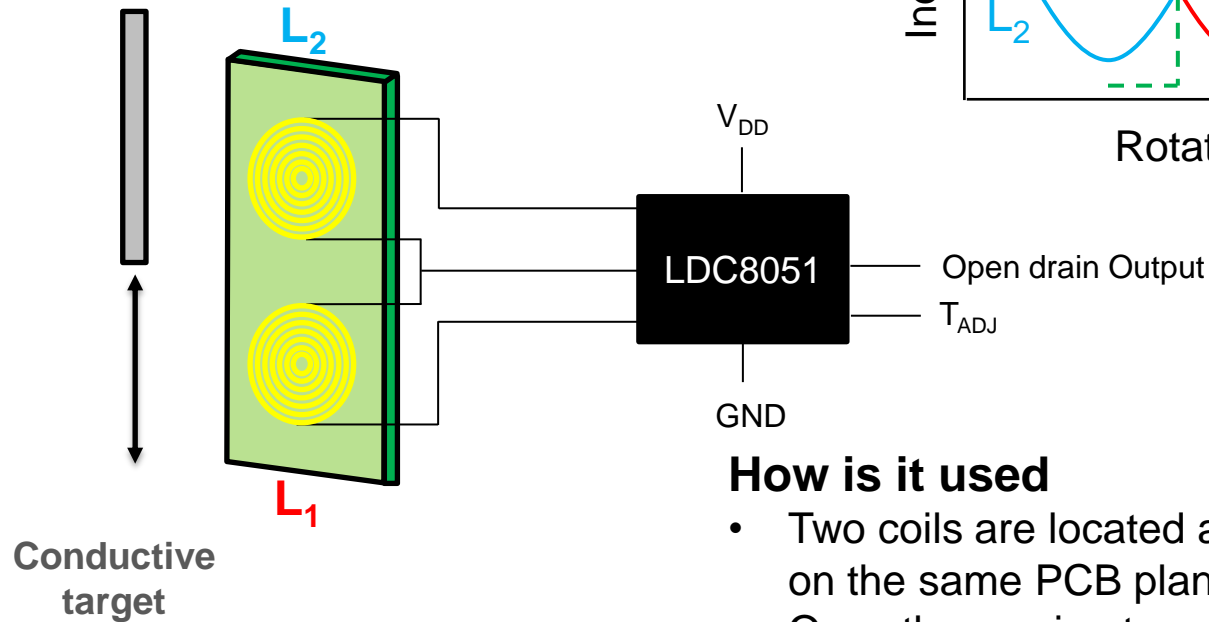

How is it used

- Two coils are located adjacent to each other on the same PCB plane
- Once the moving target (in this case slider) passes one coil and starts to cross the second coil, the inductances match at some point and hence LDC8051 will switch

Inductive switches

Use case 4: Compact solution with LDC8051

- Inputs – 3 (2 sensing coils)
- VDD – 1
- GND – 1
- Output – 1
- TADJ – Threshold Adjust pin

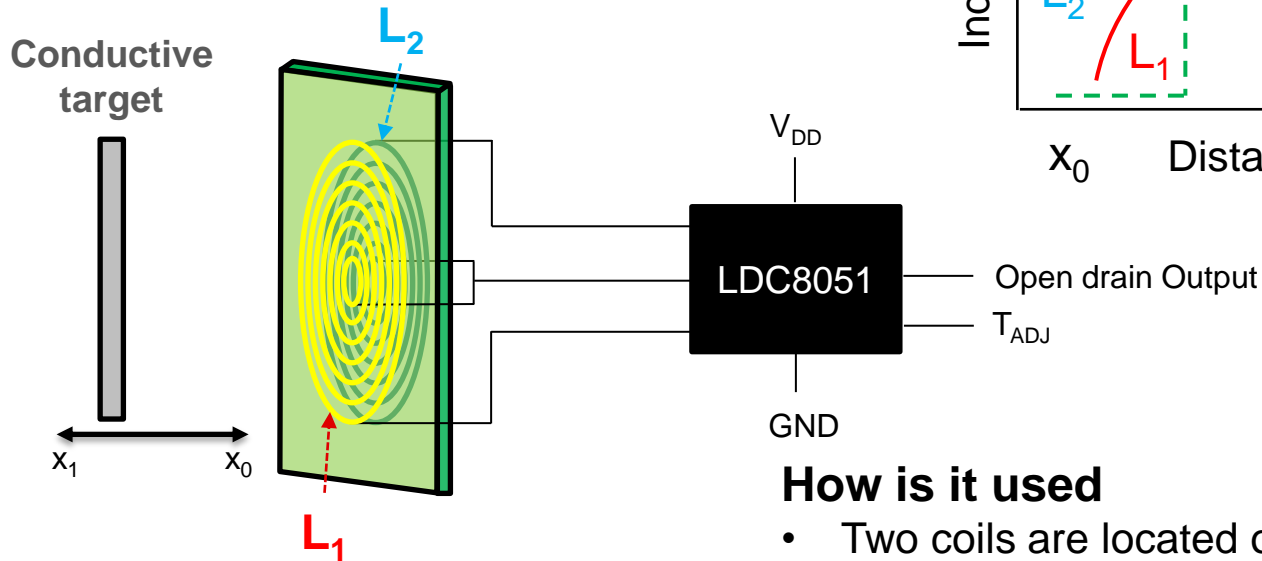
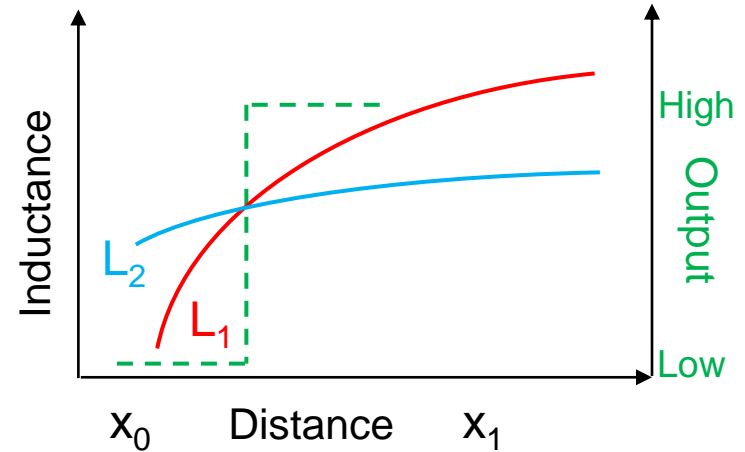

How is it used

- Two coils are located on different PCB planes
- Once the moving target passes one coil and starts to cross the second coil, the inductance matches and the LDC8051 will switch

Ultrasonic Sensor

Ultrasonic Overview

Single Transducer (xDc) Time-of-Flight (TOF) Theory

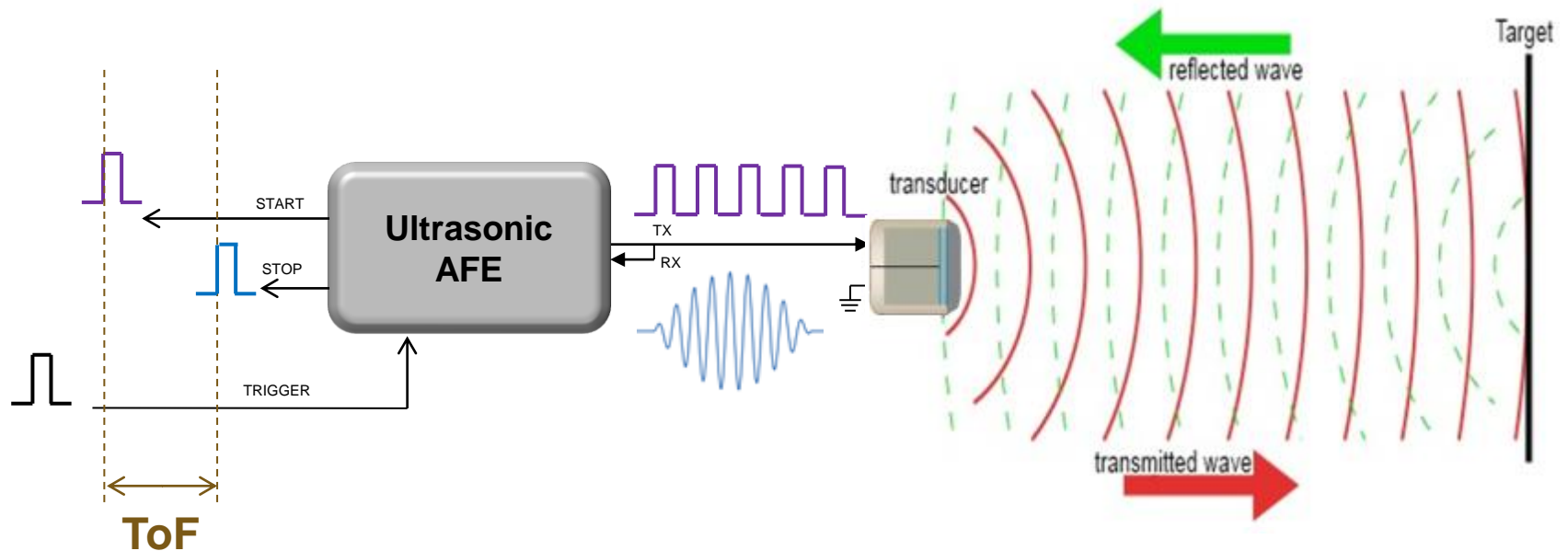

- The xDc is excited by **voltage pulses** from Tx section of the TDC1000
- The xDc transmits an **ultrasonic energy** into the medium (air, water, gas, etc)
- When the **wave** hits the target, it is reflected back.
- The wave creates an **echo**, which is received by the RX chain
- **ToF** is measured between the transmitted wave and the reflected wave.
- $\text{ToF} = \frac{\text{distance}}{\text{speed of sound in medium}} \propto \text{distance, concentration, type of fluid, level of fluid, etc}$

Ultrasonic Solutions from TI

PSP-ISC

TDC1000/Q1

Short Range High Precision

- Key Applications
 - Ultrasonic flow measurement
 - Liquid level and concentration detection
 - Presence/distance detection (0.5m to 2m, 1mm resolution)
- Measurement Approach
 - Zero cross detection & Time to digital converter (TDC)
- MCU
 - Requires external MCU

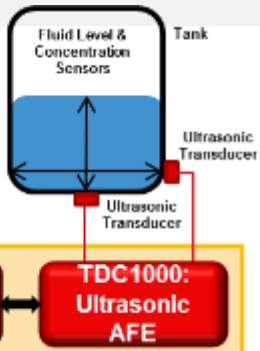

MSP430

MSP430FR9(x)

Integrated AFE Solution

- Key Applications
 - Ultrasonic flow measurement
- Measurement Approach
 - ADC based cross correlation for ΔT measurements
- AFE
 - Integrated AFE. No external components required

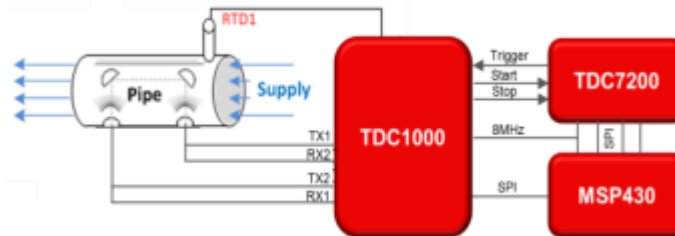

MSA

PGA450-Q1

Long Range Low Precision

- Key Applications
 - Automotive Ultrasonic Part Assist
 - Blind spot detection
 - Presence, Distance, Proximity Detection (10cm - 6m, 1cm resolution)
- Measurement Approach
 - DSP Time of Flight Envelope Detection
- MCU
 - Integrated 8-bit 8051

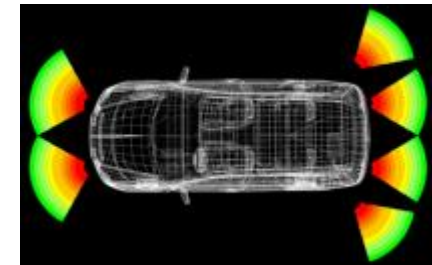

Intro to Ultrasonic Sensing Applications & Benefits

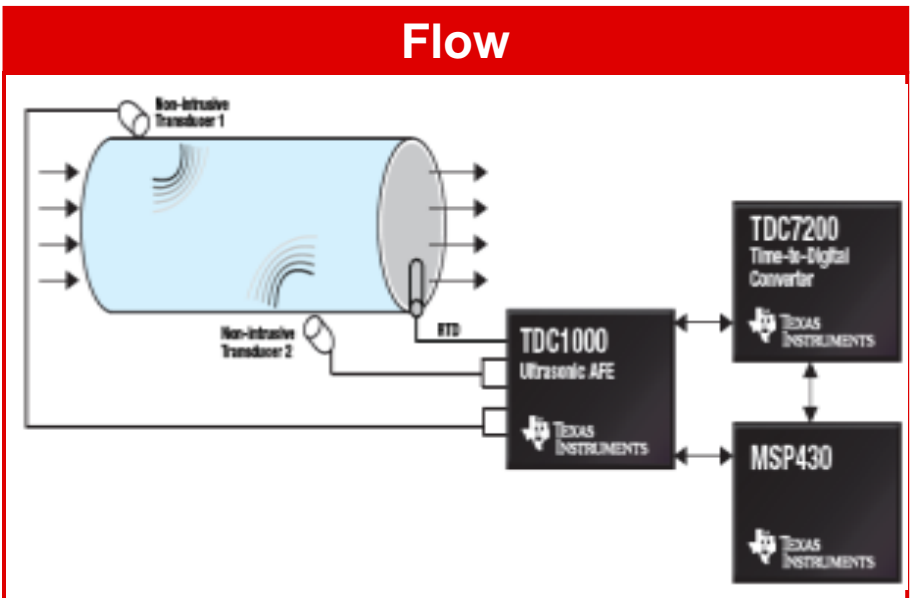
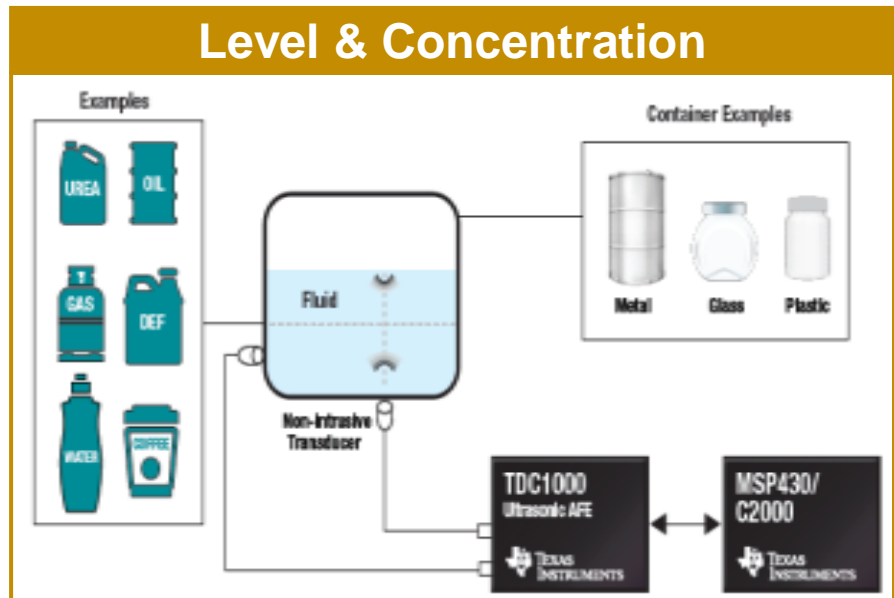

Ultrasonic Sensing Advantages

Features	Benefits
High accuracy	Detect zero flow or low level fluids
Low power	Longer battery life
Non-intrusive sensor	Simple to design, no maintenance or contact with corrosive materials
Use with varying tank sizes and materials	Wide range of applications, design reusability

Automotive Fluid Level & Identification

Ultrasonic Sensing Applications

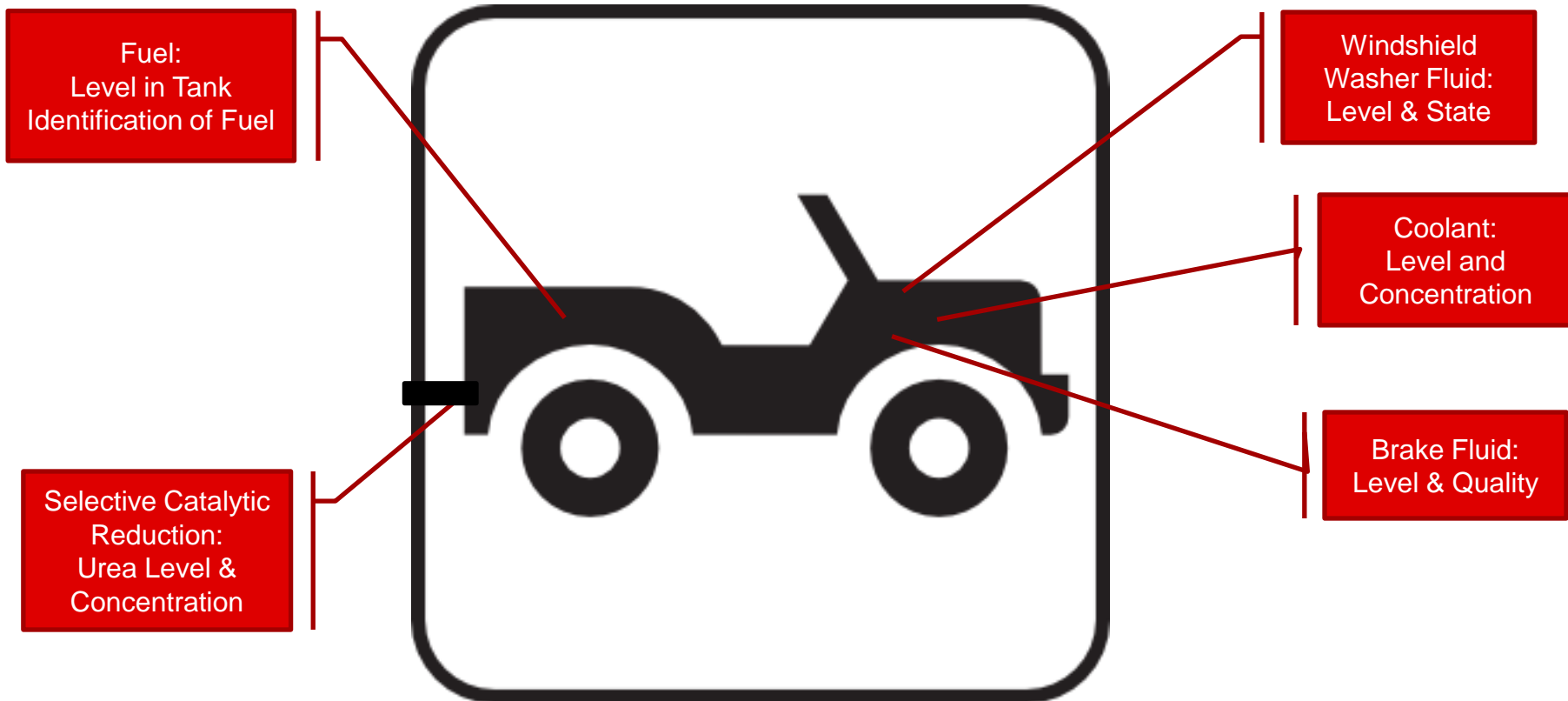

Proximity Ultrasonic Solutions

TDC1000/Q1

- **0.1 - 200cm, 1mm resolution**
- 2.7 - 5.5V
- Freq. Range: 30kHz – 4MHz
- Driver: 0.2 W_{MAX}
- Receiver: 41dB Gain
- Fixed Function State Machine
- Start/Stop Pulse Data Output

PGA450-Q1

- **10 - 600cm, 1cm resolution**
- 7 -18V ; I_q = 5mA
- 40 V Load Dump Protection
- Freq Range: 40kHz – 70kHz
- Driver: 12 W_{MAX}
- Receiver: 64dB Gain
- Programmable 8051 MCU
- LIN/UART/IO Data Interface

PGA460-Q1

- **10 - 800cm, 1cm resolution**
- 5 -18V ; I_q <1mA
- 40 V Load Dump Protection
- Freq Range: 30kHz – 80kHz
- Driver: 6 W_{MAX}
- Receiver: 90dB Gain
- Fixed Function State Machine
- LIN/Time Data Interface

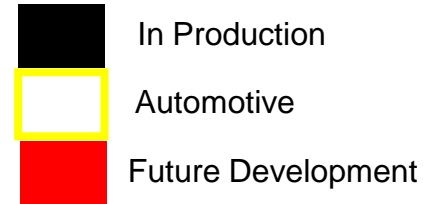

Detection
Distance

TDC1000 and TDC1000-Q1

Ultrasonic Analog-Front-End (AFE)

Features

- STOP Cycle-to-Cycle Jitter: 50 ps-rms
- Operating current: 1.8 uA (2 SPS)
- Programmable Features:
 - TX1/TX2 Excitation: 31.25 kHz to 4 MHz, up to 31 pulses
 - Low-noise and programmable gain amplifiers
 - Programmable threshold comparator for echo qualification
- Available with complete system reference designs ([TIDA-00322](#) and TIDA-ULTRAOSNIC-FLOW-TDC)
- Other Key Specs:
 - Measurement range: up to 8ms
 - RTD-to-RTD matching accuracy 0.05°C
- Available in AEC-Q100

Applications

- Fluid level
- Fluid identification / concentration
- Flow metering: water, gas, heat
- Distance / proximity

Benefits

- High accuracy enables zero flow detection for accurate meter billing
- Low power consumption saves battery replacement costs due to longer battery life
- Programmability to adapt to multiple applications and varying tank or pipe sizes
- TI provides the entire system design: AFE, TDC, MCU, wireless, power, & source code
- TDC1000-Q1 is the only automotive qualified ultrasonic AFE on the market

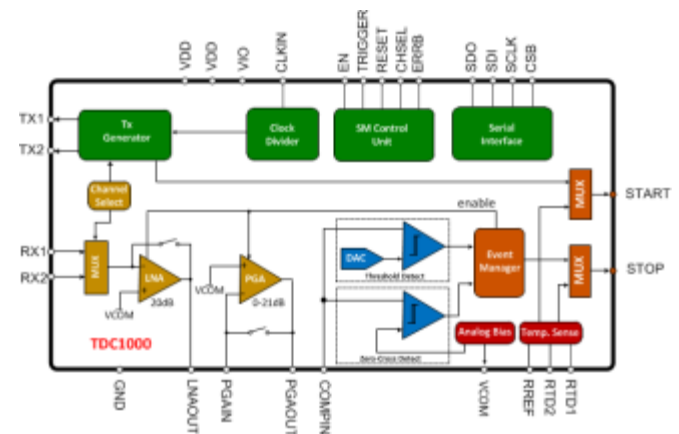

Mechanical and Magnetic. Vs Ultrasonic Sensing for Level Measurements

	Ultrasonic Sensing	Magnetic/Mechanical Float Based Meters
Accuracy	<1mm accuracy	Typically accuracy +/-15% to 20%
Installation	Can be mounted inside/outside of tank - non invasive mounting	Mounted with direct contact with fluids i.e. invasive thus subject to corrosion
Maintenance	Easier to maintain with non invasive mounting. Can be easily debugged if issues are found	Difficult to maintain because mechanical unit is inside the tank; not easy to debug source of problem
Scalability	Highly scalable design to adapt to multiple tank sizes by changing register settings	Needs complete mechanical redesign of tanks
Operating Temperature	-40C to +125C	-40C to >150C
System Cost	*\$5-\$8 *depending on design	\$5-\$10 * depending on size and construction of the mechanical sensor



Tools to Win – TDC1000-7200 Design Resources

Webench, EVMs, Reference Designs, App Notes, Demo Kits, Videos

EVMs

TDC1000-TDC7200EVM and Software



- Evaluate TDC1000-Q1 ultrasonic analog-front-end
- User friendly TDC1000-C2000 GUI interface
- On-board C2000-TMS320F28035 PAG Microcontroller to process data
- Powered by USB

TDC1000-C2000EVM and Software



- User friendly GUI interface
- On-board MSP430F5528 to process data
- Connectors for two ultrasonic transducers, and connectors for two RT sensors.
- Powered by USB

TDC1000-GASEVM + TDC1000-BSTEVM

Webench TDC Widget

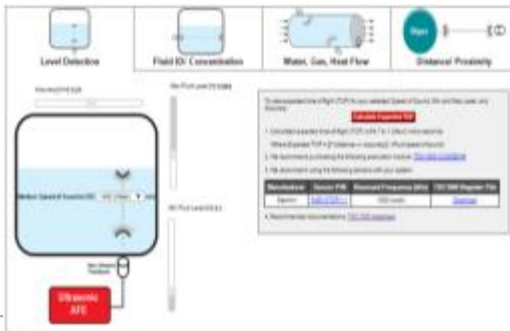

- Easy to use online tool
- Calculate Expected TOF
- EVM and Sensors Recommendation
- Download register files for appropriate application

TI Designs

TIDA-00322



- Dual Channel Analog-front-end for ultrasonic sensing
- High voltage circuit to drive the transducer with 30V to penetrate deeper tanks
- Input voltage range of 6V to 40V with reverse battery protection
- Automotive qualified Bill of Material

Ultrasonic TDC Flowmeter Reference Design

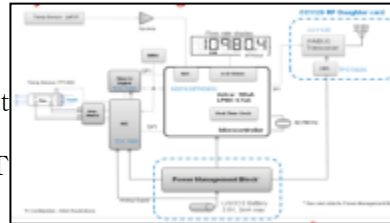

- 320 Segment low-power 8-mux LCD
- Smart power control with sleep current $< 1\mu\text{A}$
- LSB: 52ps and Standard Deviation 42 ps

Application Notes

- Basics of Ultrasonic Sensing with TDC1000
- Selecting and Mounting the Transducer
- Liquid Level Measurement and Liquid Identification
- Water Flow Measurement
- Gas Flow Measurement

Demo Kits

- Medium Cell Level/Concentration Demo kit
- Water Flow Demonstration kit

Videos

- Selecting and mounting the transducer
- How to measure flow with Ultrasound



Urea tank Investigations – Level Measurements

- An external piezo transducer was mounted to the bottom of the tank.
- Echo signals were easily detected using TDC1000.
- For level measurements a visual level indicator was installed in the tank wall to verify liquid levels visually as well as TOF measured (see below)

1. Level: measurements

Fluid Height in Tank	TOF(us)
Full (10 cm)	145
Full - 1 cm (9cm)	131
Full - 2 cm (8cm)	118
3 cm	50
2 cm	35

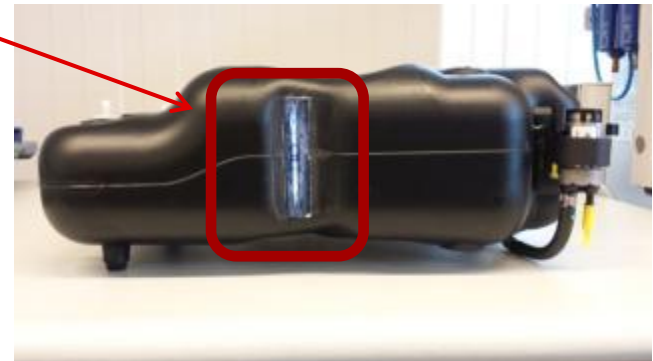
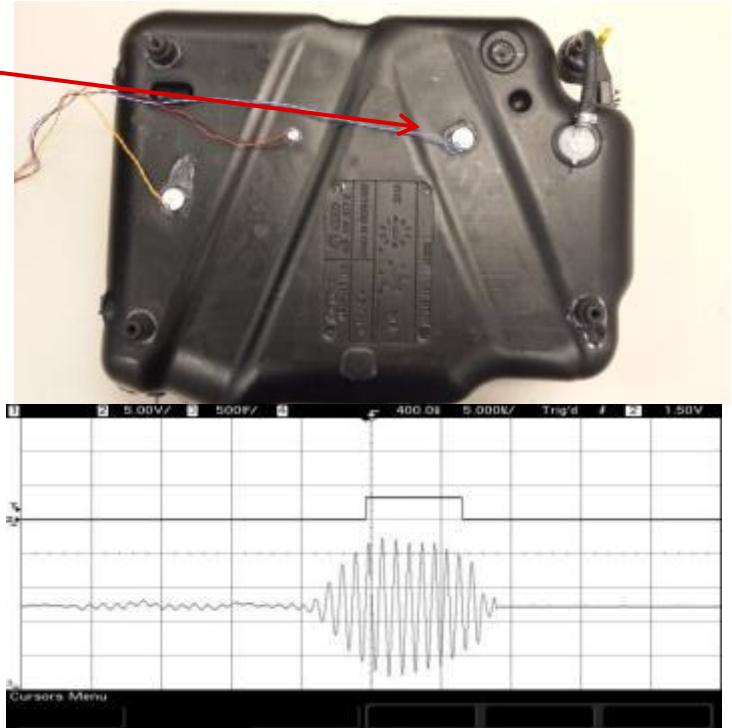
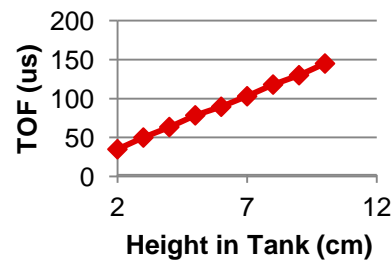

Urea tank Investigations - Part2

- Concentration/Fluid Identification requires a known reflector distance in the fluid. (distance 3cm)
- Best location/performance would have been from a horizontal TOF measurement but tank geometries drove best option to be vertical TOF with tank wall/air interface yielding best echo.
- Introduced Tank reflector was composed of similar plastic (PE) as tank material to closely match a modified tank wall/air echo.
- Resulting echo was easily detected with the TDC1000



Fluid Identification Investigations

- Due to volumes of test fluids required for tests in modified urea tank, Concentration/Fluid Identification experiments were performed using similar TOF but in smaller volume test cell. All fluids were tested at the room temperature (23 C).
- Echo distance 6cm (2 x 3cm)
- All measurements were repeatable to within 1ns accuracy

<u>Fluid</u>	<u>TOF (us)</u>
Distilled water	39534
Tap water	38445
DEF 10.0% (distilled H2O dilution)	37478
DEF 20.0% (distilled H2O dilution)	36611
DEF 30.0% (distilled H2O dilution)	36518
DEF 31.5% (distilled H2O dilution)	36469
DEF 32% (distilled H2O dilution)	36435
DEF 32.5%	36419

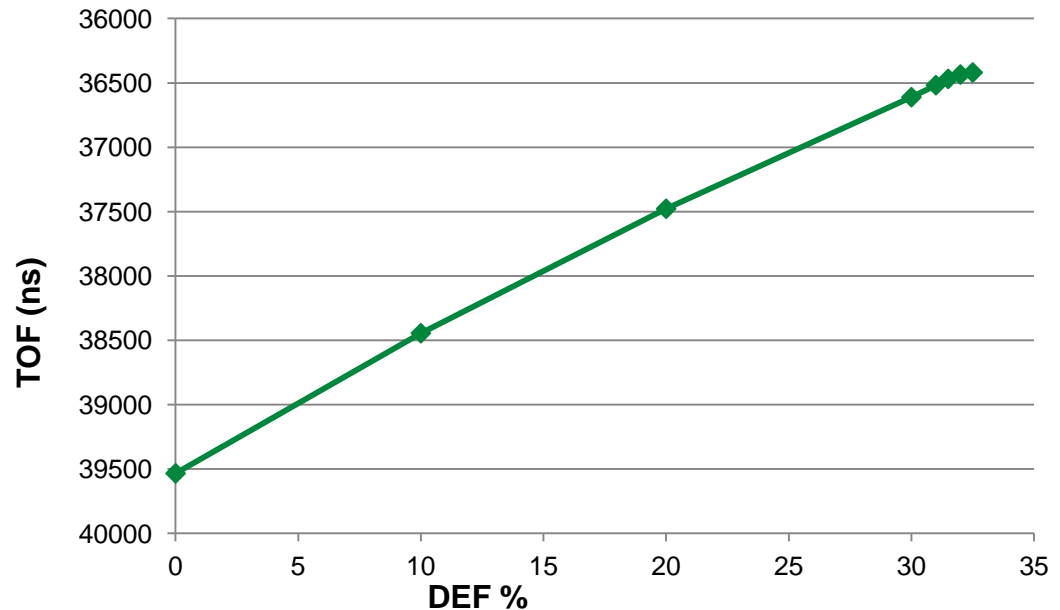

TDC1000Q Platform (Available Now)

Level Transducer

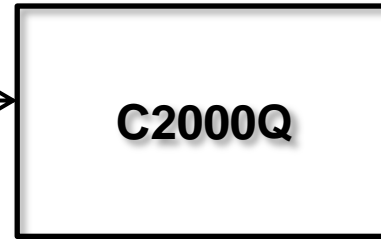
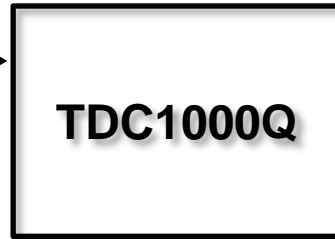

Fluid ID Transducer

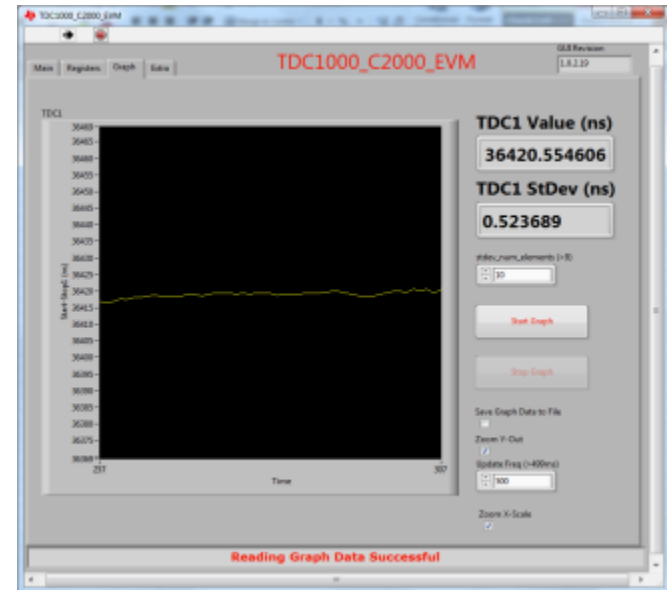
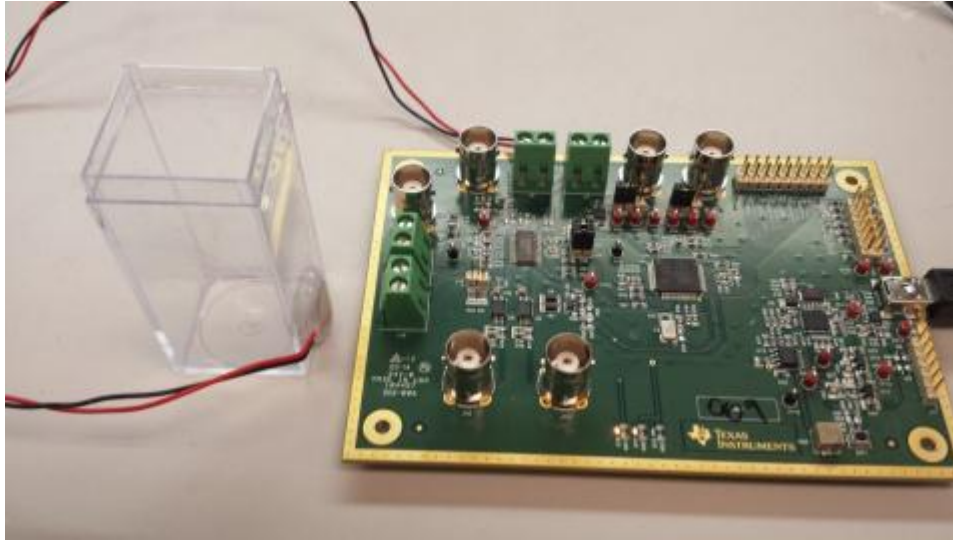

Conclusions

- Level Measurements Tests showed level measurements could easily be performed with the TDC1000 and an externally mounted piezo transducer.
- Tank investigation showed concentration measurements could easily be performed via externally mounted piezo transducer and a tank with some slight modifications.
- Fluid Identification/Concentration Tests showed the TDC1000 could easily distinguish the 0.5% DEF concentration differences and it could also identify differences between tap water and distilled water.



Fluid Concentration Measurements using TDC1000-C2000



TDC1000-C2000 EVM with Test Cell to Measure Concentration

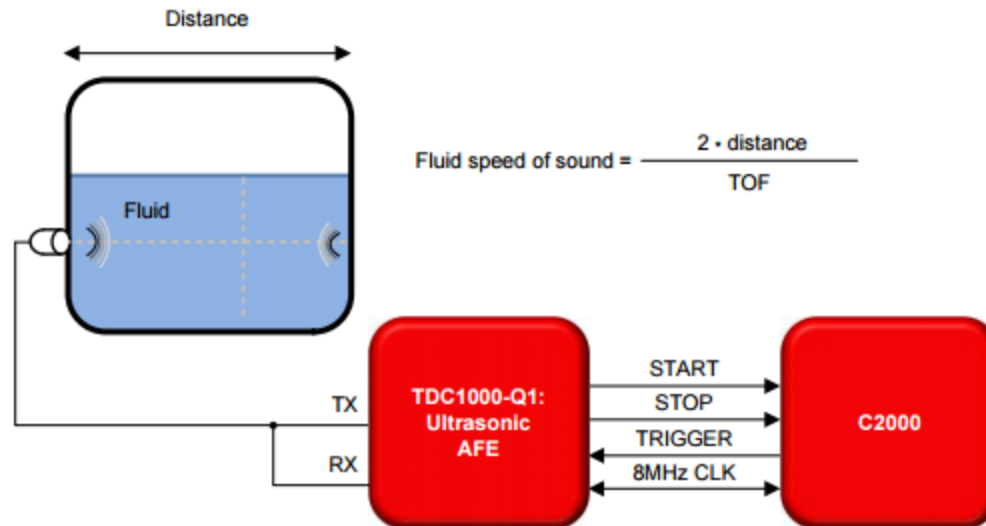

Time of Flight for Different Liquids

Table 2. Wiper Fluid

Wiper Washer Fluid	TOF(ns)	Delta T (ns) (comparing to closest dilution)
Wiper fluid	38956.56	
Wiper fluid with 40% alcohol	39089.11	-132.55
Wiper fluid with 70% alcohol	42094.35	-3005.24
Wiper fluid with 80% alcohol	44481.5	-2387.15

Table 3. Engine Oil

Engine Oil	TOF(ns)	Delta T (ns) (comparing all to Manufacturer X_5W30)
Manufacturer X 5W30	40453.08	
Manufacturer X 5W30 after 10k miles use	40299.49	153.59
Manufacturer Y 5W30	40419.56	33.52
Manufacturer X 10W40	40127.51	325.57

Table 4. Engine Coolant Dilutions

Engine Antifreeze	TOF(ns)	Delta T (ns) (comparing to closest dilution)
Coolant with 50% dilution	35462.63	
Coolant with 60% dilution	36007.78	-545.15
Coolant with 70% dilution	36711.92	-704.14
Coolant with 80% dilution	37617	-905.08
Coolant with 100% dilution	39907.86	-1207.28

- Delta time of flight numbers indicate what timing measurement accuracy each application requires
- Microprocessor based counter could easily provide the timing resolutions (100's of ns) required to resolve wiper fluid and anti-freeze
- Better than 10ns time resolution measurement would be required for engine oil measurements



TDC WEBENCH Widget

Selection Tool

- Helps select the right EVM
- Recommends what transducer to purchase
- Download TDC1000 register file for the appropriate application

Ultrasonic EVM / Transducer Selector

Level Detection Fluid ID/ Concentration Water, Gas, Heat Flow

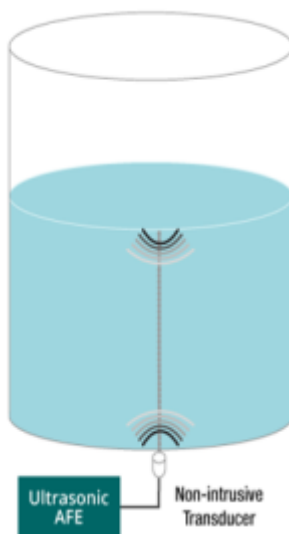

Max Fluid Level [m]: 1 Min Fluid Level [m]: 0.1

Automotive Q-grade needed?

Accuracy [mm]: 1

Medium Speed of Sound at 25°C

1480 (Water) [m/s]

Apply

Ultrasonic AFE Non-intrusive Transducer

1. Calculated expected time-of-flight (TOF) is $(135\mu\text{s to } 1.35\text{e}+3\mu\text{s}) \pm 1.35\text{e}+3\text{ns}$
Where Expected TOF = $[2 * (\text{Fluid Level})] / (\text{Fluid speed of sound})$
Accuracy = $(2 * \text{accuracy} * 10^{-3}) / (\text{Fluid speed of sound})$
2. We recommend purchasing the following evaluation module: [TDC1000-TDC7200EVM](#)
3. View the TI Design for this application: [TIDA-00322](#)
4. We recommend using the following sensors with your system:

Manufacturer	Sensor P/N	Resonant Frequency (kHz)	TDC1000 Register File
Steminc	SMD10T2R111WL	1000	Download
Steminc	SMD15T21R111WL	1000	Download
AudioWell	AW5Y15.5200AL145	1000	Download
AudioWell	AW5Y14200A	1000	Download
CTD	TPC-D1020S	1000	Download

5. Recommended documentations:
 - [TDC1000 datasheet and app notes](#)

Ultrasonic Sensing

<http://www.ti.com/lscs/ti/sensors/ultrasonic-sensing-overview.page>

Overview

Products

What's
New

Tools
& Software

Technical
Documents

Applications

Overview for Ultrasonic Sensing

Ultrasonic sensing is the measurement of the time between an ultrasonic signal being sent and received. The interval between these two signals is typically referred to as time-of-flight (ToF) and depends on the distance the ultrasonic wave travels until it is reflected due to an impedance change and the speed of the ultrasonic wave. The basic equation $time = distance / speed$ can be used to measure fluid level, fluid identification/concentration, flow, or proximity.

Benefits of Ultrasonic Sensing

- Ultra-low power consumption (~2 μ A) for battery-operated equipment
- Non-intrusive sensor and lack of contact with corrosives enables simple design and maintenance
- Flexible use in all types of tank materials and sizes

Highlights of TI's Ultrasonic Sensing technology

- Only solution on the market with automotive-qualified analog front end
- Design resources simplify adoption of ultrasonic-based solutions, minimize prototyping, and enable faster time to market



Level sensing >



Fluid ID/concentration
sensing >



Flow sensing >



Proximity sensing >

Ultrasonic Collateral

<http://www.ti.com/lstds/ti/sensors/ultrasonic-sensing-overview.page>

Ultrasonic Sensing Videos

Complete Ultrasonic Sensing Solutions

Low power, high accuracy, and flexibility for a wide range of applications



00:00 05:52

- Ultrasonic sensing solutions**
Amy provides an overview of how ultrasonic sensing works and how to TI is leveraging this technology to deliver high accuracy, low-power sensing solutions.
- How to use inexpensive transducers for ultrasonic measu...**
Matt shows us how easy it is to select and use ultrasonic transducers in your application.
- How to use ultrasonic sensing for fluid level and identifica...**
Matt demonstrates ultrasonic sensing technology for fluid level and identification with the TDC1000-TDC7200EVM.
- Fluid flow metering made easy with ultrasonic sensing**
Antony demonstrates how to simplify system design with ultrasonic sensing technology for flow metering and the TDC1000-TDC7200EVM.
- TIDA-00322 - Ultrasonic Fluid Level and Quality Measure...**
This reference design is used TDC1000-Q1 for detecting changes in fluid level or concentration changes in the fluid. Ultrasonic sensing helps achieve

Ultrasonic Sensing design support



[Visit the ultrasonic sensing forum >](#)

[Read the sensing blog >](#)

Ultrasonic EVM / Transducer Selector

Use this tool to view the recommended evaluation module (EVM) and transducer for your application:



- Fluid Level Measurement
- Fluid Identification
- Water/ Gas/ Heat Metering

[Start Design](#)

- [Overview](#)
- [Products](#)
- [What's New](#)
- [Tools & Software](#)
- [Technical Documents](#)
- [Applications](#)

Technical Documents for Ultrasonic Sensing

Featured application notes

- [How to Design with Ultrasonic Sensing \(PDF, 271KB\)](#)
- [How to Select and Mount Transducers in Ultrasonic Sensing for Level Sensing and Fluid ID \(PDF, 302KB\)](#)
- [Ultrasonic Sensing for Fluid Identification or Contamination \(PDF, 153KB\)](#)
- [Ultrasonic Sensing for Water Flow Meters and Heat Meters \(PDF, 662KB\)](#)
- [Measuring an RTD Sensor with the TDC1000 and TDC7200 \(PDF, 107KB\)](#)



TDC1000-TDC7200EVM: Ultrasonic AFE

Evaluation Board for Water Flow/Level/ID/Distance Applications

EVM Features

- Evaluation for both TDC1000 Ultrasonic AFE and TDC7200 time-to-digital converter
- On-board MSP430F5528 to process data
- User-friendly GUI Interface
- Powered by USB
- Connectors for 2 transducers & 2 RTD sensors
- 4-layer with components on top layer
- Probe connections for START, STOP, COMPIN
- 80 mm x 65 mm PC Board

Applications

- Flow: Water and heat
- Fluid level / identification / concentration
- Proximity/distance

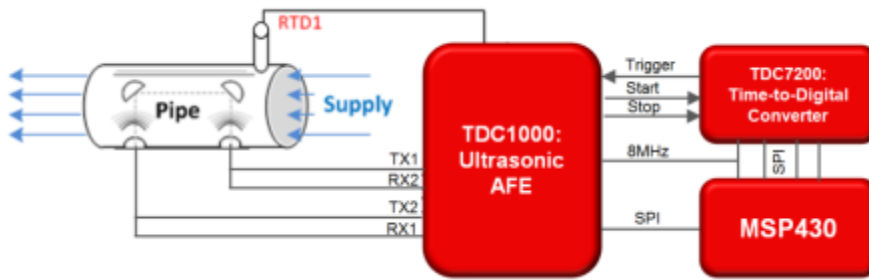

Benefits

- Picosecond timing accuracy with TDC7200 to detect zero flow
- Low power consumption to improve system battery life
- GUI Interface allows simple programmability to adapt to multiple applications and varying tank or pipe sizes
- Ease-of-use: No external power supply needed
- Low BOM cost solution

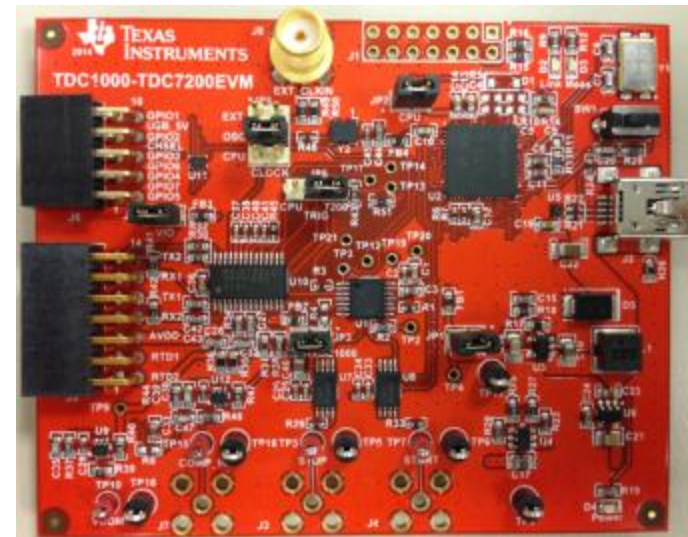

TDC1000-C2000EVM: Ultrasonic AFE

Evaluation Board for Automotive Level & Identification

Features

- Evaluation for TDC1000-Q1 Ultrasonic AFE
- On-board C2000 MCU to process data
- User-friendly GUI Interface
- Powered by USB
- Connectors for 2 transducers & 2 RTD sensors
- 4-layer with components on top layer
- Probe connections for START, STOP, COMPIN
- 80 mm x 65 mm PC Board

Applications

- Automotive Fluid level / ID / concentration
- Proximity / distance

Benefits

- AEC-Q100 qualified for automotive applications
- Low power consumption to improve system battery life
- GUI Interface allows simple programmability to adapt to multiple applications and varying tank sizes
- Ease-of-use: No external power supply needed
- Low BOM cost solution

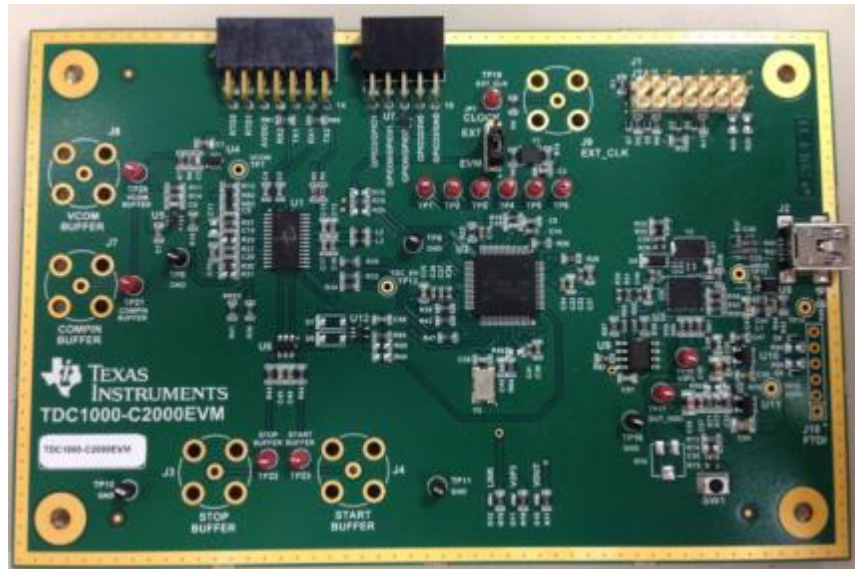
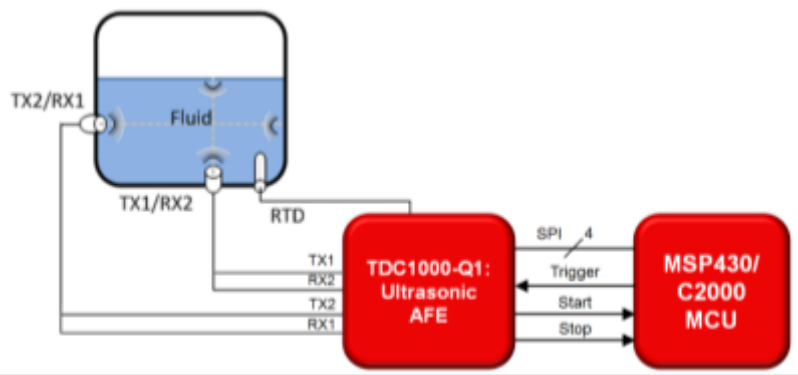

Automotive Ultrasonic Sensing Fluid Level/Quality Measurement Reference Design



Available Now

TI Designs Number: TIDA-00322

Solution Features

- Fully integrated Dual Channel Ultrasonic Analog Front End (AFE)
- External RTD Measurement capability of the fluid being monitored
- 30 Volt transducer drive circuit
- Input voltage range of 6V to 60V with reverse battery protection
- CAN interface
- UART interface

Solution Benefits

- Integrated solution simplifies system design
- External RTD connection to AFE to measure fluid temperature for speed of sound compensation
- Higher drive voltage allows for a deeper tank measurements
- Operates directly off a 12V automotive battery and protects against reverse battery connection errors.
- Designed to communicate over industry standard automotive CAN bus
- Enables a industry standard interface for connection with supplied GUI

Tools & Resources



- [TIDA-00322 Tools Folder](#)
- Test Data/Design Guide
- Design Files: Schematics, BOM and BOM Analysis, Design Files

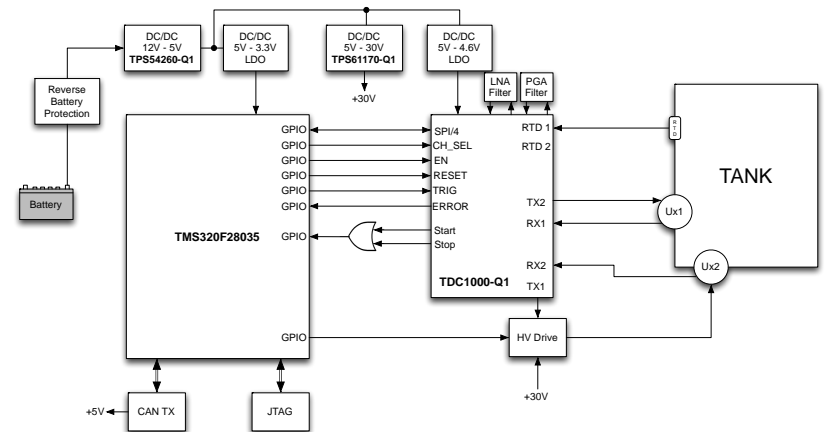

Hall Effect Sensor Solutions

What is the *Hall-effect*?

- A sensing technology that detects the presence of a magnetic field
- Mainly used to sense position, speed, and acceleration

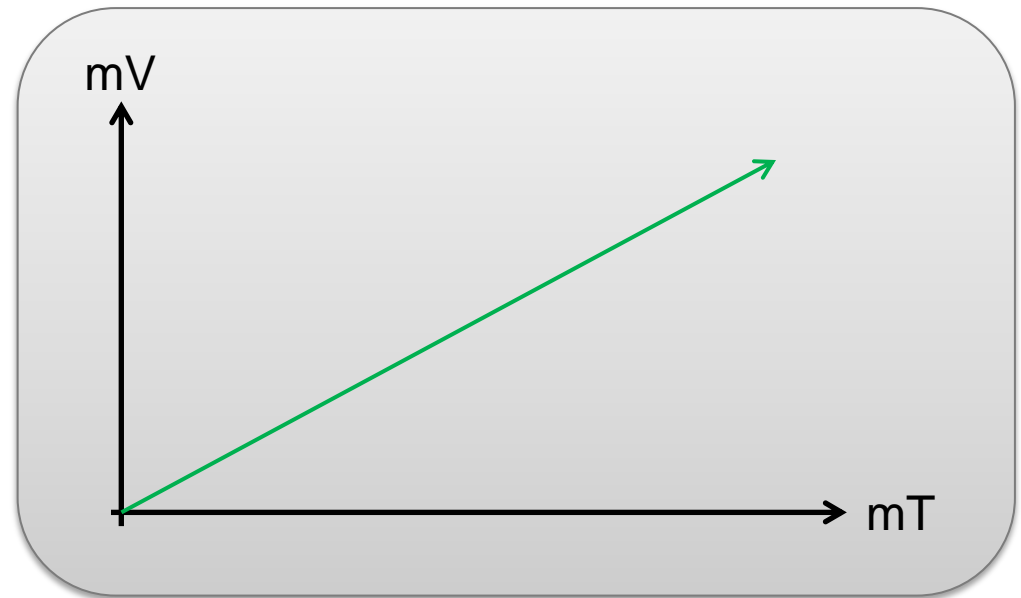
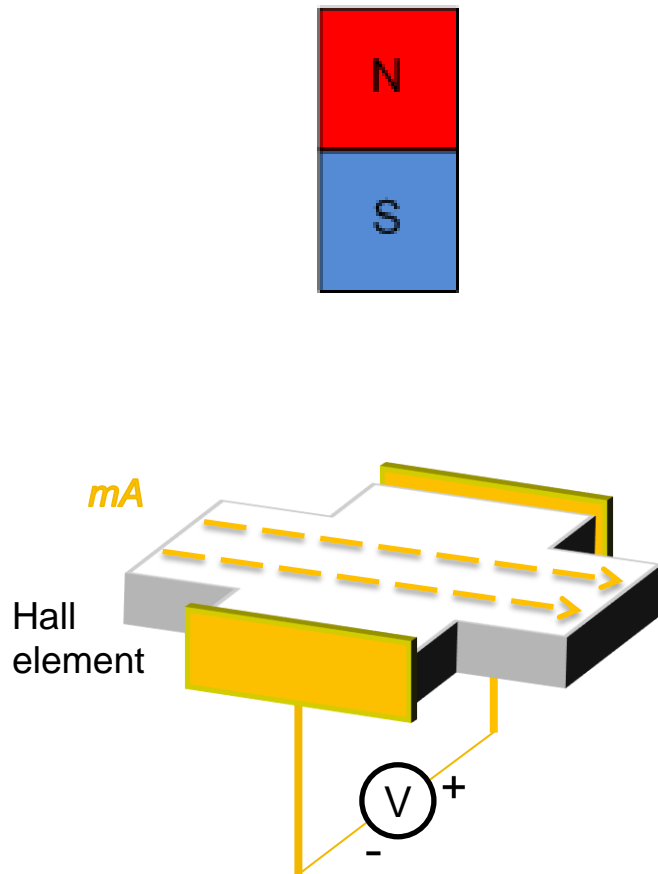

The current's positive charge carriers are deflected to one side as a magnetic field is applied (the *Lorentz force*), inducing an EMF (Hall voltage) across the Hall element

DRV5000: 3 Types of Output

✓ DRV501x: digital latch

Ex. DRV5013
Drop-in replacement packages

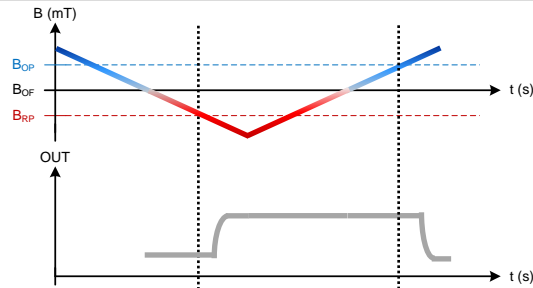
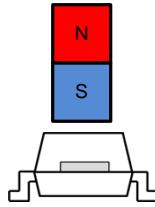

Ex. digital latch

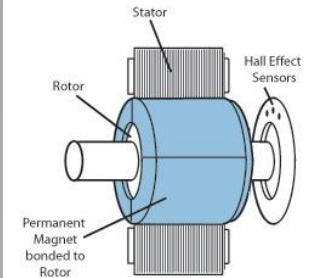

✓ DRV502x/3x: digital switch

Ex. DRV5023
Drop-in replacement packages

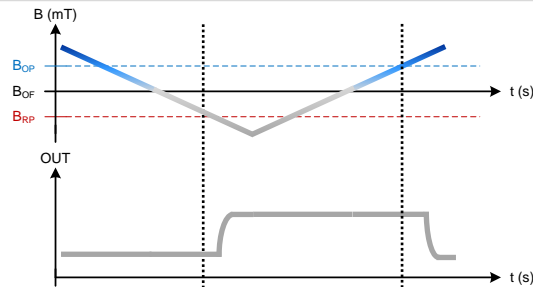
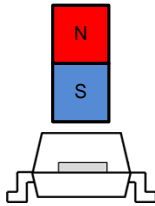

Ex. digital switch

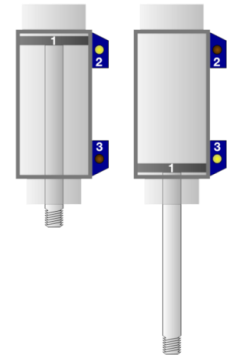

✓ DRV505x: analog bipolar output

Ex. DRV5053
Drop-in replacement packages

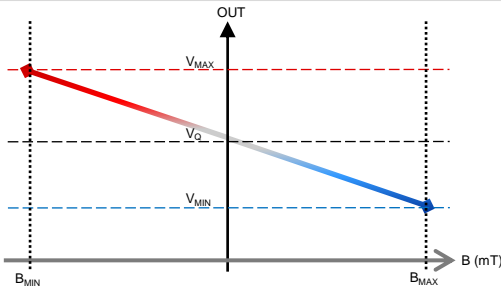
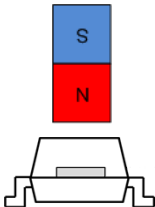

Ex. analog linear

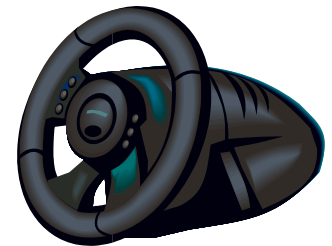

DRV50x3: TI's first generation Hall sensors

✓ DRV5013: digital latch

Sensitivity variants (Bop/Brp)

DRV5013AD	+3/-3mT
DRV5013AG	+6/-6mT
DRV5013BC	+12/-12mT

Pin-to-pin with Infineon TLE4946, A122x & others

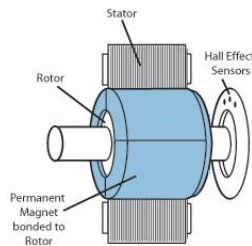

✓ DRV5023/33: digital switch

Sensitivity variants (Bop/Brp)

DRV5023AJ	+9/+3mT
DRV5023BI	+16/+6mT
DRV5033AJ*	+9/+3, -9/-3mT

*Omnipolar switch

Pin-to-pin with Infineon TLE4906, A120x & others

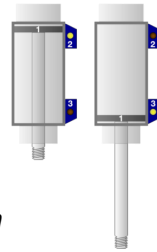

✓ DRV5053: analog bipolar output

Sensitivity variants (Bop/Brp)

DRV5053OA	-10 mV/mT
DRV5053PA	-20 mV/mT
DRV5053RA	-40 mV/mT
DRV5053VA	-80 mV/mT

Sensitivity variants (Bop/Brp)

DRV5053CA	+20 mV/mT
DRV5053EA	+40 mV/mT



Device options

2 package options available:

- SOT-23 (DBZ) for compact applications

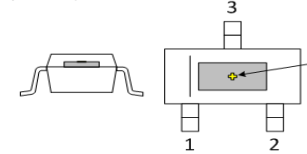

- TO-92S (LPG) to place Hall as close as possible

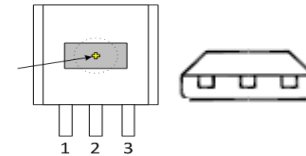

Temp/grades available:

- Industrial temp: -40 to 125
- AEC-Q100 qualified: -40 to 125 (Grade 1)
- AEC-Q100 qualified: -40 to 150C (Grade 0)

Features/Value Adds:

- Large voltage operating range (2.5V-38V)
- Supports high-volt load dump (up to 40V)
- Power-on "ready" pulse
- Fast power-on time (35 usec)
- Fast switching time (less than 15usec)
- Reverse supply protection (up to -22V)
- Overcurrent protection

Capacitive Sensor Solution

Capacitive Sensing Overview

Capacitive sensing

Sensor is any conductor:

- Copper on PCB
- Conductive ink
- ITO
- Piece of metal

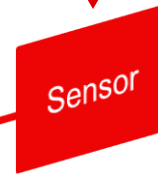

Measure:

- Motion
- Presence
- Level

Benefits of Capacitive Sensing

- ⊙ Low-cost, flexible sensor
- ⊙ Highly reliable by virtue of being contactless
- ⊙ Low power solution
- ⊙ Very sensitive to both conductors and non-conductors
- ⊙ Remote, multi-channel sensing capable

Benefits

Cap Sensing Applications

Short-Range (<15cm) Proximity Sensing

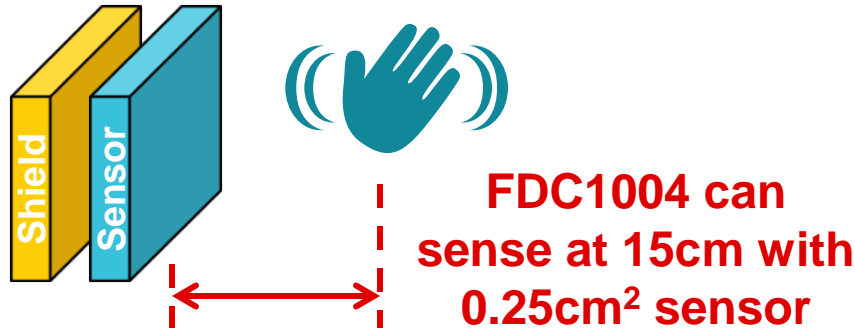

<p>Uses</p>	<ul style="list-style-type: none"> • Display wakeup, door activation, presence detection
<p>Target End Equipment</p>	<ul style="list-style-type: none"> • White goods: refrigerator, coffee machine, soap dispenser • Automotive: car door sensor • Industrial: thermostat, proximity sensors, displays, HMI
<p>System Benefits</p>	<ul style="list-style-type: none"> • Minimum sensor size for a given sensing distance • Maximum sensing distance for a given sensor size

Cap Sensing Applications

Long-Range (up to 50cm) Proximity Sensing

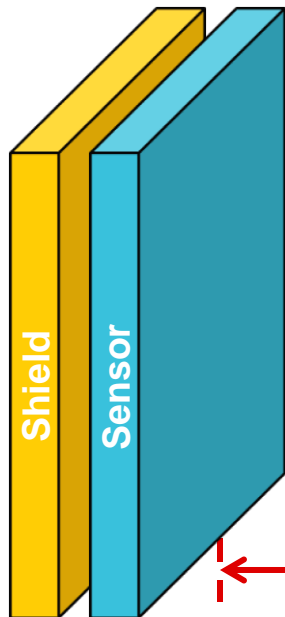

FDC1004 can sense at 50cm with 169cm² sensor



Uses	<ul style="list-style-type: none">• Display wakeup, door activation, on/off activation
Target End Equipment	<ul style="list-style-type: none">• Automotive: door kick sensor• Industrial: HMI, plumbing fixtures• Consumer: laptops, computer screens
System Benefits	<ul style="list-style-type: none">• Minimum sensor size for a given sensing distance• Maximum sensing distance for a given sensor size

Cap Sensing Applications

Collision Avoidance

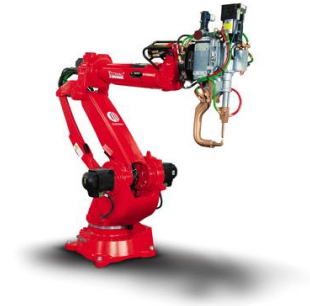
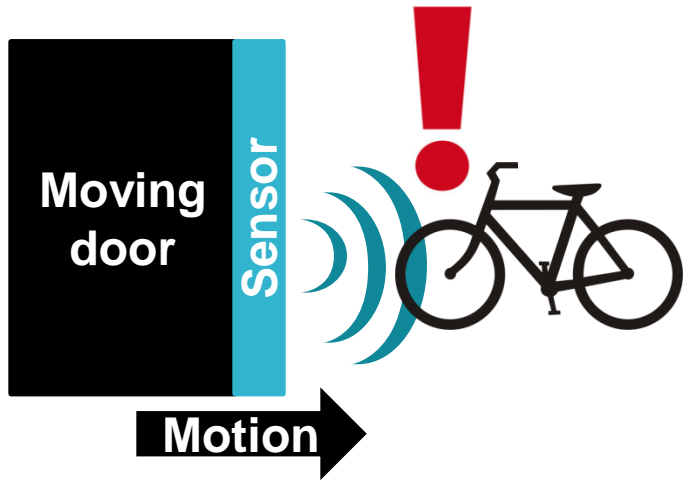

Uses	<ul style="list-style-type: none">• Collision warning, emergency brake/stop
Target End Equipment	<ul style="list-style-type: none">• Automotive: automatic doors and gates• Industrial: elevators, garage doors, automatic doors, robots
System Benefits	<ul style="list-style-type: none">• Can use large sensors for maximum sensing distance and area coverage

Cap Sensing Applications

Coarse Gesture Sensing



Left Sensor

Right Sensor

Left/right sensing

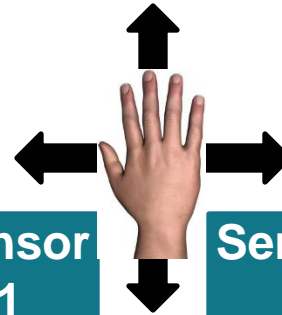

Sensor 1

Sensor 2

Sensor 3

Left/right, up/down sensing



<p>Uses</p>	<ul style="list-style-type: none"> • User controls
<p>Target End Equipment</p>	<ul style="list-style-type: none"> • White goods: dishwasher, stove, fan • Automotive: doors, infotainment display • Personal electronics: audio equipment, thermostat
<p>System Benefits</p>	<ul style="list-style-type: none"> • Make insensitive to environmental changes, interferers • Sense up to 70cm away • Sense through glass and plastic

Cap Sensing Applications

Ice/water/vapor detection

Liquid
Sensor

Liquid, condensation,
rain, leak sensing

Ice/snow
Sensor

Ice, snow sensing



Uses	<ul style="list-style-type: none"> Rain & condensation sensing, leak detection, ice buildup
Target End Equipment	<ul style="list-style-type: none"> White goods: coffee maker, refrigerator, freezer Automotive: windshield, windows, roof, wiper control, defog Industrial: process control, leak sensor
System Benefits	<ul style="list-style-type: none"> Sense through plastic and glass Make insensitive to environmental changes & interferers

Cap Sensing Applications

Liquid level detection

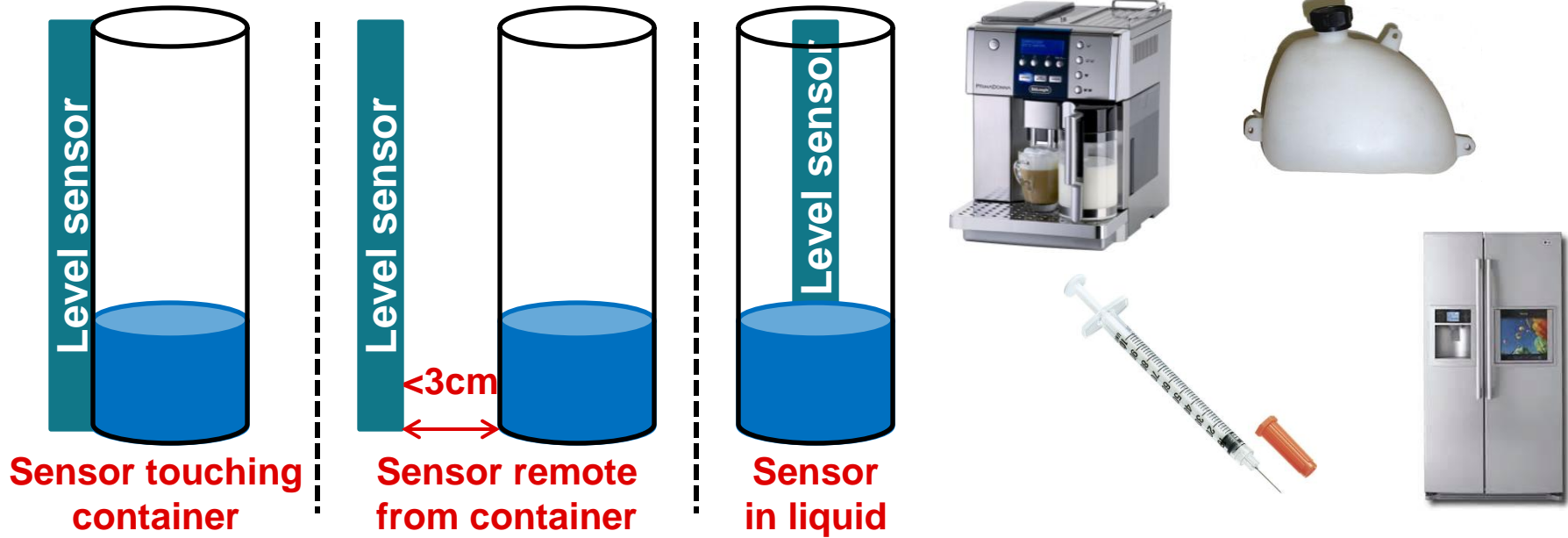

Uses	<ul style="list-style-type: none"> • Measure liquid level in a container, measure flow rate
Target End Equipment	<ul style="list-style-type: none"> • White goods: coffee maker, refrigerator • Automotive: fuel level, washer fluid level, coolant level • Industrial: process control, drug pens, insulin pumps
System Benefits	<ul style="list-style-type: none"> • Low-cost level sensor • Can achieve 0.5% level accuracy, robust to interference

FDC1004Q – Grade 1 Qualified

4-Ch Cap-to-Digital Converter for Capacitive Sensing

Features

- Four cap sensing channels
- 100pF maximum input offset capacitance with large input full-scale range: +/-15pF
- Two 400pF shield drivers
- Low noise floor: 500pF at 100 samples/second
- Programmable sampling rate: 100/200/400 samples/sec
- Low power: 750uA active, 29uA standby at 3.3V
- 10-pin VSSOP package

Applications

- **Liquid level sensing** in fuel tanks, washer fluid containers, coolant containers
- **Collision avoidance** for automotive doors
- **Proximity and simple gesture sensing** for automotive doors, kick sensors, and automotive infotainment
- **Ice/rain/condensation sensing** for rain sensors, windshield fog sensors, roof ice/snow sensors

Benefits

- Four channels enables multiple sensors in minimum system size and cost
- Large offset capacitance enables remote sensing and use of large sensors
- Large shield reduces impact of interferers, focuses sensing, and makes system robust to temp & humidity
- Low noise floor allows for minimum sensor size
- Programmable sampling rate enables optimal speed / performance tradeoff

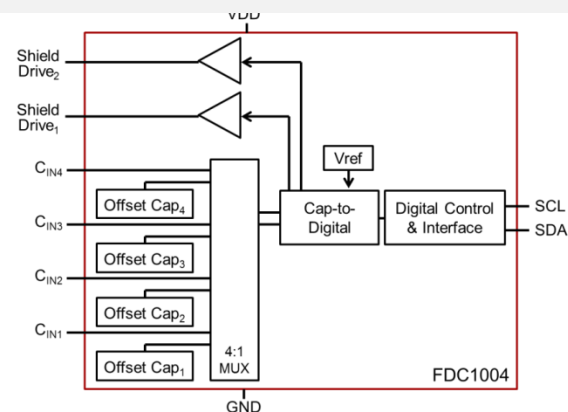

Shielding in Capacitive Sensing

Focus / Direct the Sensing

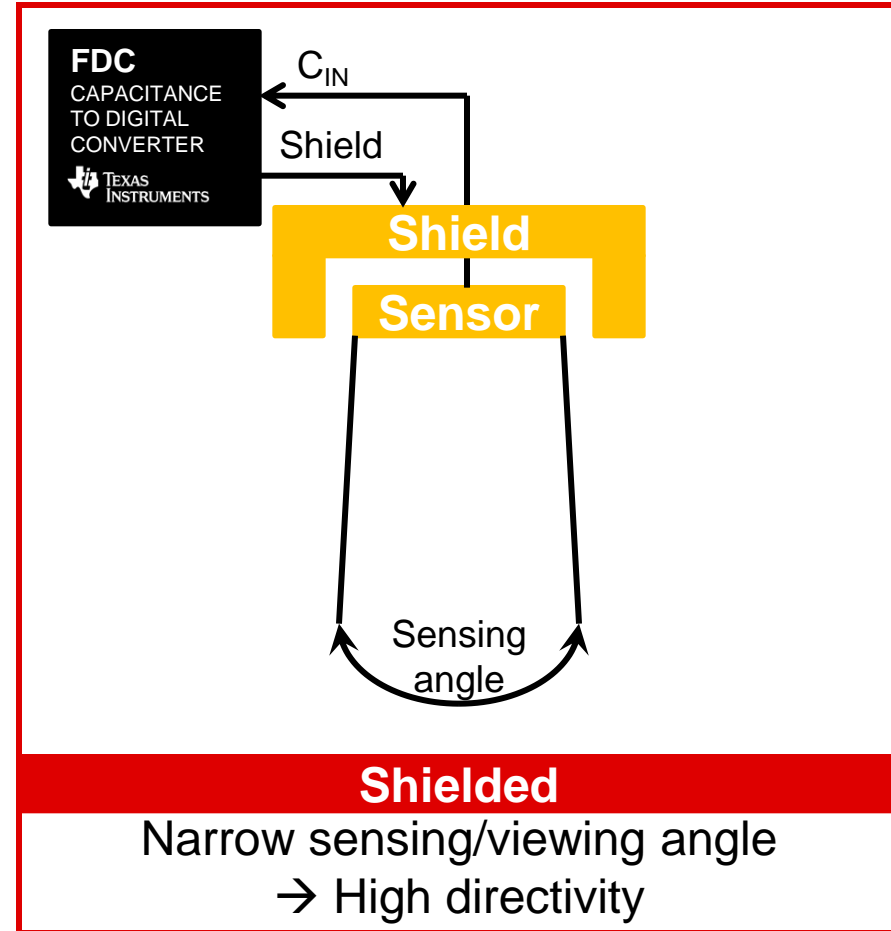
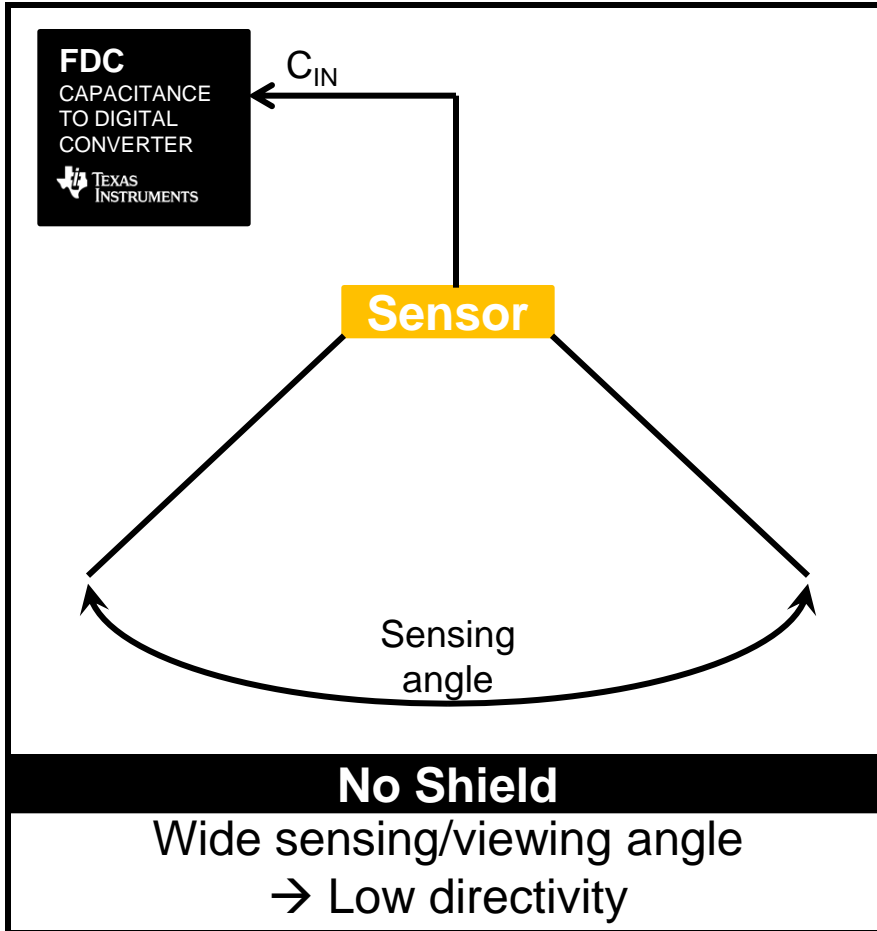

Humidity Sensor Solution

An Introduction to Humidity

- What's RELATIVE HUMIDITY?

- Ratio (at a fixed temperature) between *actual water vapor* and *saturation water vapor* expressed as percentage (saturation is the max water vapor)

$$\%RH = \frac{\text{Actual Water Vapor}}{\text{Saturation Water Vapor}} \text{ (fixed temperature)}$$

Saturation → water vapor start to condense

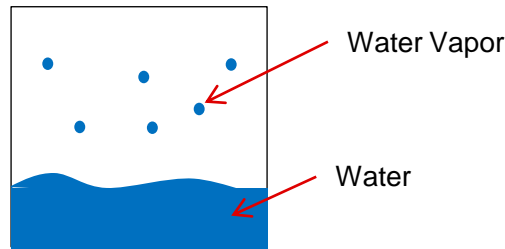

- %RH change significantly with the temperature
 - +1°C variation → -4%RH relative humidity
 - Precise temperature measurement is needed
- Dew Point - Temperature at which moisture condense (air is saturated)
 - to identify this temperature a precise temperature sensor is needed.
 - Avoiding the condensation is important in several applications as automatic windshield defog, industrial process ect.
 - Combination of accurate humidity and temperature sensor is needed

TI's Humidity Sensing Solution

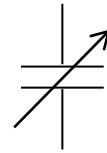
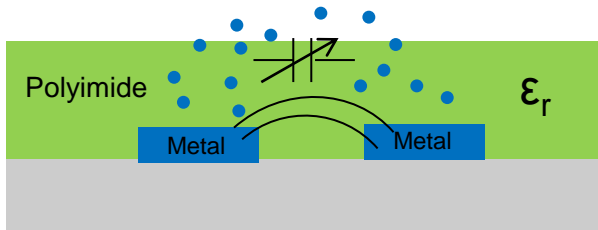

Working Principles

Fringe capacitance changes as water is absorbed/desorbed by polyimide

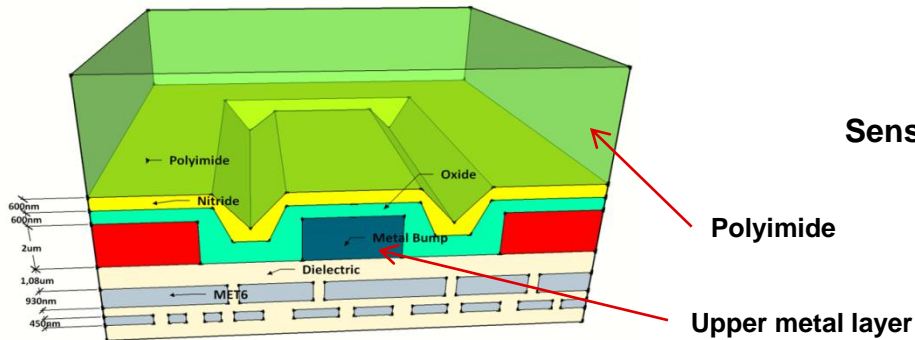

Implementation

Sensor is integrated using standard technology (sensor cross-section)

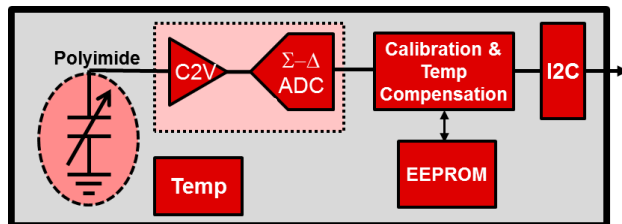

Block diagram

Readout electronics converts cap value variation into RH value

HDC1000: Low Power Humidity and Temperature Digital Sensor

Features

▪ Relative Humidity Range	0% to 100%
▪ Humidity Accuracy	$\pm 2\%$
▪ Supply Current (Measuring)	180 μA
▪ Avg. Supply Current (H+T @ 1sps)	1.3 μA
▪ Temperature Accuracy	$\pm 0.3^\circ\text{C}$
▪ Temperature Range (Recommended)	-20°C to $+85^\circ\text{C}$
▪ Temperature Range (Operating)	-40°C to $+125^\circ\text{C}$
▪ Operating Voltage	3V to 5V
▪ Package	8 pin WCSP (1.59 x 2.04mm)

Benefits

- Completely integrated humidity and temperature IC provides guaranteed performance
- Fully calibrated sensor enables quick time-to-market
- Very low power consumption
- Small package size supports compact designs

Applications

- HVAC
- White goods (dryer, fridge, microwave, dishwasher)
- Printers
- Handheld Meters
- Camera Defog
- Smart Thermostats and Room Monitors
- Medical Devices

