

Automotive Digital Measurement Solution

Woo, Jun Hyung



Table of Content

- **Automotive Market Trend**
- Different types of communication
- Keysight Solutions for Automotive Communication Test
 - CAN, LIN, SENT, CXPI, FlexRay, LVDS, BroadR-Reach
 - CAN, CANFD, CANdbc labs, SENT/CXPI examples
- Probing requirements
- High Speed Digital Application for Automotive
 - USB solution
 - DDR solution

Innovation in automotive technology

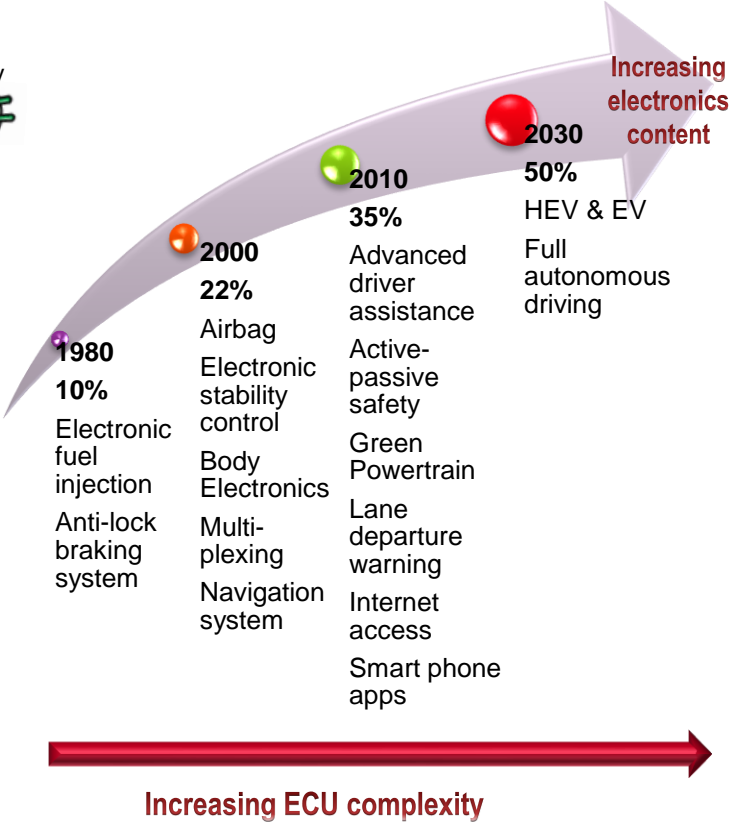
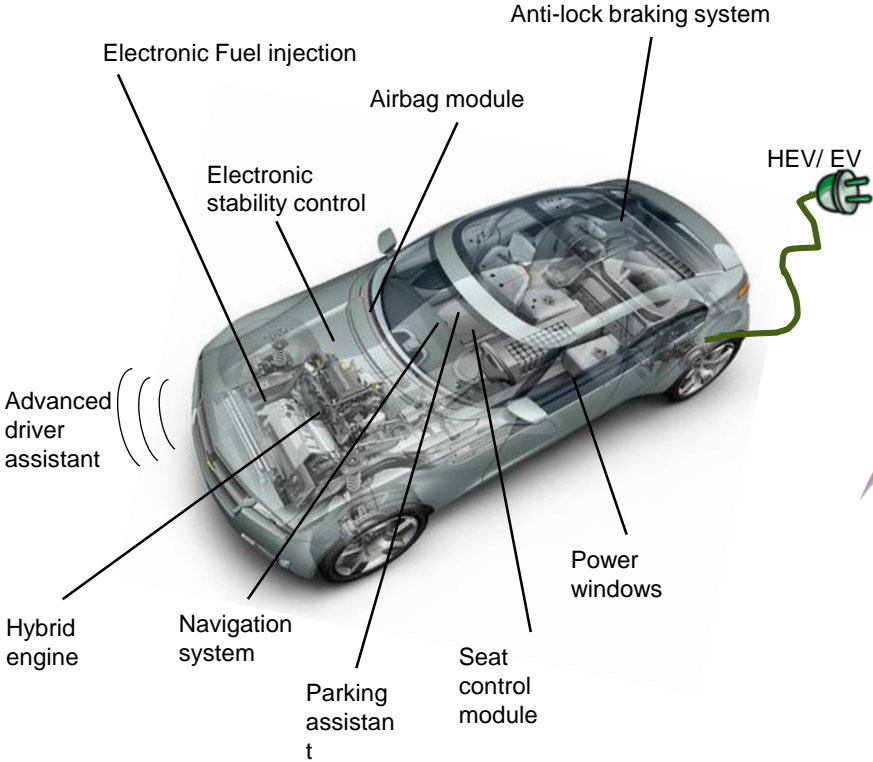

The beginning of in-vehicle communication

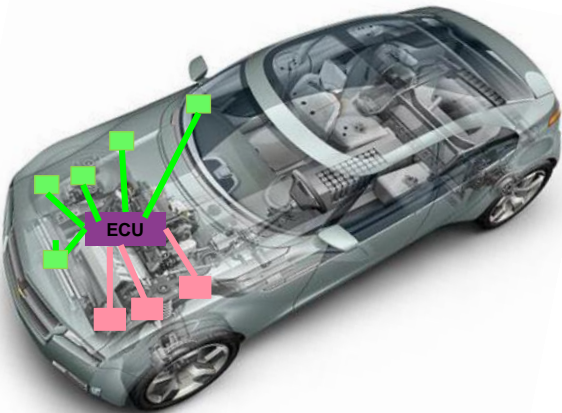

Stand-alone Control Unit

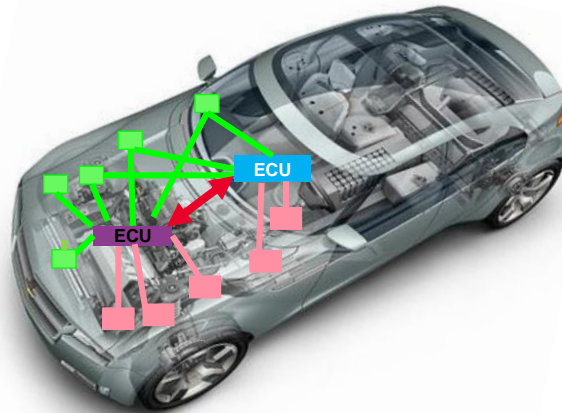

Point-to-Point communication

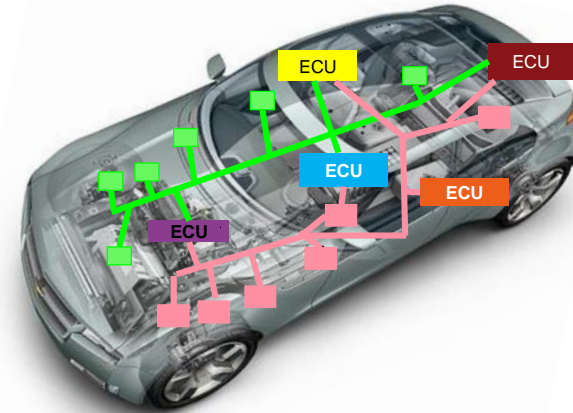











Multiplexed communication (shared medium)

Table of Content

- Automotive Market Trend
- **Different types of communication**
- Keysight Solutions for Automotive Communication Test
 - CAN, LIN, SENT, CXPI, FlexRay, LVDS, BroadR-Reach
 - CAN, CANFD, CANdbc labs, SENT/CXPI examples
- Probing requirements
- High Speed Digital Application for Automotive
 - USB solution
 - DDR solution

Automotive communication bus protocol – the variety of format





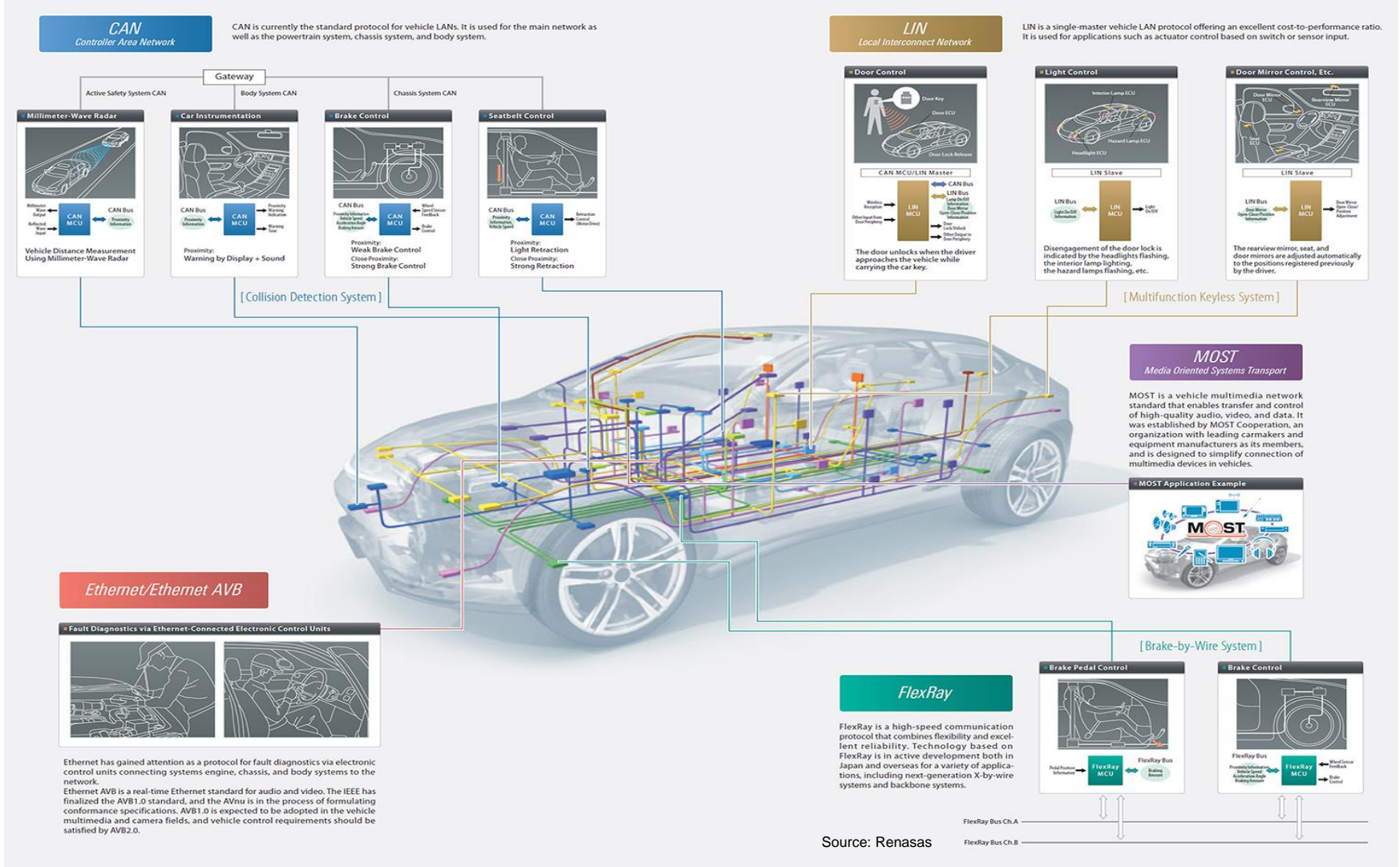





| Feature | CAN (Controller Area Network)  | LIN (Local Interconnect Network)  | FlexRay  | SENT (Single Edge Nibble Transmission)  | CXPI (Clock Extension Peripheral Interface)  | LVDS (Low Voltage Differential Signaling)  | MOST (Media Oriented Systems Transport)  | BroadR-Reach (100Base-T1)  | AVB (Audio Video Bridging)  | A2B (Automotive Audio Bus)  |
|--------------------------------|--|--|---|--|---|---|---|---|--|--|
| Application domains | Powertrain, chassis | Body electronics | Safety critical | Safety-critical application | Body electronics | Camera, displays | Multimedia, telematics | ADAS, connected car | Infotainment, connected car, ADAS | Infotainment (audio) |
| Architecture / topology | Multi-master (10-30 nodes) | Single master (2-10 slaves) | Multi-master (<64 nodes) | Point-to-point sensor to controller | Master-slave | Point-to-point/multipoint / multipoint | Multi-master (<64 nodes) | Centralized network topology | Switch gateway | Master-slave (8 slave) |
| Data rate | 500kbps | 19.2kbps | 10Mbps | 30kbps | 20kbps | 4Gbps | 150Mbps | 100Mbps | >100Mbps | 50Mbps |
| Physical layer | Differential 2 wire twisted pair | 1-wire | Differential 2 wire twisted pair | 1-wire | 1-wire | Shielded twisted pair copper cable | 2-wire (optical fiber/ electrical) | Unshielded single twisted pair | Unshielded single twisted pair | Unshielded single twisted pair |
| Date | 1983 | 2001 | 2005 | 2007 | 2015 | 2002 | 2001 | 2011 | 2011 | 2013 |
| Cost/node | \$\$ | \$ | \$\$\$\$\$\$ | \$ | \$ | \$\$\$\$ | \$\$\$\$\$\$\$\$ | \$\$\$\$\$\$\$\$ | | |
| Standard | ISO 11898 | ISO 17987 | ISO 10681 | SAE J2716 | SAE J3076 | ANSI TIA/EIA-644-A, TIA/EIA-899 (M-LVDS) | | IEEE 802.3BW | IEEE802.1 | (by Analog Devices) |
| Characteristic | <ul style="list-style-type: none"> - Low speed / fault-tolerant (125kbps) - High-speed (1 Mbps) - Flexible data (up to 10Mbps)  | Cheap | X-by-Wire, Reliable | 1-way, digital precision | Alternative to LIN for multiplexing real-time HMI system | Low power, high speed, low noise | Lighter, meet EMC requirement | Lower cost, reduce weight | Talker and listener via gateway | Simpler, 32 upstream and downstream audio channels |

Application Domain



Source: Renesas

Automotive communication bus protocol – the variety of format

| Feature | CAN (Controller Area Network)  | LIN (Local Interconnect Network)  | FlexRay  | SENT (Single Edge Nibble Transmission)  | CXPI (Clock Extension Peripheral Interface)  | LVDS (Low Voltage Differential Signaling)  | MOST (Media Oriented Systems Transport)  | BroadR-Reach (100Base-T1)  | AVB (Audio Video Bridging)  | A2B (Automotive Audio Bus)  |
|--------------------------------|--|--|---|--|---|---|---|---|--|--|
| Application domains | Powertrain, chassis | Body electronics | Safety critical | Safety-critical application | Body electronics | Camera, displays | Multimedia, telematics | ADAS, connected car | Infotainment, connected car, ADAS | Infotainment (audio) |
| Architecture / topology | Multi-master (10-30 nodes) | Single master (2-10 slaves) | Multi-master (<64 nodes) | Point-to-point sensor to controller | Master-slave | Point-to-point/multipoint / multipoint | Multi-master (<64 nodes) | Centralized network topology | Switch gateway | Master-slave (8 slave) |
| Data rate | 500kbps | 19.2kbps | 10Mbps | 30kbps | 20kbps | 4Gbps | 150Mbps | 100Mbps | >100Mbps | 50Mbps |
| Physical layer | Differential 2 wire twisted pair | 1-wire | differential 2 wire twisted pair | 1-wire | 1-wire | Shielded twisted pair copper cable | 2-wire (optical fiber/ electrical) | Unshielded single twisted pair | Unshielded single twisted pair | Unshielded single twisted pair |
| Date | 1983 | 2001 | 2005 | 2007 | 2015 | 2002 | 2001 | 2011 | 2011 | 2013 |
| Cost/node | \$\$ | \$ | \$\$\$\$\$\$ | \$ | \$ | \$\$\$\$ | \$\$\$\$\$\$\$\$ | \$\$\$\$\$\$\$\$ | | |
| Standard | ISO 11898 | ISO 17987 | ISO 10681 | SAE J2716 | SAE J3076 | ANSI TIA/EIA-644-A, TIA/EIA-899 (M-LVDS) | | IEEE 802.3BW | IEEE802.1 | (by Analog Devices) |
| Characteristic | <ul style="list-style-type: none"> - Low speed / fault-tolerant (125kbps) - High-speed (1 Mbps) - Flexible data (up to 10Mbps)  | Cheap | X-by-Wire, Reliable | 1-way, digital precision | Alternative to LIN for multiplexing real-time HMI system | Low power, high speed, low noise | Lighter, meet EMC requirement | Lower cost, reduce weight | Talker and listener via gateway | Simpler, 32 upstream and downstream audio channels |

Cost vs bit rate

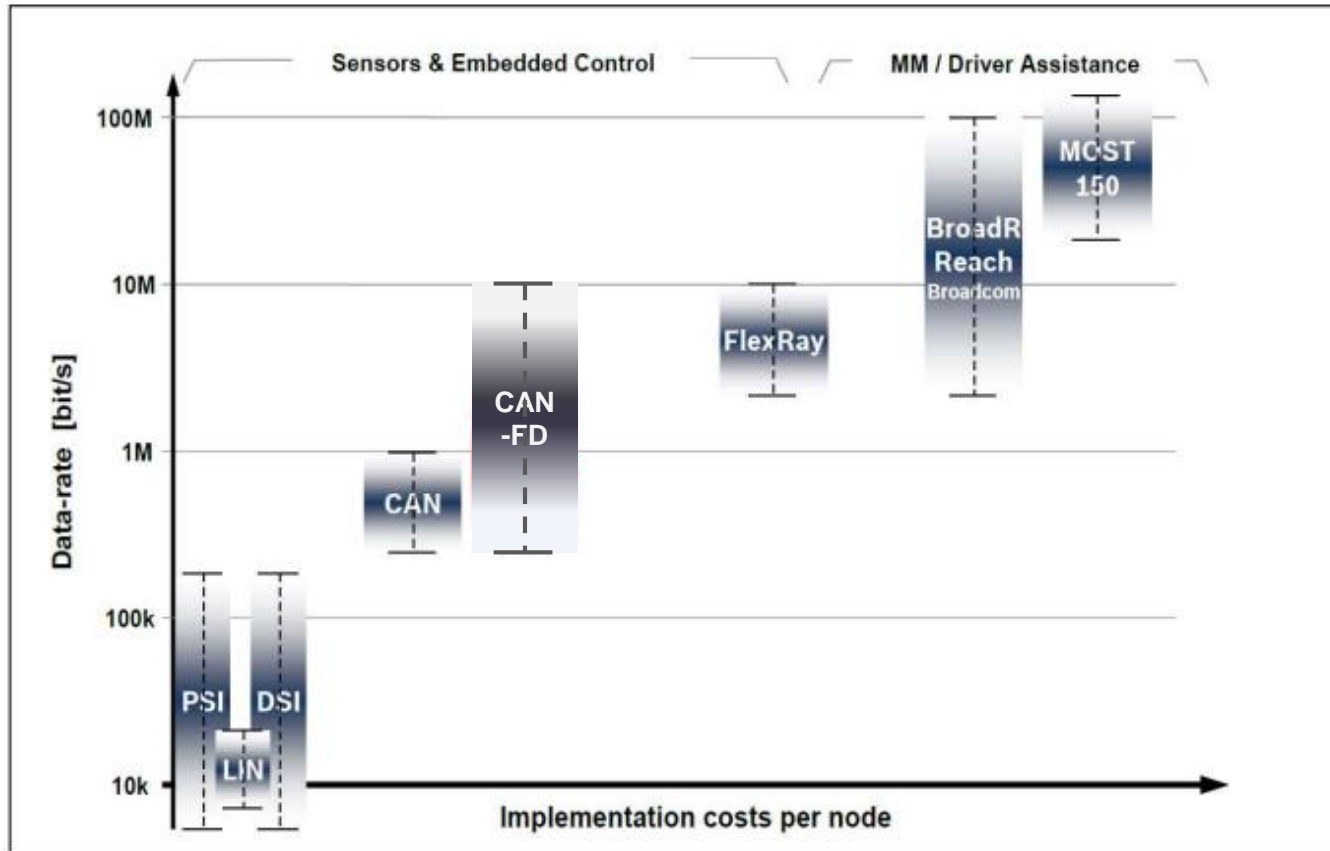

Source: Robert Bosch Automotive Electronics: "CAN FD – CAN with Flexible Data-rate" (2011)

Simpler, lighter and cheaper



COST?
Weight?













- COST - Cabling is the 3rd highest cost component in a car (engine 1st, chassis 2nd)
 - Harness are ONE at a time with 50% of cost in labor
- WEIGHT - Cabling is the 3rd heaviest component in car, (chassis 1st, engine 2nd)

"The replacement of wiring harness with LANs in the four doors of BMW reduced the weight by 15 kg"

Mentioned in "Expanding automotive electronic system IEEE computer", Jan 2002

- LVDS cable vs twisted pair Ethernet cabling
 - LVDS is bulky, heavy and expensive
 - Single unshielded twisted pair Ethernet – reduce connectivity by 80%, cabling weight by 30% (lighter and cheaper)
- (from <http://www.broadcom.com/blog/automotive-technology-2/the-case-for-ethernet-in-cars/>)

Automotive communication bus protocol – the variety of format

| Feature | CAN (Controller Area Network)  | LIN (Local Interconnect Network)  | FlexRay  | SENT (Single Edge Nibble Transmission)  | CXPI (Clock Extension Peripheral Interface)  | LVDS (Low Voltage Differential Signaling)  | MOST (Media Oriented Systems Transport)  | BroadR-Reach (100Base-T1)  | AVB (Audio Video Bridging)  | A2B (Automotive Audio Bus)  |
|--------------------------------|---|--|---|--|---|---|---|---|--|--|
| Application domains | Powertrain, chassis | Body electronics | Safety critical | Safety-critical application | Body electronics | Camera, displays | Multimedia, telematics | ADAS, connected car | Infotainment, connected car, ADAS | Infotainment (audio) |
| Architecture / topology | Multi-master (10-30 nodes) | Single master (2-10 slaves) | Multi-master (<64 nodes) | Point-to-point sensor to controller | Master-slave | Point-to-point/multipoint / multipoint | Multi-master (<64 nodes) | Centralized network topology | Switch gateway | Master-slave (8 slave) |
| Data rate | 500kbps | 19.2kbps | 10Mbps | 30kbps | 20kbps | 4Gbps | 150Mbps | 100Mbps | >100Mbps | 50Mbps |
| Physical layer | Differential 2 wire twisted pair | 1-wire | differential 2 wire twisted pair | 1-wire | 1-wire | Shielded twisted pair copper cable | 2-wire (optical fiber/ electrical) | Unshielded single twisted pair | Unshielded single twisted pair | Unshielded single twisted pair |
| Date | 1983 | 2001 | 2005 | 2007 | 2015 | 2002 | 2001 | 2011 | 2011 | 2013 |
| Cost/node | \$\$ | \$ | \$\$\$\$\$\$ | \$ | \$ | \$\$\$\$ | \$\$\$\$\$\$\$\$ | \$\$\$\$\$\$\$ | | |
| Standard | ISO 11898 | ISO 17987 | ISO 10681 | SAE J2716 | SAE J3076 | ANSI TIA/EIA-644-A, TIA/EIA-899 (M-LVDS) | | IEEE 802.3BW | IEEE802.1 | (by Analog Devices) |
| Characteristic | <ul style="list-style-type: none"> - Low speed / fault-tolerant (125kbps) - High-speed (1 Mbps) - Flexible data (up to 10Mbps)  | Cheap | X-by-Wire, Reliable | 1-way, digital precision | Alternative to LIN for multiplexing real-time HMI system | Low power, high speed, low noise | Lighter, meet EMC requirements | Lower cost, reduce weight | Talker and listener via gateway | Simpler, 32 upstream and downstream audio channels |

Audio Video Bridging (AVB)

- Standard by Avnu Alliance
- Simpler cabling lower weight, increase reliability
- Based on Ethernet
- Many-to-many configuration
- Low latency
- Mix and match high BW Gbps with low BW 100Mbps
- IEEE 802.1BA: Audio Video Bridging (AVB) Systems
- IEEE 802.1AS: Timing and Synchronization for Time-Sensitive Applications (gPTP)
- IEEE 802.1Qat: Stream Reservation Protocol (SRP)
- IEEE 802.1Qav: Forwarding and Queuing for Time-Sensitive Streams (FQTSS)

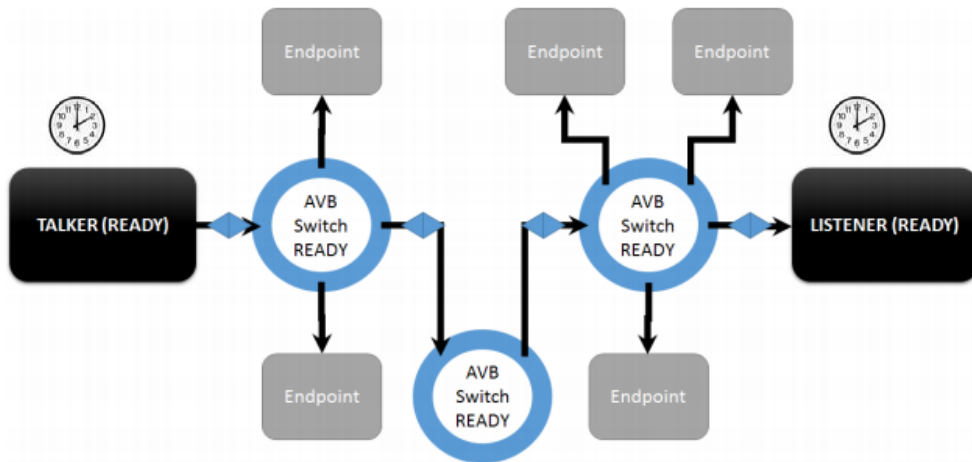
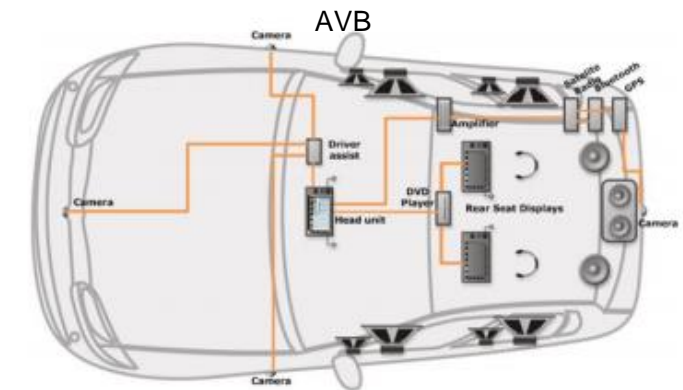
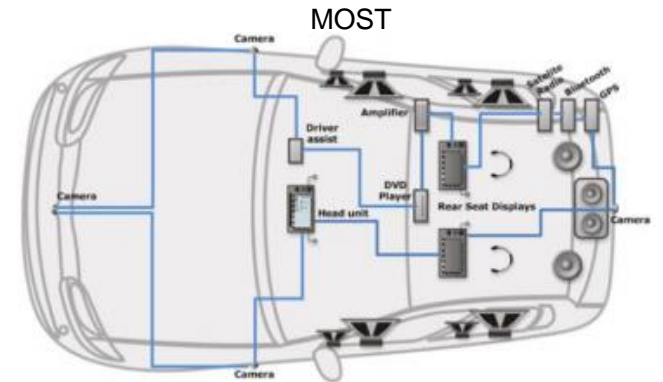
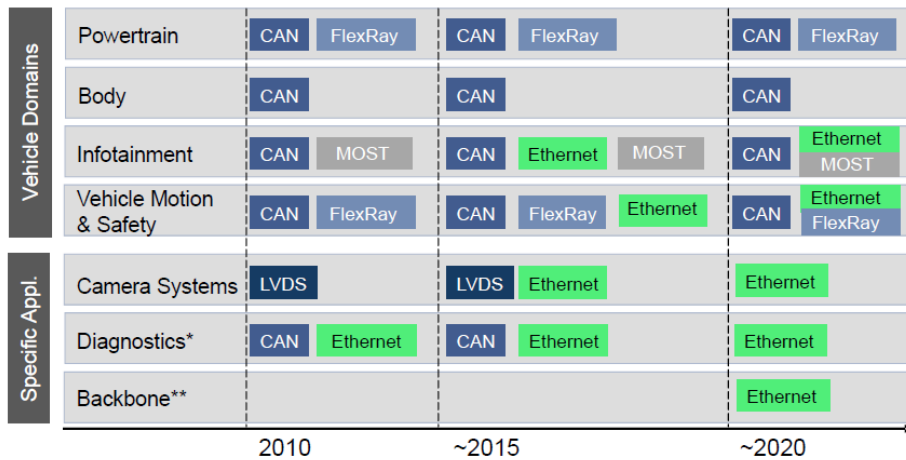

Figure 10: Step 2 for Stream Reservation Protocol



Replaced by Ethernet?



Source: Bosch

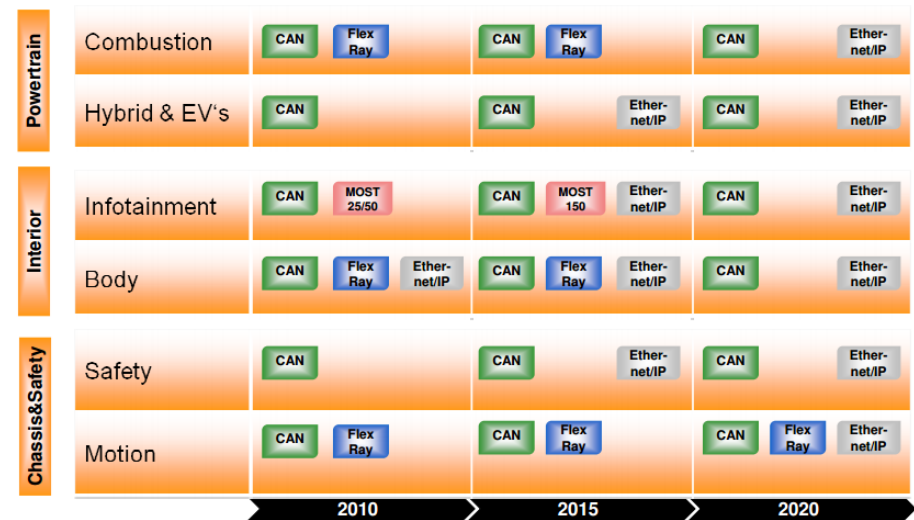

Source: Continental

Coming up next for Automotive Ethernet... 1000Base-T1

- Standard: IEEE 802.3bp (Approved on June 30 2016)
- Higher bandwidth: uncompressed video needs 200 – 800Mbps
- Single twisted pair copper cable

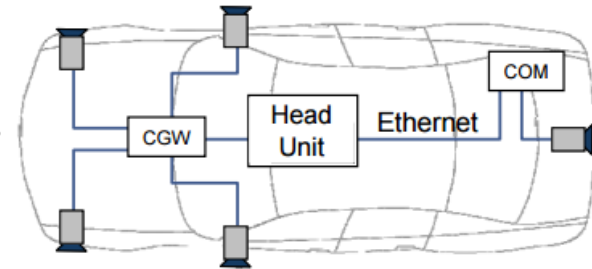

CGW = Camera Gateway

Driver assist system

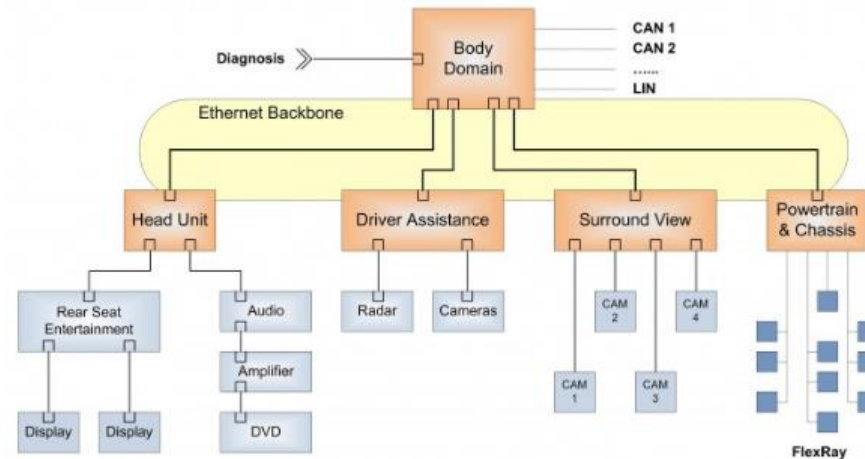
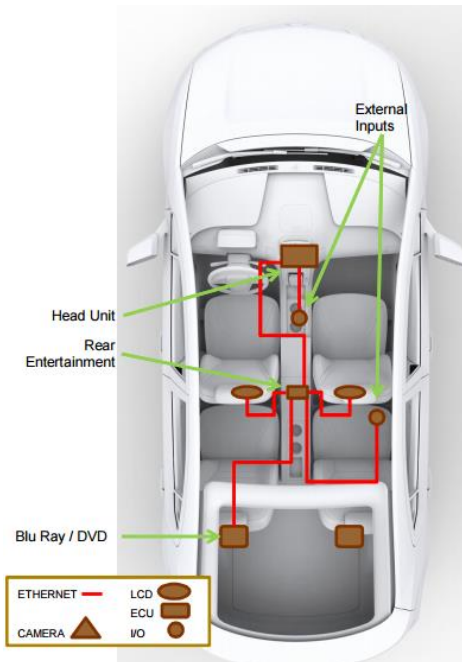

Ethernet backbone

Table of Content

- Automotive Market Trend
- Different types of communication
- **Keysight Solutions for Automotive Communication Test**
 - **CAN, LIN, SENT, CXPI, FlexRay, LVDS, BroadR-Reach**
 - **CAN, CANFD, CANdbc labs, SENT/CXPI examples**
- Probing requirements
- High Speed Digital Application for Automotive
 - USB solution
 - DDR solution

CAN Triggering and Analysis

DSOX3AUTO, DSOX4AUTO, DSOX6AUTO

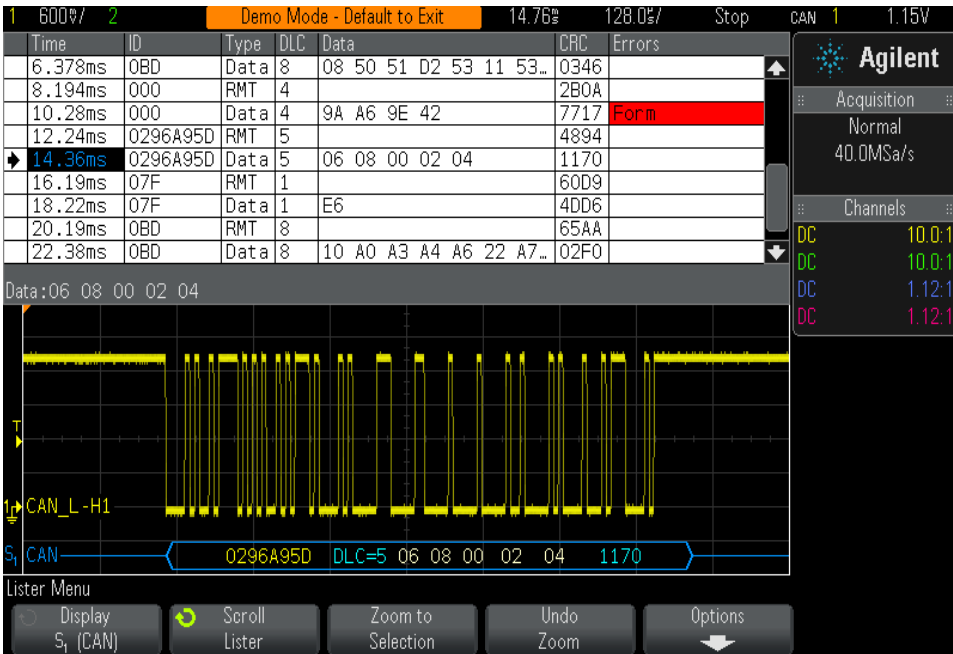

- **Controller Area Network**
- **Signals: 2-wire differential with embedded clock**
 - ✓ Multi-node, asynchronous clocking, event-driven with arbitration
- Primary application: Automotive, industrial automation, medical
- Baud rate: Up to 1 Mb/s
- Encoding: NRZ with bit stuffing

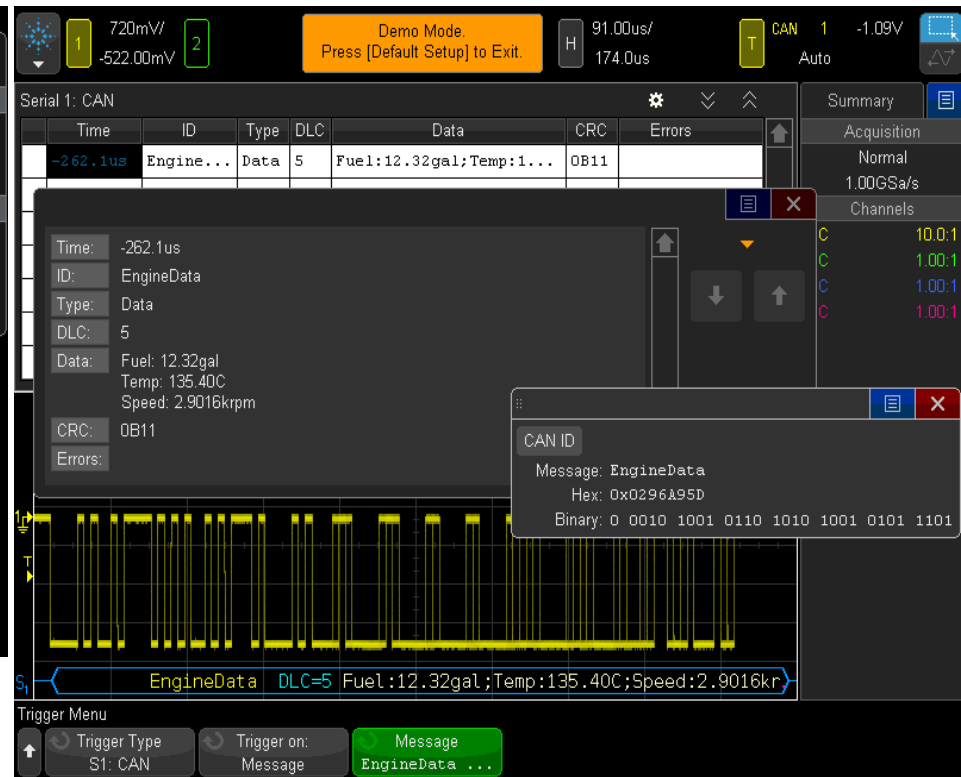

CAN-dbc Symbolic-level Decode & Triggering

CAN Arbitration

Non-destructive bitwise arbitration

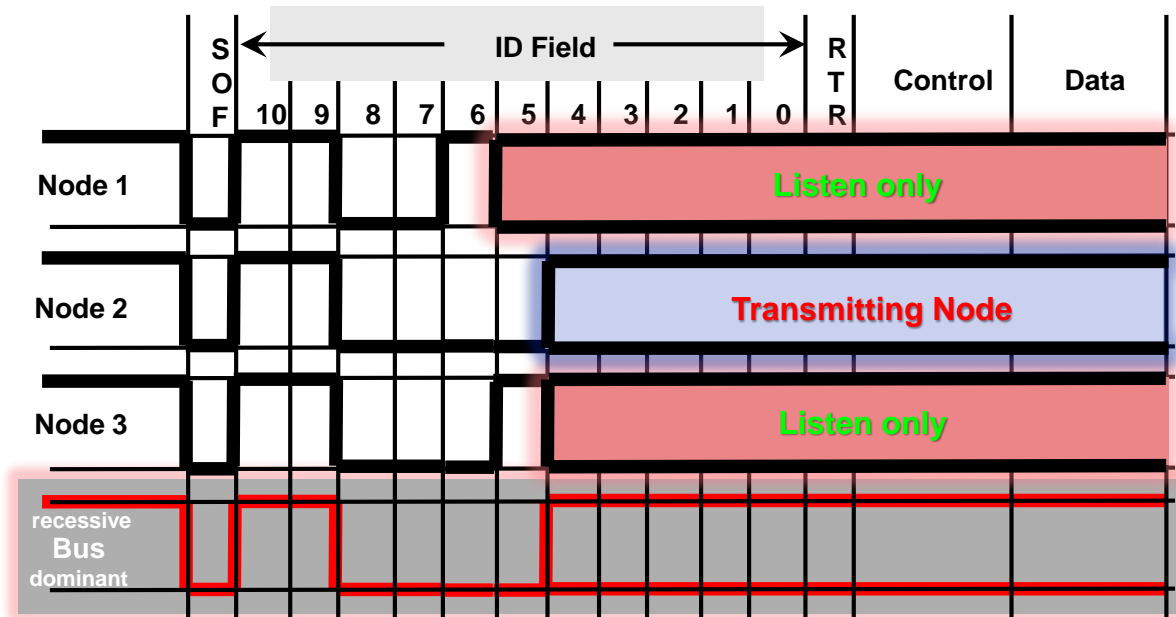

CAN Eye Diagram

Network timing budget

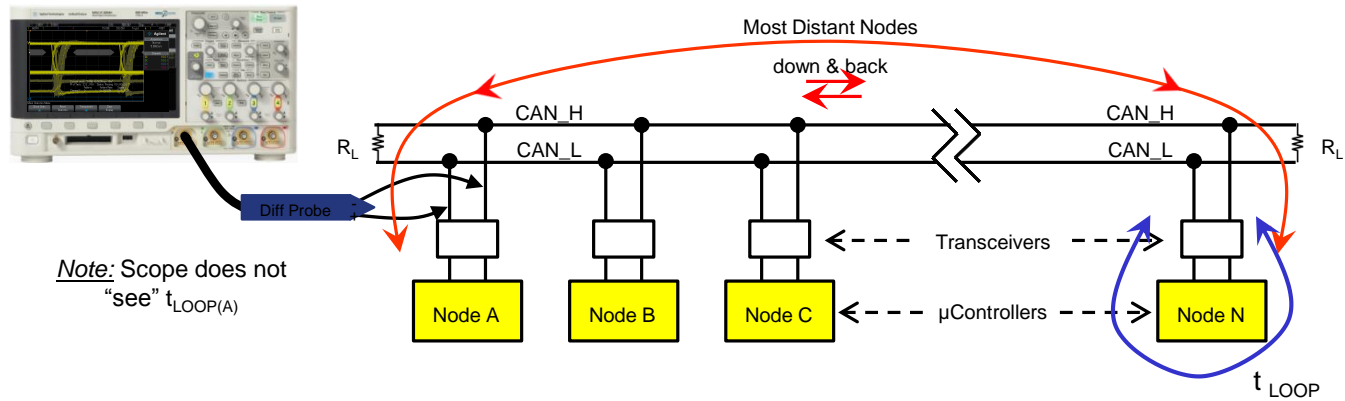

$$\begin{aligned}
 t_{PROP} &= t_{XCVR} + t_{BUS} + t_{XCVR} + t_{CONTROLLER} && \leftarrow \text{down} \\
 &+ t_{XCVR} + t_{BUS} + t_{XCVR} + t_{CONTROLLER} && \leftarrow \text{back} \\
 &= 4 \times t_{XCVR} + 2 \times t_{CONTROLLER} + 2 \times t_{BUS}
 \end{aligned}$$

$$t_{LOOP} = 2 \times t_{XCVR} + t_{CONTROLLER}$$



$$t_{PROP} = 2 \times (t_{LOOP} + t_{BUS})$$

$$t_{BUS} = 5 \text{ ns/meter (typical)}$$

CAN Eye Diagram

Relationship between clock and bit period

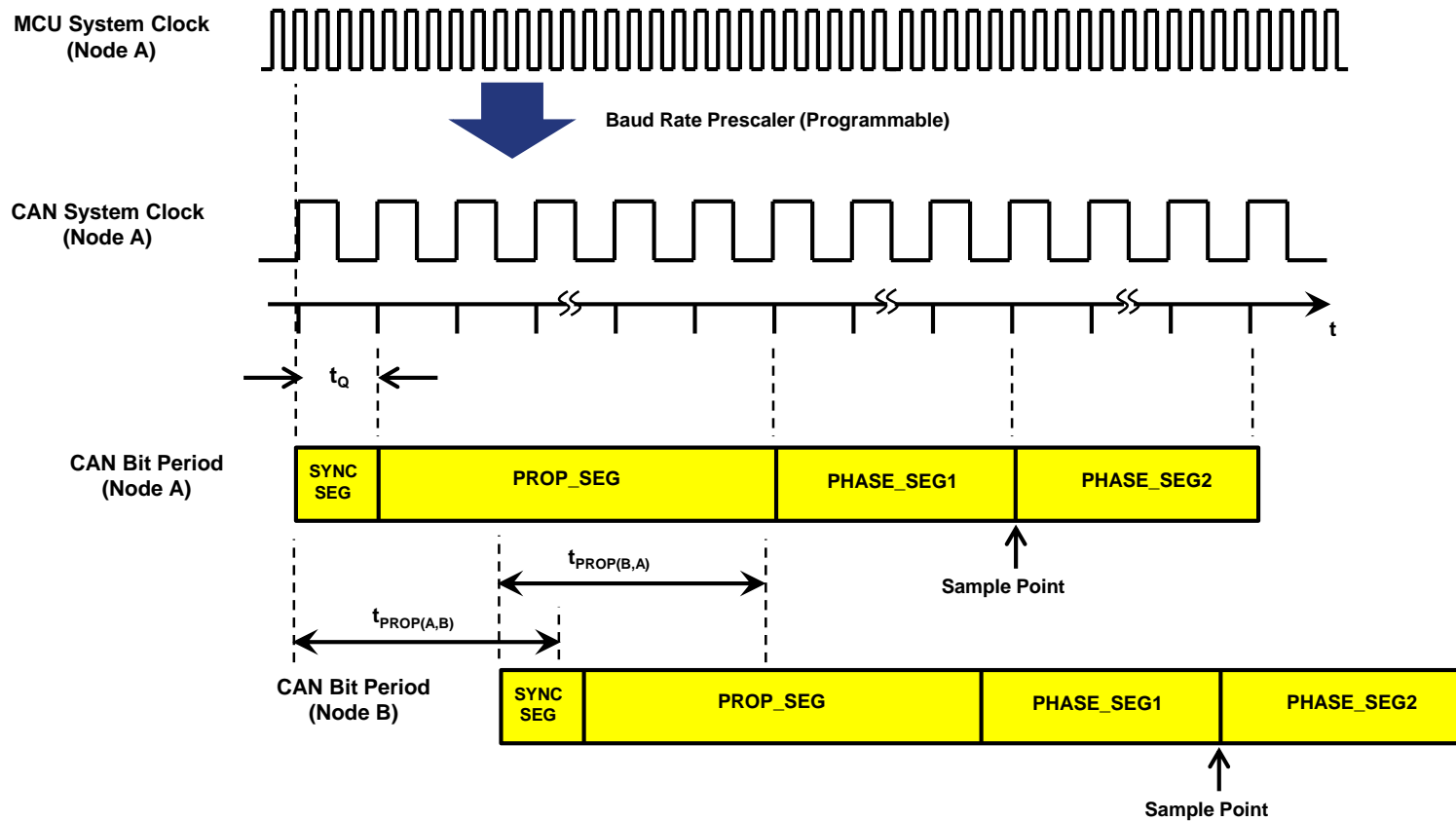

CAN Eye Diagram

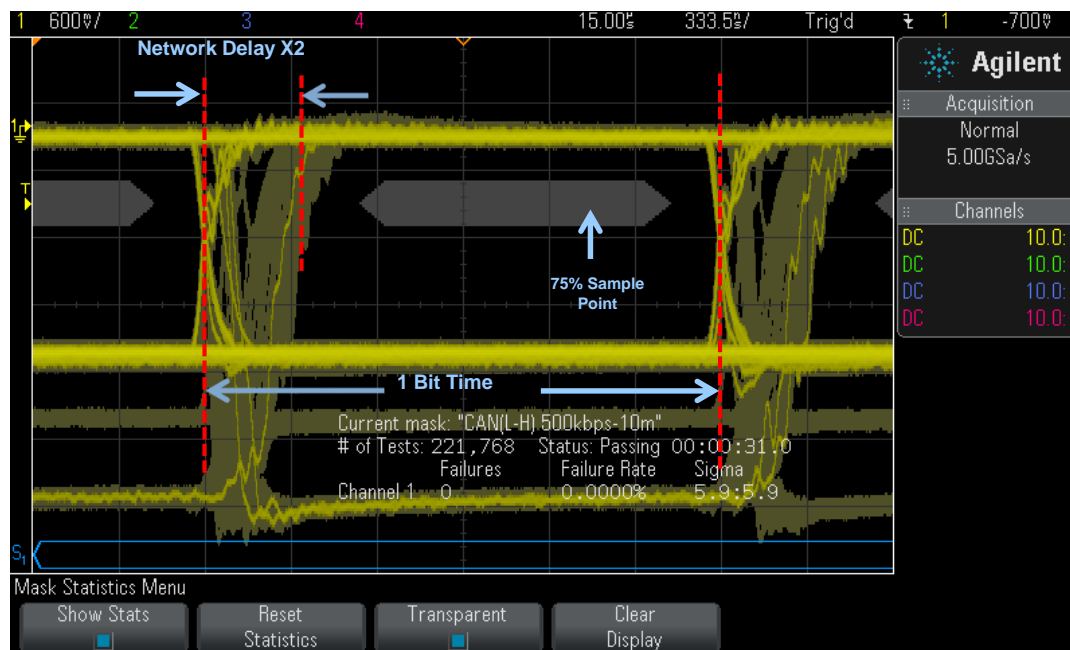

500 kbps CAN-Diff (dominate-bit low)

- Composite CAN physical layer signal integrity test
- Unique scope clock recovery/synchronization algorithm
- Shows worst-case amplitude variations
- Show worst-case timing uncertainties and errors (dominated by network delays)

NEW! CAN-FD Triggering and Analysis

DSOX3AUTO, DSOX4AUTO

CAN FD is the next-generation, higher-performance serial bus protocol for automotive control and diagnostic applications. With “classic” CAN 2.0, transmission rates are limited to 1 Mbps because of the event-driven nature of this serial bus. With CAN FD, transmission rates increase during the data phase of each frame and maximum specified payload sizes are increased from 8 bytes up to 64 bytes.

Transitioning from CAN 2.0 to CAN FD technology is an easier and more seamless migration path for automotive engineers that need to reduce bus loads and increase throughput for today’s more demanding automotive applications versus adopting other synchronous bus serial protocols such as FlexRay.

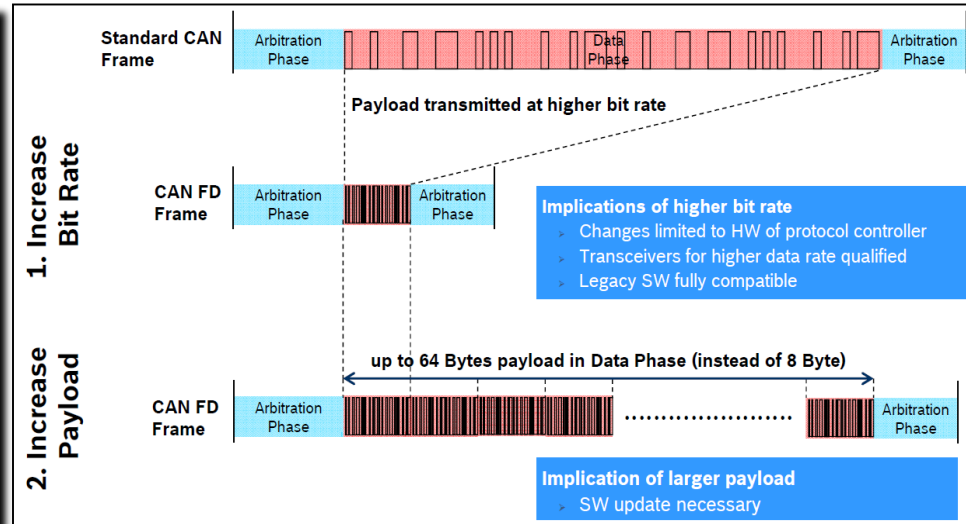
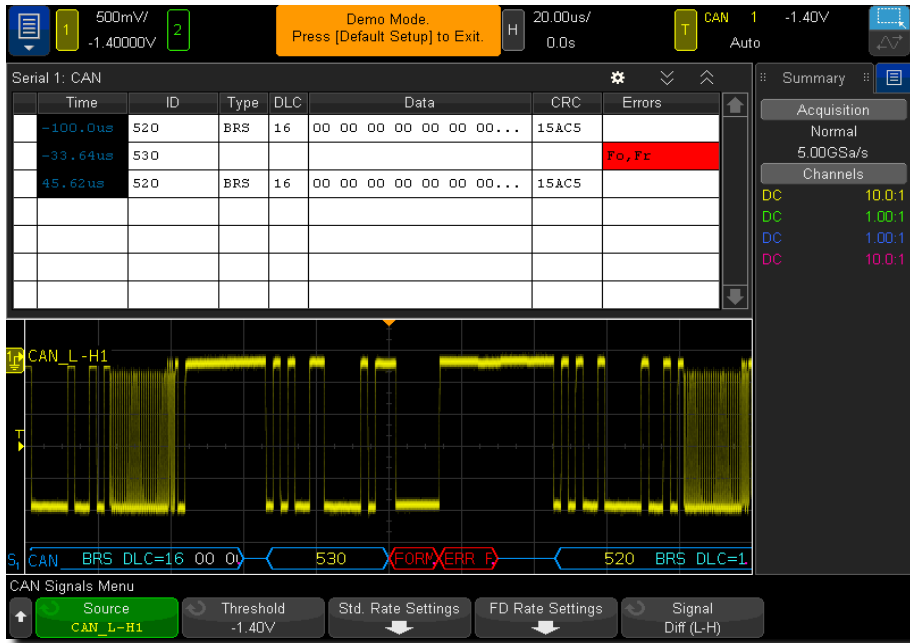

Unchanged

- Arbitration
- Acknowledge mechanism
- NRZ Encoding
- Differential
- Bus Topology

LIN Triggering and Decoding

DSOX3AUTO, DSOX4AUTO, DSOX6AUTO

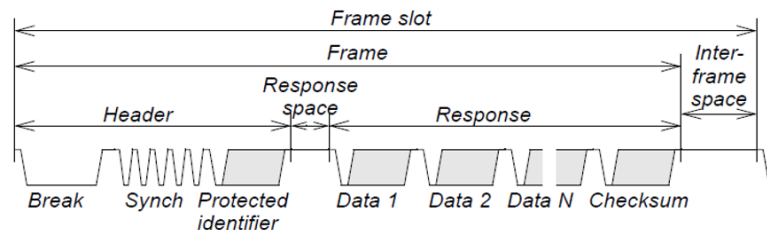

The structure of a LIN 2.0 frame

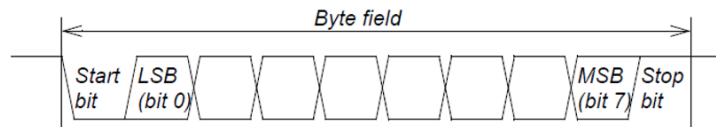

The structure of a byte field

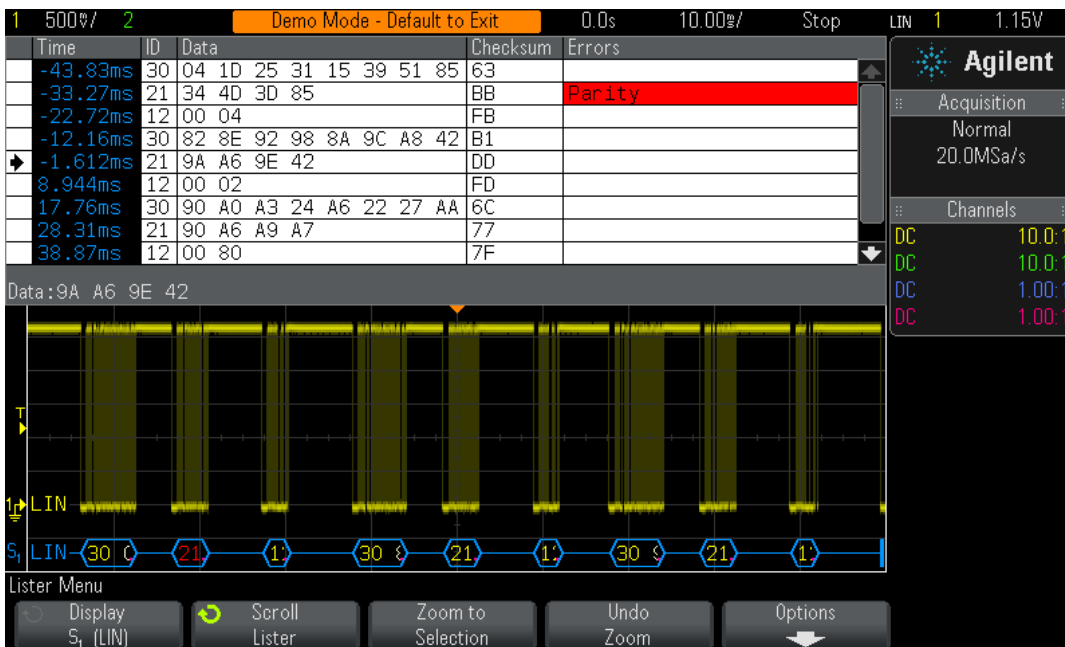

- Local Interconnect Network
- Signals: 1-wire, single-ended, with embedded clock
- Master/Slave relationship
- Primary application: **Non-safety-critical automotive** (windows, lock, etc.)
- Baud rate: Up to 625 kb/s

FlexRay Triggering and Analysis

DSOX3FLEX, DSOX4FLEX, DSOX6FLEX, N5432C, N8803C (Infiniium)

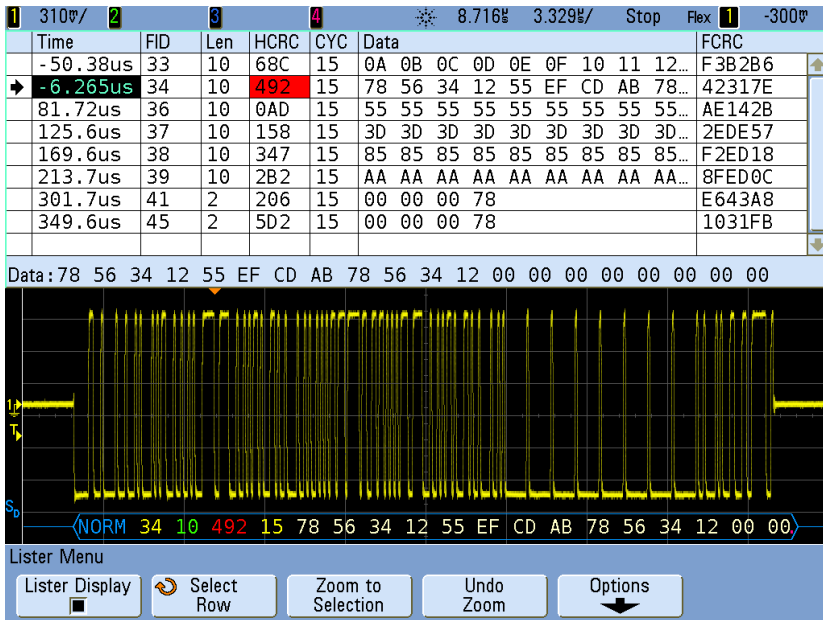

FlexRay Physical Layer Conformance Test App

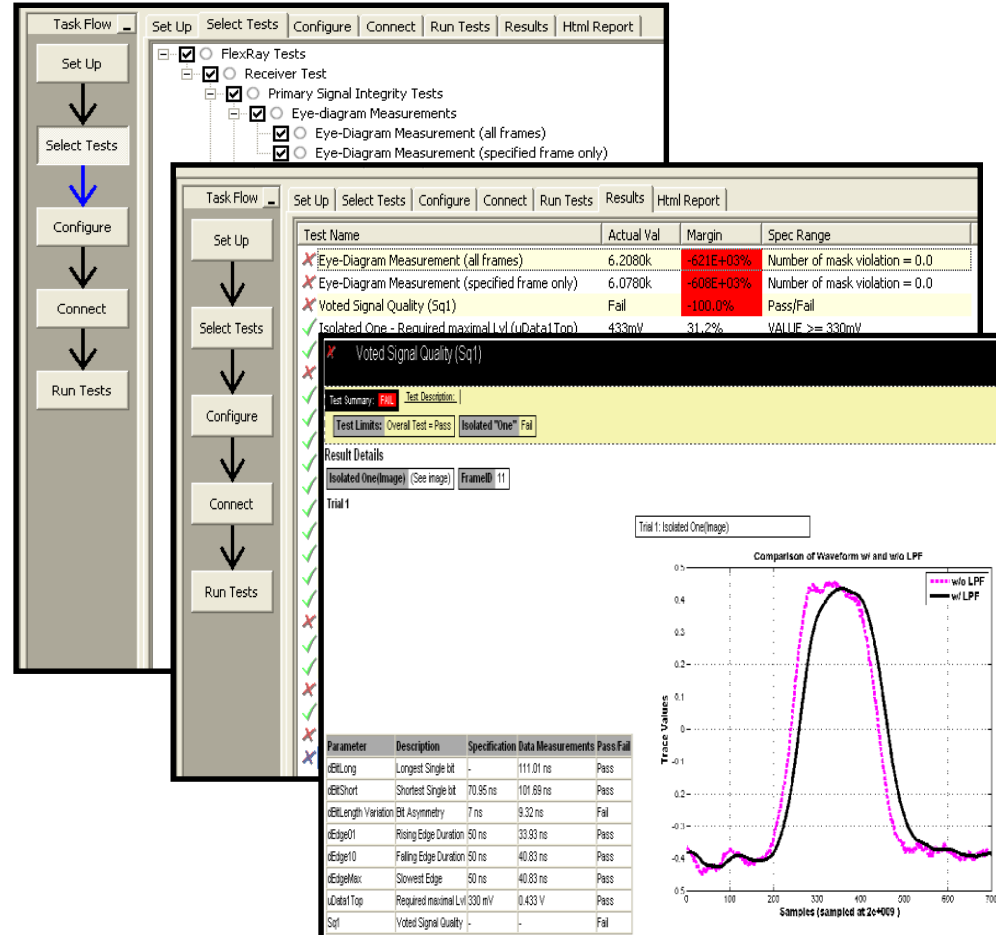

- Signals: 2-wire, differential, with embedded clock
- Primary application: **safety-critical automotive (drive-by-wire)**
- Baud rate: Up to 10 Mb/s
- Protocol: NRZ, multi-node synchronous bus/time-division-multiple-access (TDMA)

SENT Triggers and Analysis

DSEX4SENSOR, DSEX7SENSOR, DSEX10SENSOR

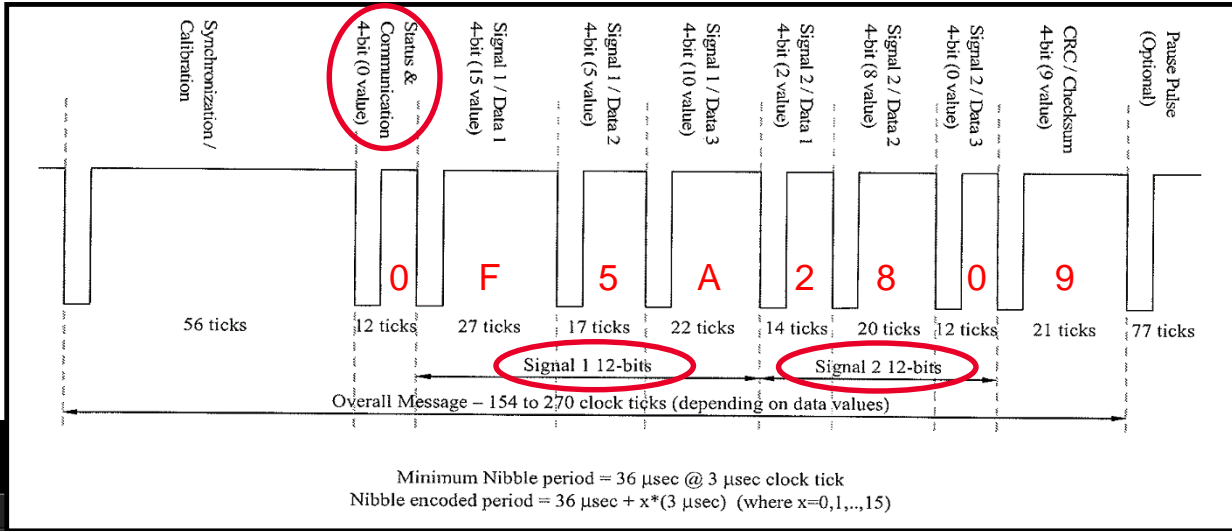

550mV / 1.10000V

Serial 1: SENT

| Time | S&C | ID | Data | CRC | Errors |
|----------|------|----|---------------------|-----|--------|
| ? | | | S2:1.000 | 5 | |
| -49.49ms | 1100 | | S1:2.333k; S2:0.0 | 6 | |
| -48.55ms | 1100 | | S1:0.0; S2:0.0 | 5 | |
| ? | | 96 | AD7 | 37 | |
| -47.62ms | 0100 | | S1:1.342k; S2:0.0 | F | |
| -46.68ms | 0000 | | S1:1.864k; S2:1.000 | 3 | |
| -45.74ms | 1100 | | S1:1.196k; S2:0.0 | A | |

Acquisition: Normal, 10.0MSa/s

Channels: DC 100:1, DC 1.00:1, DC 1.00:1, DC 100:1

Message Format: Fast + Enhanced Serial

Message Format: Fast+Enhanced

- **Single Edge Nibble Transmission**
- Signaling: Single-ended (referenced to ground)
- Primary application: Serially transmits **automotive analog sensor data** to ECUs
- Minimum “tick” time: 3 μs
- Encoding: Pulse-width modulation by nibble (12 ticks = 0, 27 ticks = F)

NEW!

CXPI Triggering and Analysis

DSOX4CXPI, DSOXT3CXPI



- Clock Extension Peripheral Interface
- Signaling: Single-ended (referenced to ground)
- Primary application: Serially transmits automotive analog sensor data to ECUs
- Minimum “tick” time: 3 μ s
- Encoding: Pulse-width modulation by nibble (12 ticks = 0, 27 ticks = F)

MOST Compliance Application Software

N6466A / N6466B

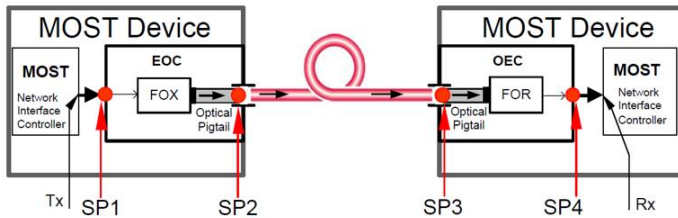

ex. MOST150 oPHY Testing

- Media Oriented Systems Transport
- Supports MOST50 and MOST150 (cPhy and oPhy)
- 100% compliance test coverage for all tests
- MOST50 compliance testing requires Infiniium oscilloscopes with 500 MHz or greater bandwidth.
- MOST150 compliance testing requires Infiniium oscilloscopes with 1 GHz or greater bandwidth.
- While the MOST150 cPhy compliance tests use a differential probe (1.5 GHz or higher)

| Test Name | Actual Val | Margin | Pass Limits |
|-----------------------------|----------------|--------|-------------------------|
| ✓ Transferred Jitter - Jtr1 | 13.494ps | 73.0% | VALUE <= 50.000ps |
| ✓ Eye Mask - A1..H1 | OUI Violations | 0.0% | VALUE <= OUI Violations |
| ✓ Rise time - tr2 | 1.133280ns | 33.1% | VALUE <= RiseFallLimits |
| ✓ Fall time - tf2 | 1.145810ns | 32.4% | VALUE <= RiseFallLimits |
| ✓ Transferred Jitter - Jtr2 | 13.494ps | 88.0% | VALUE <= 112.000ps |

| Parameter | Value |
|--------------------|-------------------|
| Pass Limits | <= OUI Violations |
| Parameter Tested | Eye Mask A4..H4 |
| Actual Value | OUI Violations |
| Referenced Values: | |
| Bit Time | 3.3890247E-09 |
| Waveform Src | CHANnel1 |

BroadR-Reach Compliance Application

N6467A, N6467B

TWISTED-PAIR
ETHERNET

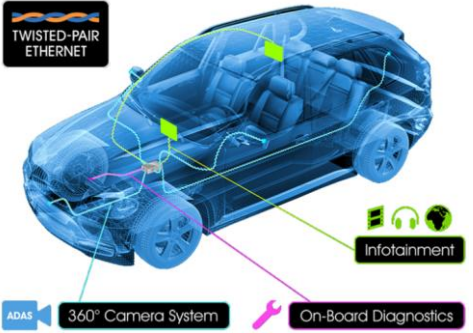

| | 100bT Ethernet | BroadR-Reach |
|--------------------------|----------------------|-----------------------|
| Differential pairs | 2 | 1 |
| Connector | RJ-45 | user selects |
| Frequency | 80 MHz | 66.3 MHz |
| Signal levels | multiple | PAM3 ended (high-low) |
| Bit rate | 100 Mb/s | 100 Mb/s |
| Termination | 100 Ω | 100 Ω |
| Compliance test stimulus | SW generated traffic | SW generated traffic |

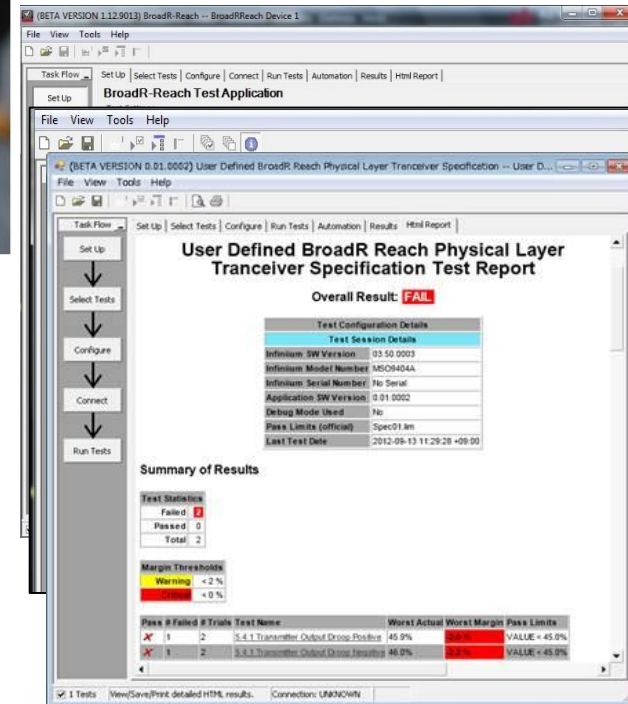
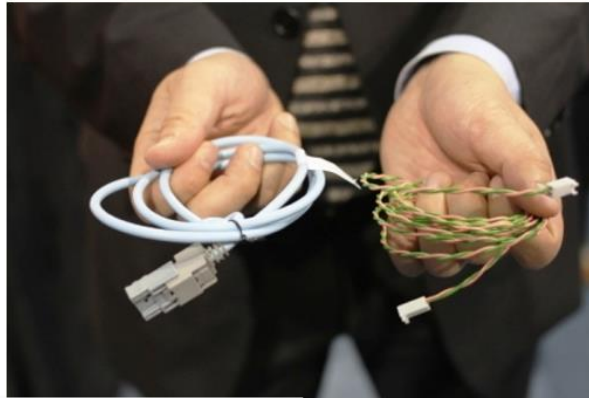

Reduces connectivity costs up to 80%*
Reduces cabling weight up to 30%*

USB Cable from DUT to scope

DSOS9104A 1 GHz or better

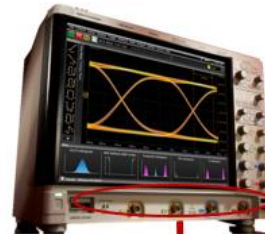

Broadcom DUT



Twisted pair cable from DUT to connector board

BNC Cables from connector board to scope

BroadR-Reach Alliance

OPEN = One Pair Ethernet

100Base-T1 Compliance Testing

Requires Infiniium oscilloscope with 1GHz or greater bandwidth

Probing the differential CAN bus

Requires a differential active probe

Probing to view dominant-bit-high

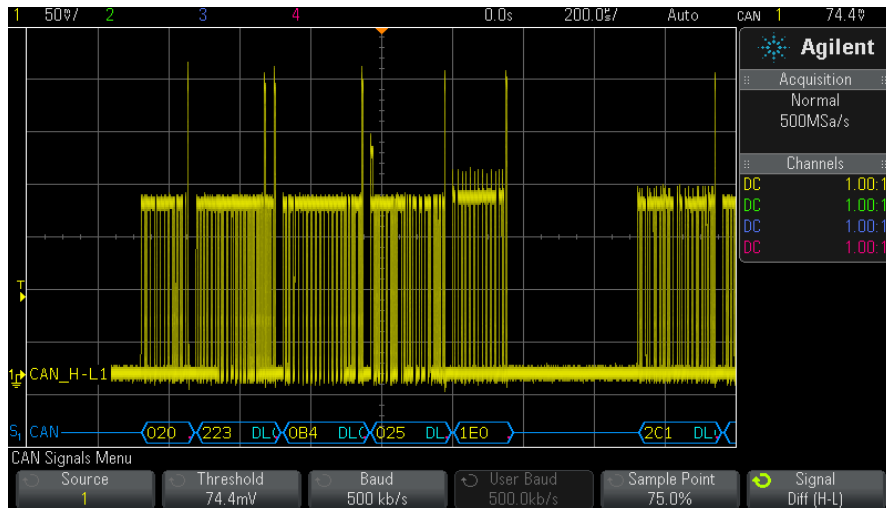

- Connect “+” input of probe to CAN_H
- Connect “-” input of probe to CAN_L
- Idle = Low
- High = Logic 0 = ~+2 V
- Low = Logic 1 = ~0 V

Probing to view dominant-bit-low

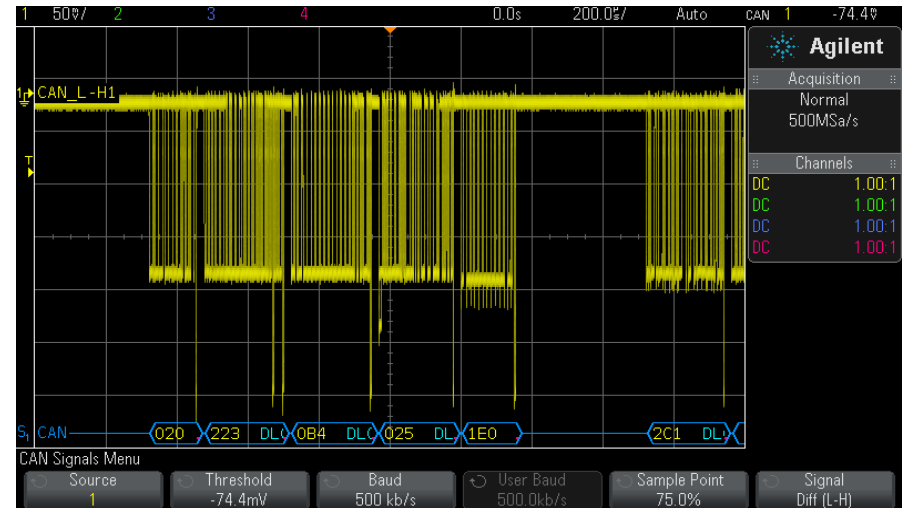

- Connect “+” input of probe to CAN_L
- Connect “-” input of probe to CAN_H
- Idle = High
- High = Logic 1 = ~0 V
- Low = Logic 0 = ~-2 V

Most CAN specification documents show CAN timing diagrams in a dominant-bit-low format.

Identifying when arbitration happens

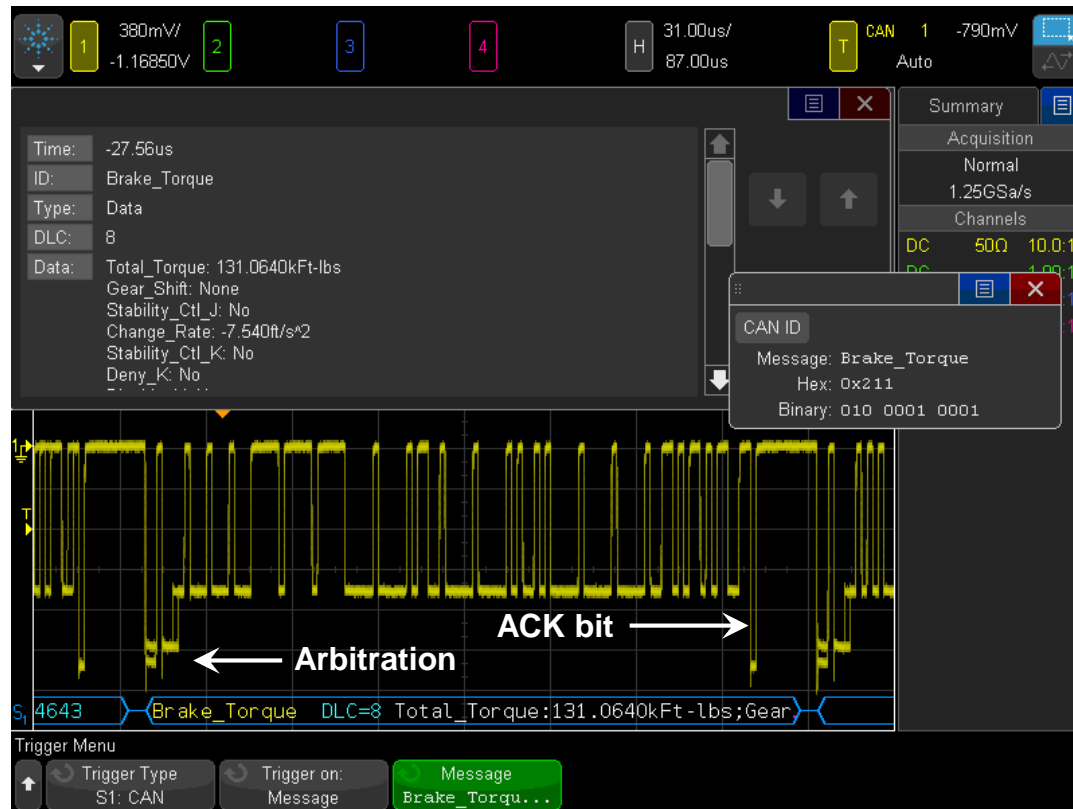

- Identifying infrequent occurrences of arbitration requires a scope with fast update rate and hardware-based decoding to show it.
- When multiple nodes transmit dominant bits, more current flows which drives the bus to a lower low level.

Zooming-in on the beginning of a CAN message

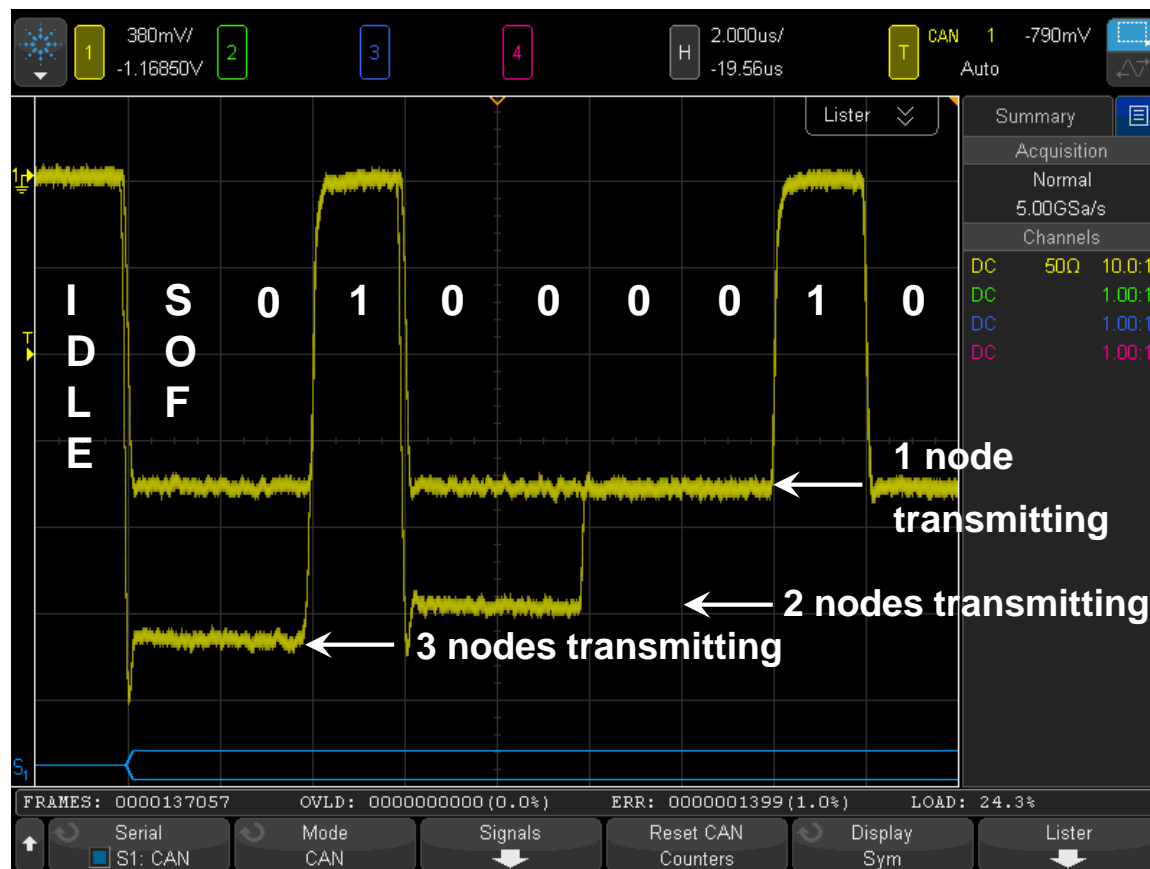

- Repetitive acquisitions
- Brake_Torque = ID: 0x211_(HEX) = 010 0001 0001_(Binary)

Zooming-in on the beginning of a CAN message

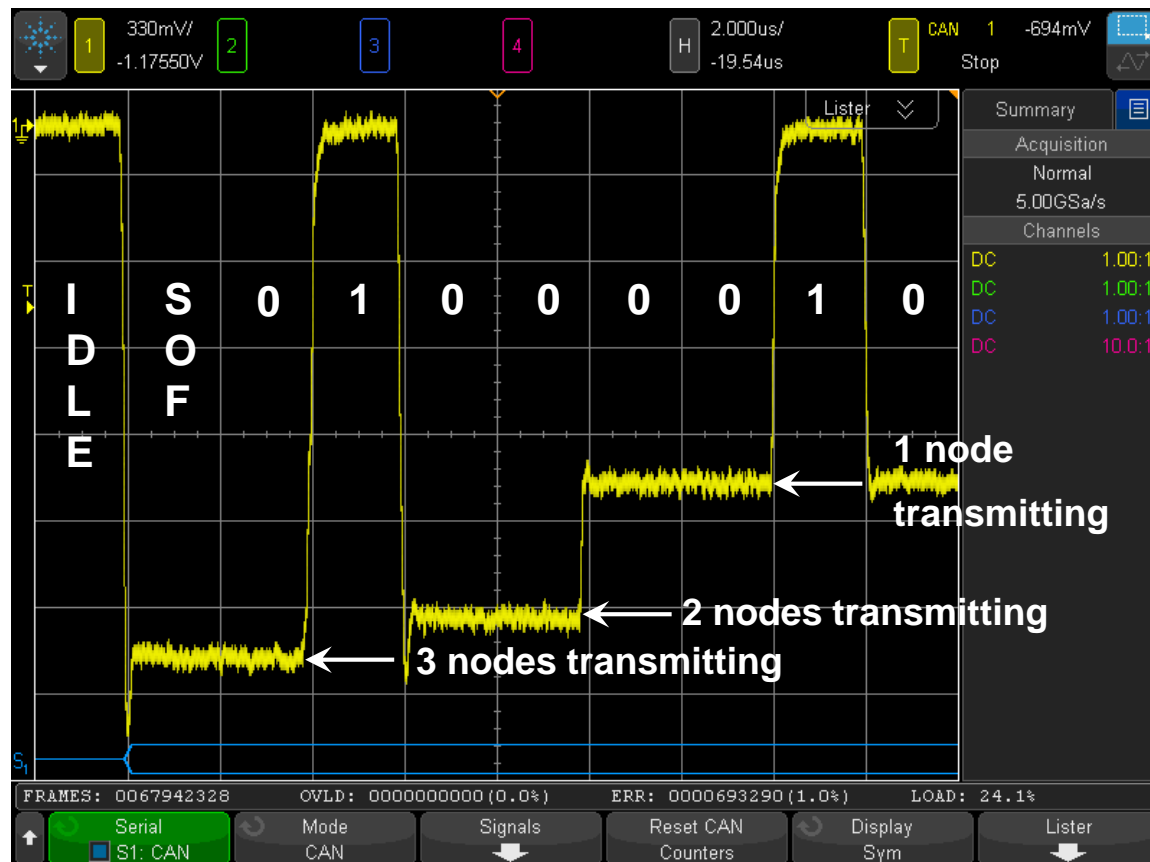

- Single-shot acquisition of one occurrence of arbitration
- Brake_Torque = ID: $0x211_{(HEX)} = 010\ 0001\ 0001_{(Binary)}$

Synchronize on arbitration using *Zone Trigger*

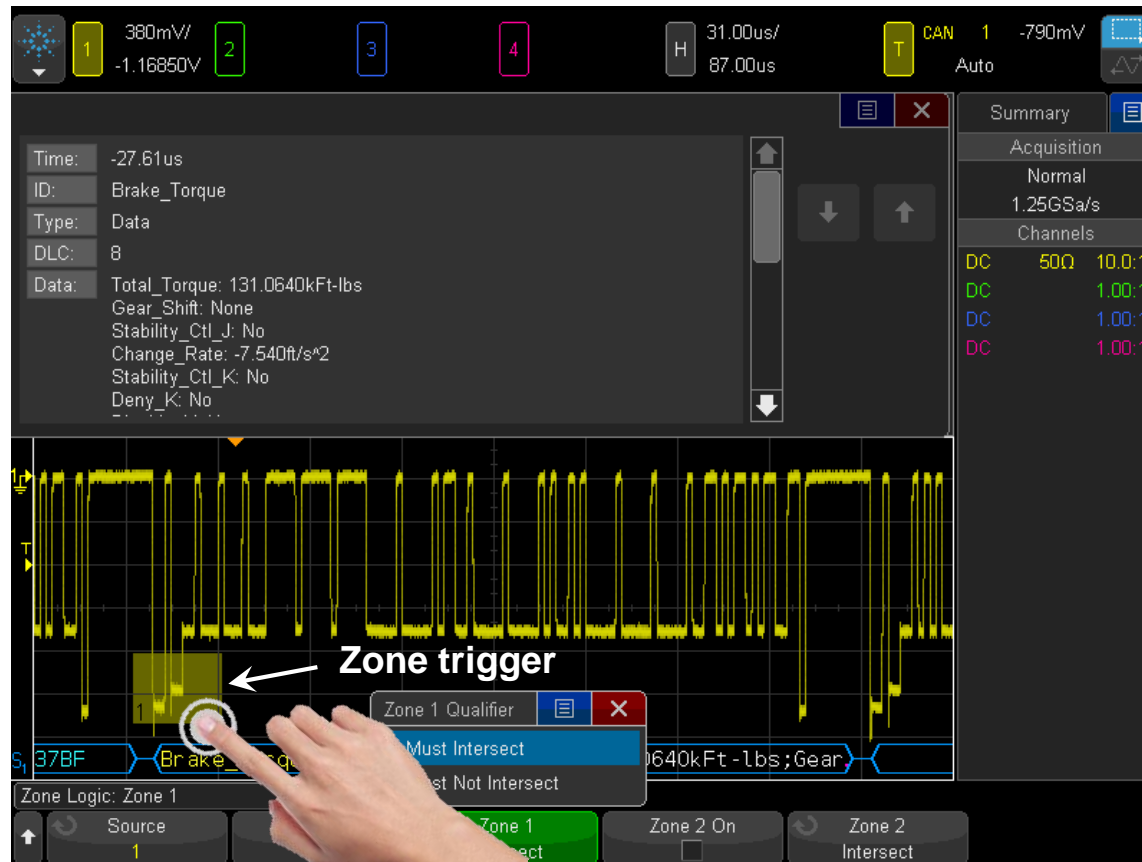

1. Trigger on message name or frame ID.
2. Then qualify triggering on "zone".
3. Scope locks-in on message only if arbitration occurs.

Tradition Deep Memory Acquisition

Acquisition Time = Memory Depth/Sample Rate

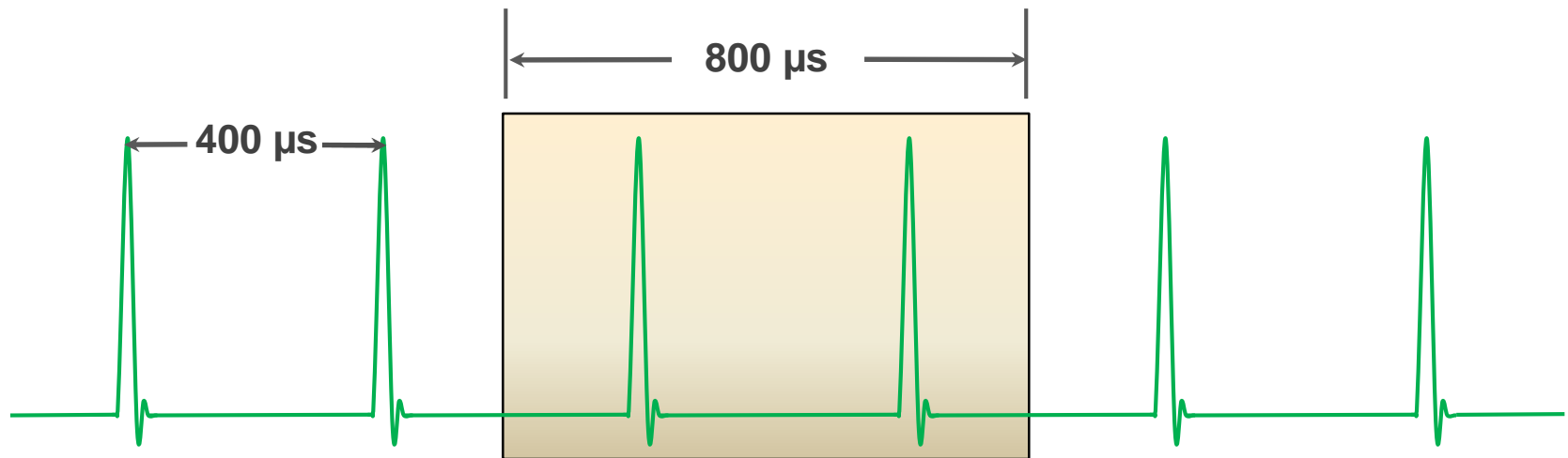

MSO4000X Example:

Max Sample Rate = 5 GSa/s

Max Memory = 4 MegaBytes

Max Acquisition Time = 800 μs

Max Pulses = 2

Segmented Memory Acquisition

Selectively captures more waveform data with precise time-stamps for each segment

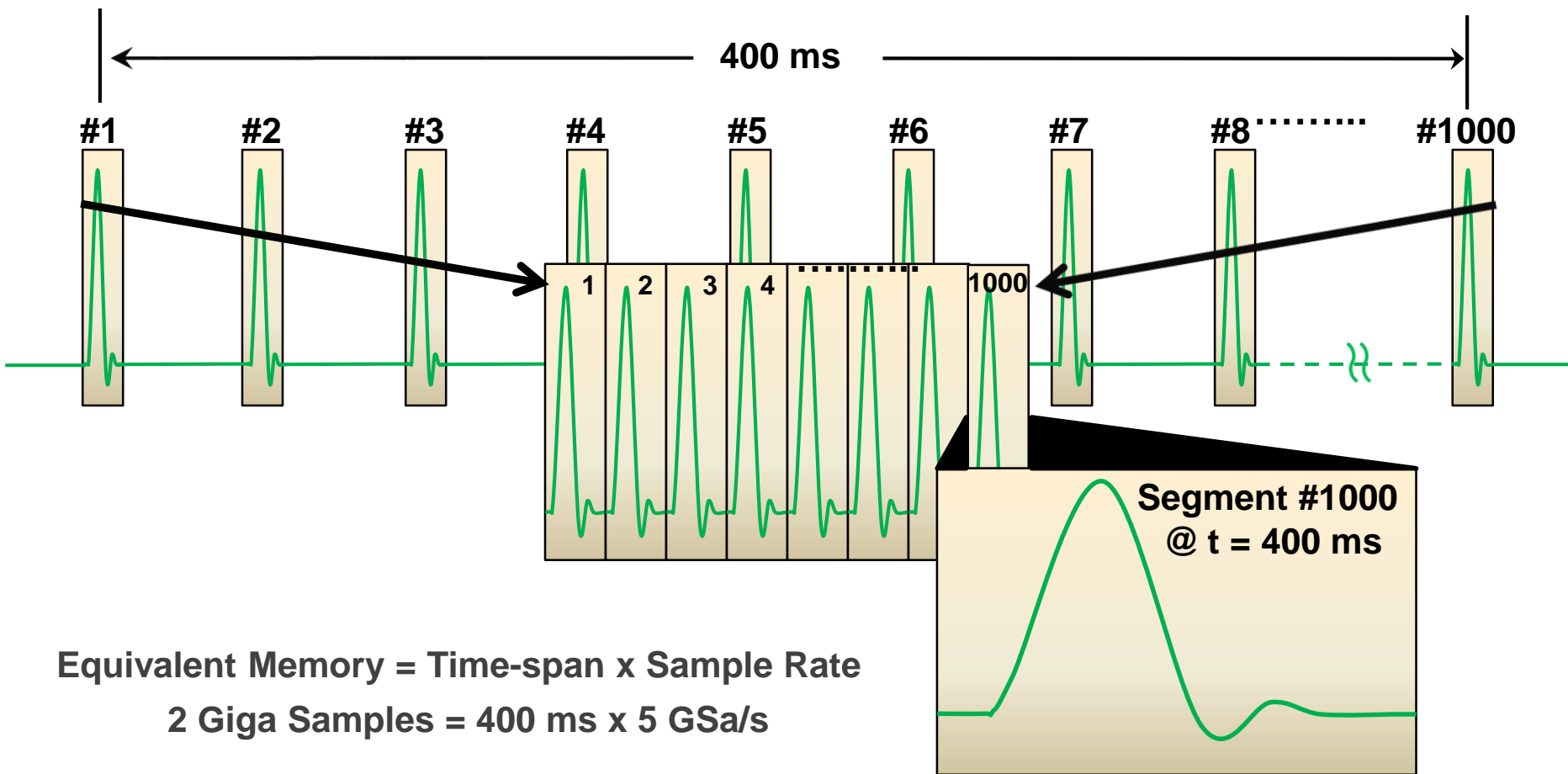

Equivalent Memory = Time-span x Sample Rate
2 Giga Samples = 400 ms x 5 GSa/s

Characterizing arbitration frequency-of-occurrence

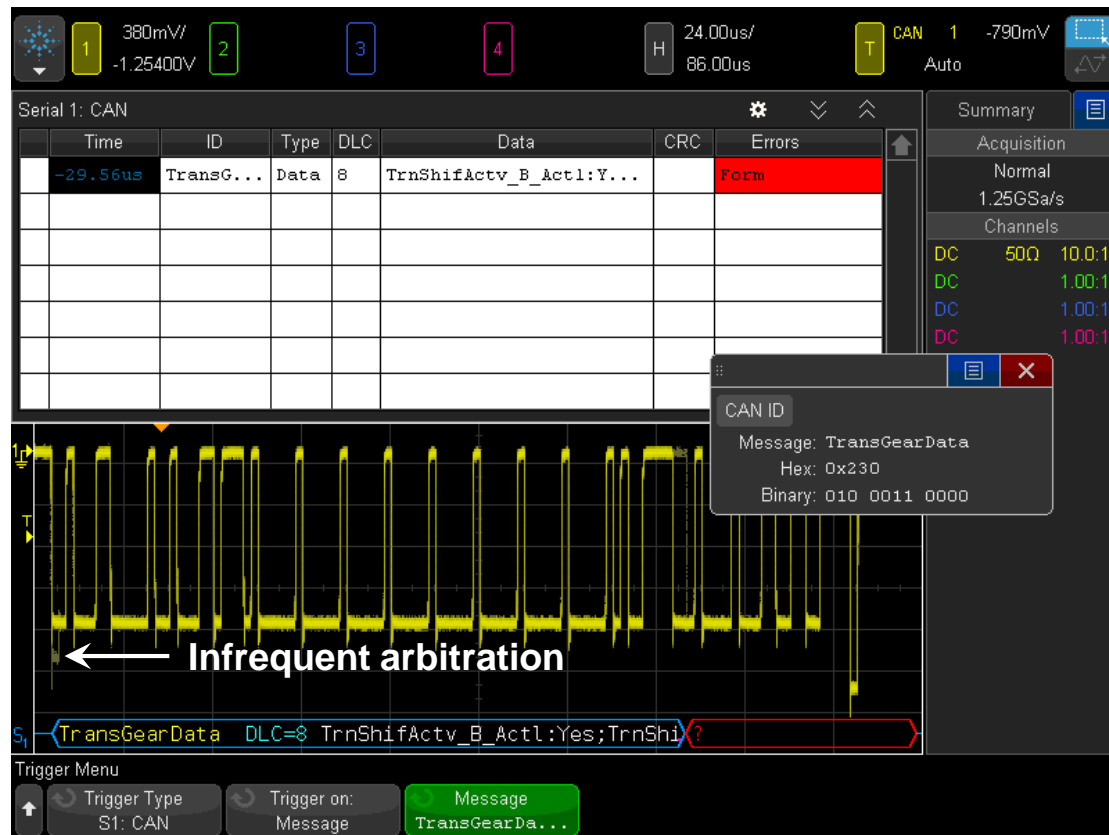

Step #1: Trigger on message name or frame ID.

For this measurement example: Trigger = Message: TransGearData

Step #2: Use Segmented Memory to capture 800 consecutive occurrences of “TransGearData”

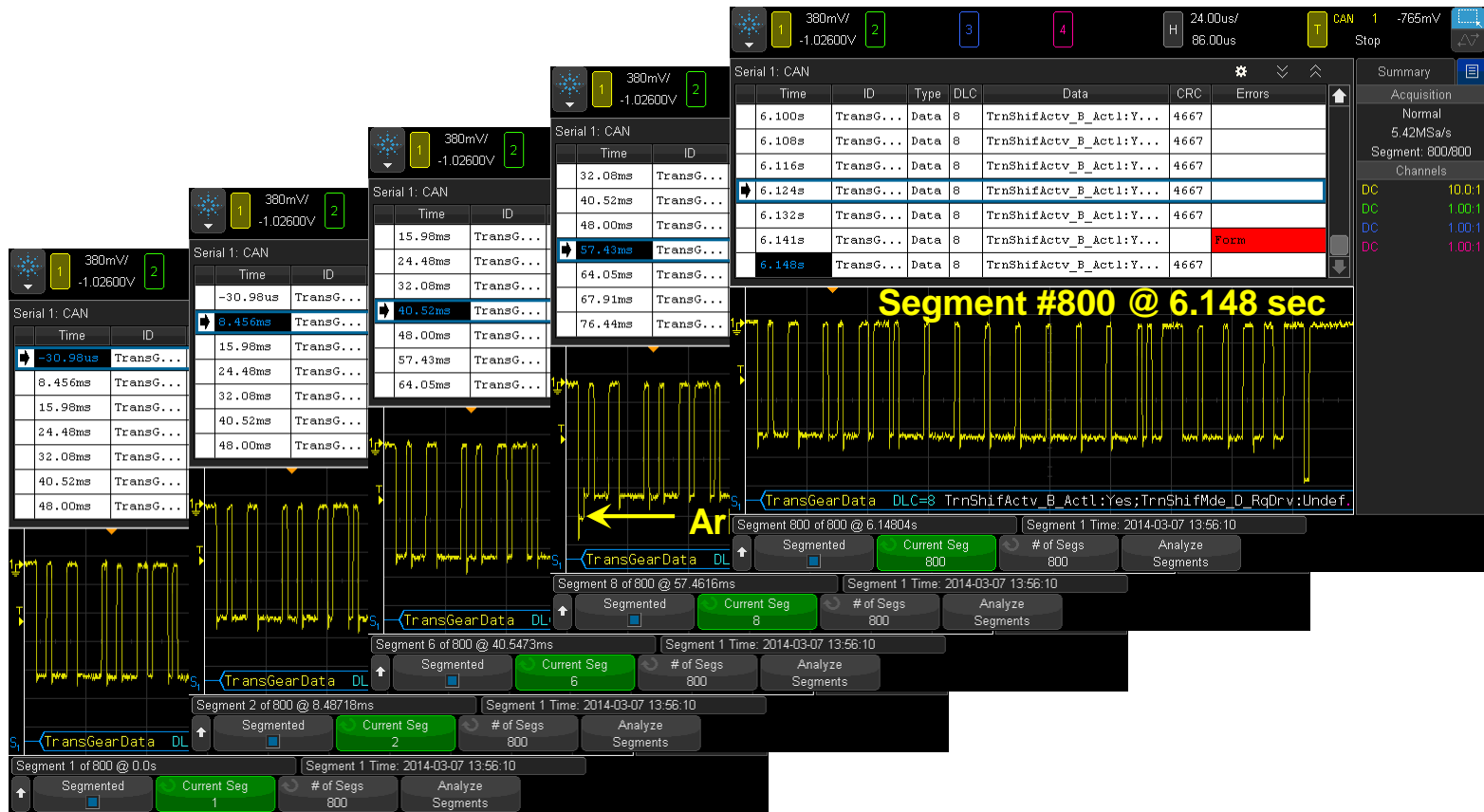

Trigger = Message: “TransGearData” (Frame ID: 230_{HEX})
Total Captured Time-span = 6.148 seconds
Equivalent Memory = 30 M points

Step #2: Add Zone Trigger qualification to capture “TransGearData” , but only when arbitration occurs

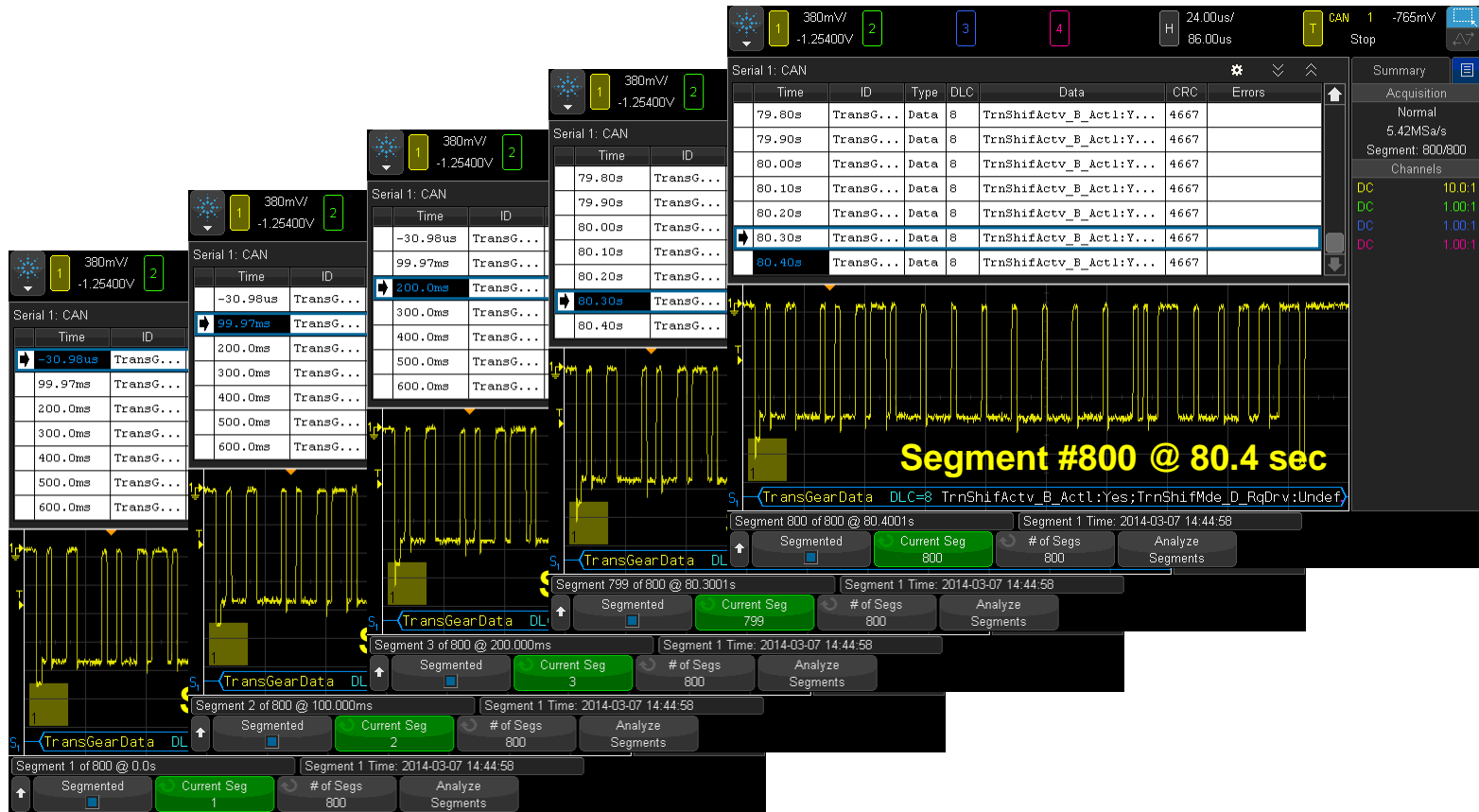

Trigger = Message: “TransGearData” (Frame ID: 230_{HEX}) with Zone Trigger
Total Captured Time-span = 80.4 seconds
Equivalent Memory = 400 M points

Keysight Offering for Automotive Bus

| | InfiniiVision 2000 X | InfiniiVision 3000T X | InfiniiVision 4000 X | InfiniiVision 6000 X | Infiniium S |
|-------------------------------|----------------------|-----------------------|----------------------|----------------------|-------------|
| LIN decode | ● | ● | ● | ● | ● |
| LIN symbolic decode | | ● | ● | ● | ● |
| LIN trigger | ● | ● | ● | ● | ● |
| CAN / CAN-FD decode | ● | ● | ● | ● | ● |
| CAN / CAN-FD symbolic decode | | ● | ● | ● | ● |
| CAN / CAN-FD trigger | ● | ● | ● | ● | ● |
| CAN / CAN-FD eye-diagram mask | ● | ● | ● | ● | ● |
| CXPI decode | | ● | ● | | |
| CXPI trigger | | ● | ● | | |
| SENT decode | | ● | ● | ● | |
| SENT trigger | | ● | ● | ● | |
| FlexRay decode | | ● | ● | ● | ● |
| FlexRay trigger | | ● | ● | ● | ● |
| FlexRay eye-diagram mask | | ● | ● | ● | ● |
| FlexRay compliance | | ● | ● | ● | |
| LVDS verification | | | | ● | ● |
| MOST eye-diagram mask | | | | | ● |
| MOST compliance | | | | | ● |
| 100Base-T1 compliance | | | | | ● |

CAN-FD is not supported by InfiniiVision 2000X

6000X series can support Jitter, can support LVDS, clock recovery

Table of Content

- Automotive Market Trend
- Different types of communication
- Keysight Solutions for Automotive Communication Test
 - CAN, LIN, SENT, CXPI, FlexRay, LVDS, BroadR-Reach
 - CAN, CANFD, CANdbc labs, SENT/CXPI examples
- **Probing requirements**
- High Speed Digital Application for Automotive
 - USB solution
 - DDR solution

Recommended probes for CAN and FlexRay

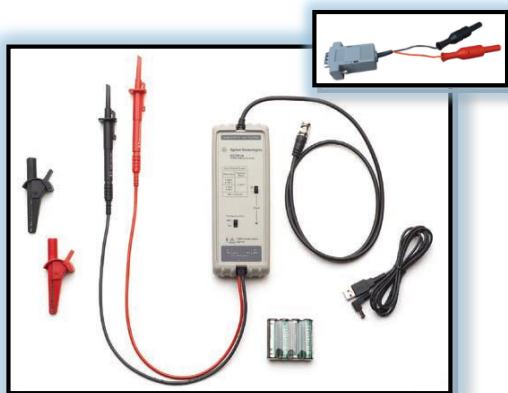

N2791A

Type: Differential active probe
Bandwidth: 25 MHz
Input R: 8 M Ω
Input C: 8 pF
**Interface: Standard BNC w/
manual probe
attenuation settings**
Power: USB cable or battery
**CAN accessory: SubD-DB9
probe head
(0960-2926)**



N2818A

Type: Differential active probe
Bandwidth: 200 MHz
Input R: 1 M Ω
Input C: 3.5 pF
Interface: Keysight AutoProbe
**CAN accessory: SubD-DB9 probe
head (0960-2926)**

Extreme Temperature Probing

For testing in temperatures ranging from -40 to +85°C



N7007A 400 MHz Passive Probe
(2 meters long)



N2797A 1.5-GHz Active Probe
(2 meters long)

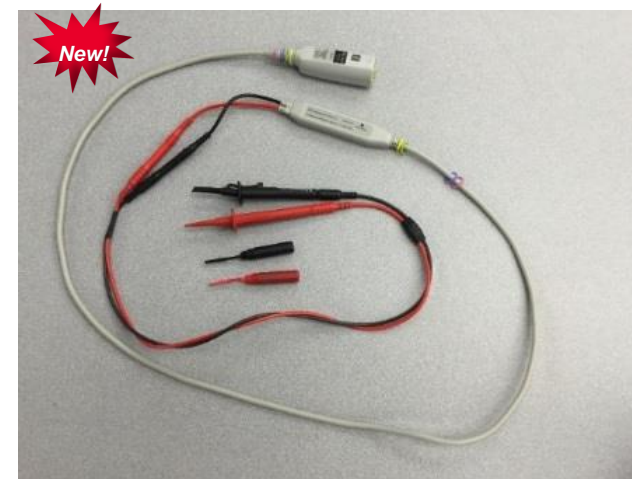

N7013A Differential Probe Extension Cables
(> 2 meters long, 70-MHz BW with N2818A for CAN/CAN FD)

Example of in-vehicle testing







Example of remote in car testing



Table of Content

- Automotive Market Trend
- Different types of communication
- Keysight Solutions for Automotive Communication Test
 - CAN, LIN, SENT, CXPI, FlexRay, LVDS, BroadR-Reach
 - CAN, CANFD, CANdbc labs, SENT/CXPI examples
- Probing requirements
- **High Speed Digital Application for Automotive**
 - **USB solution**
 - DDR solution

High-Speed Digital Markets & Technologies

| | Mobile Digital Video | Computing | Datacenter Cloud | Communications | Aerospace & Defense |
|---------------------------------------|---|---|--|---|---|
| | Front Side Bus Memory Bus I/O | Server Storage LAN | Longhaul, Access, Wireless Backbone | Sat.Comm | |
| |  |  |  |  |  |
| Key Multi-Gigabit Technologies | TBT 3.0 | QPI HT3 | 4x25G 100G Ethernet | OC-768 | |
| | AMB | USB Type-C | 400G Ethernet | XFP | Sat.Comm |
| | 6G/C-PHY MIPI | 28G Fibre Channel | | | |
| | DP 10G USB 3.1 | SATA | 24G SAS | 28-56G CEI | |
| | HDMI SD UHS-II | 16G PCI Express | | PON | |

Hot spots:

- **“Generation 4”** computer buses coming (PCIe4, USB3 10G)
- Investments shift towards **mobile** computing (USB Type-C, MIPI)
- Web traffic increase drives **datacenter** built-out (100GbE & 400 GbE)

USB Evolution

USB 2.0 (2000)

- 480 Mb/s (high-speed)
- 1 bi-directional link
- 4 signals
(D+, D-, V_{BUS}, GND)

USB 3.0 (2008)

- 5 Gb/s
- 8B/10B coded
- +2 new Tx/Rx pairs
- 2.0 backward compatible

USB 3.1 (2013)

- 10 Gb/s
- 128B/132B coded
- 2.0 and 3.0 backward compatible

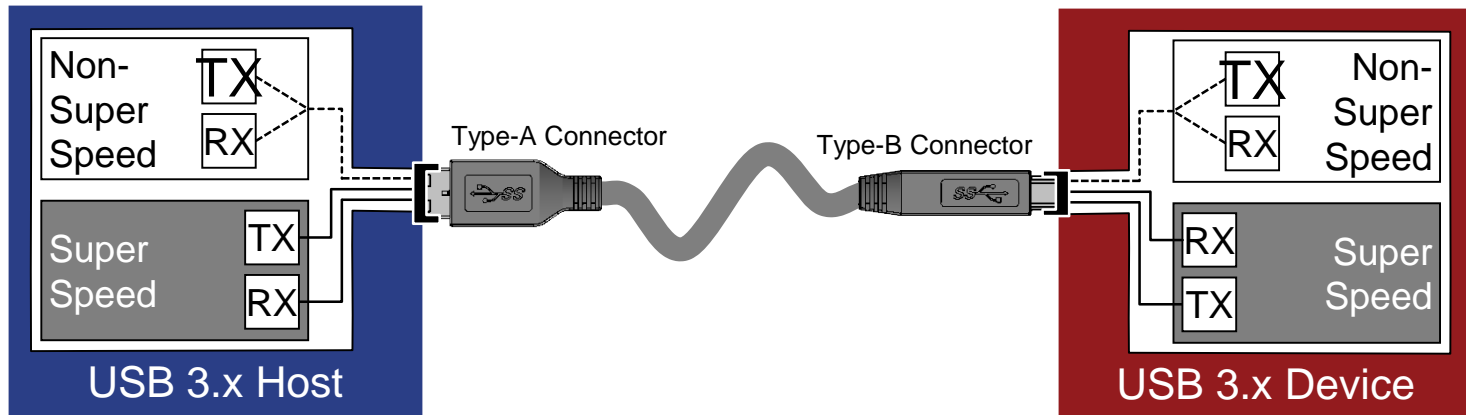

Industry Drivers for Type C

- Eliminate form factor orientation dependency
- Establishes power delivery and charging infrastructure
- Enables infrastructure for adoption by other standards (i.e. video)

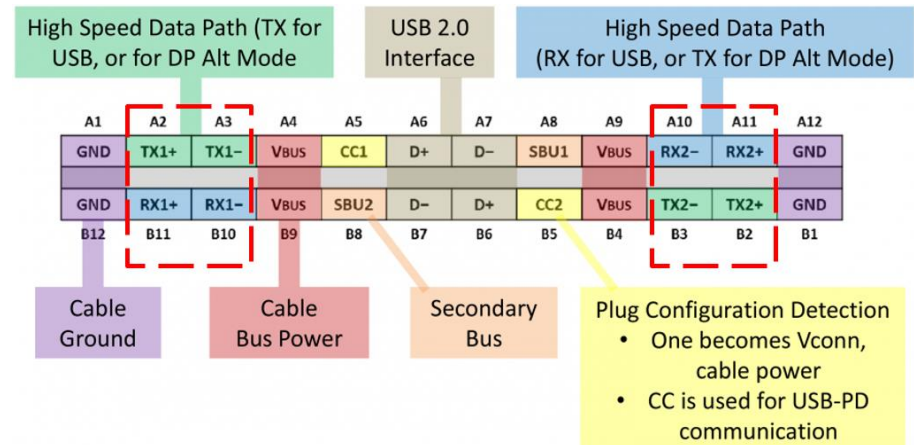
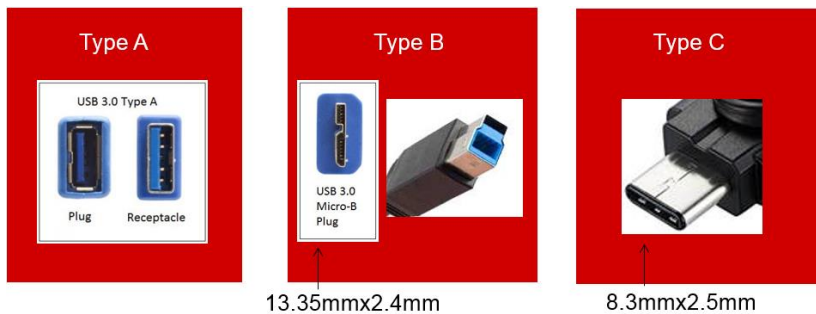



Alt Mode

A port could wake up as USB 3.1, then get configured to DisplayPort 1.3



THUNDERBOLT™

DisplayPort 1.3

Power Delivery 2.0

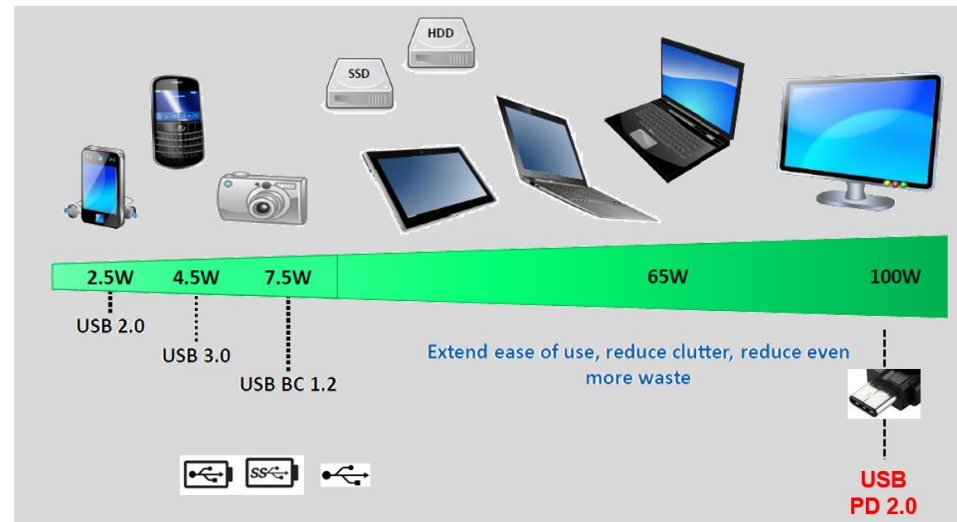

- Management of a power network and device modes through a one line interface. The interface can set up the network to quickly charge devices with up to 5 amps, supply power to active cables, discover cable functionality, enable guest protocols (Alternate Modes), facilitate device role and power direction *swaps*.

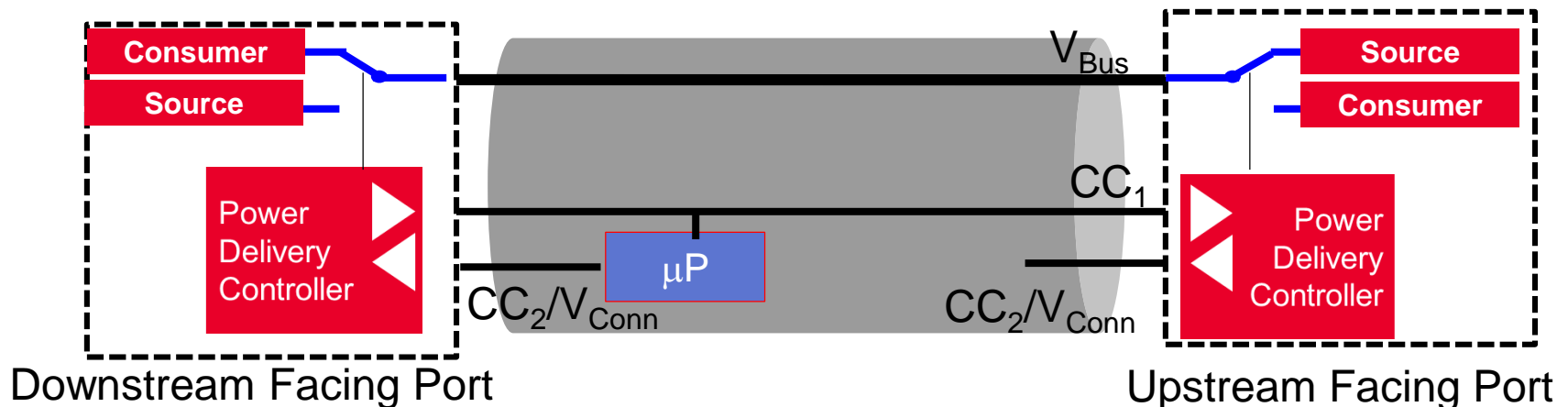

Keysight USB 2.0 Solution

N5416A/B USB 2.0 Compliance Test Application

USB Test -- USB device test results

Task Flow: Set Up | Select Tests | Configure | Connect | Run Tests | Results | HTML Report

| Test Name | Worst Actual | Worst Margin | Spec Range |
|--|--------------|--------------|---------------------------|
| ✗ EL_2 EL_4 EL_5 Data Eye and Mask Test | Fail | 100.0% | Overall Data Eye Test... |
| ✓ EL_6 Device Rise Time | Pass | 100.0% | Overall Rise Time Test... |
| ✓ EL_6 Device Fall Time | Pass | 100.0% | Overall Fall Time Test... |
| ✓ EL_7 Device Non-Monotonic Edge Test | Pass | 100.0% | Non-monotonic Edge ... |
| ✓ EL_21 Device Sync Field Length Test | 64.635ns | 46.3% | 63.600ns <= VALUE ... |
| ✓ EL_25 Device EOP Length Test | 16.97ns | 34.7% | 15.600ns <= VALUE ... |
| ✓ EL_22 Measure Interpacket Gap Between Second ... | 264.74ns | 35.2% | 16.640ns <= VALUE ... |
| ✓ EL_22 Measure Interpacket Gap Between First and ... | 269.51ns | 33.9% | 16.640ns <= VALUE ... |
| ✓ EL_18 Receiver sensitivity Test - Minimum SYNC Field | Pass | 100.0% | Minimum SYNC = Pass |

Eye Diagram

Details: Data Eye

Parameter: Trial 1

Test Limits

Parameter Test

Actual Value

Differentiated Mask

Signal Eye

Signal Eye Failure

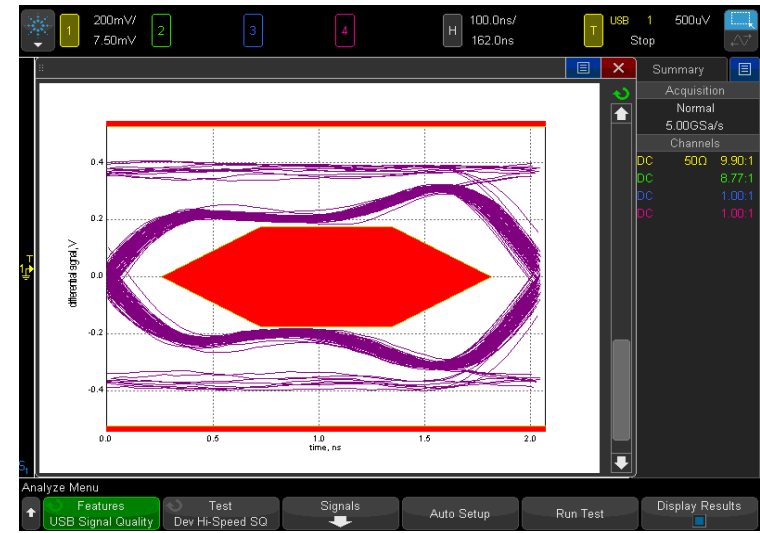

DSOX4USBSQ or DSOX6USBSQ

Waveform Area 1

200 mV / -100 mV

100 ns / 429.6341 ns

Protocol 1 Listing : USB 2.0

| Index | Time | USB 2.0 Packet | Address | Endpoint | Payload | Frame | CRC |
|-------|----------------|----------------|---------|----------|-------------------------|-------------|-----------|
| 1 | -13.6110792 µs | SOF | | | | 669 | 17 (GOOD) |
| 2 | -11.0072 ns | SETUP | 00 | 0 | | | 02 (GOOD) |
| 3 | 213.67072 ns | DATA0 | | | 00 05 00 01 00 00 40 00 | 94DD (GOOD) | |
| 4 | 855.0850 ns | ACK | | | | | |
| 5 | 3.0723340 µs | IN | 00 | 0 | | | 02 (GOOD) |
| 6 | 3.5549112 µs | NAK | | | | | |
| 7 | 5.7056863 µs | IN | 00 | 0 | | | 02 (GOOD) |
| 8 | 6.1882358 µs | NAK | | | | | |
| 9 | 8.3389163 µs | IN | 00 | 0 | | | 02 (GOOD) |
| 10 | 8.8217151 µs | NAK | | | | | |
| 11 | 14.2557004 µs | IN | 00 | 0 | | | 02 (GOOD) |
| 12 | 14.7546583 µs | NAK | | | | | |
| 13 | 16.9222582 µs | IN | 00 | 0 | | | 02 (GOOD) |
| 14 | 17.4212062 µs | NAK | | | | | |
| 15 | 19.5888931 µs | IN | 00 | 0 | | | 02 (GOOD) |
| 16 | 20.0878428 µs | NAK | | | | | |
| 17 | 22.2556732 µs | IN | 00 | 0 | | | 02 (GOOD) |
| 18 | 22.7545488 µs | NAK | | | | | |
| 19 | 24.9055968 µs | IN | 00 | 0 | | | 02 (GOOD) |

Keysight USB 3.1 Type-C Total Test Solution

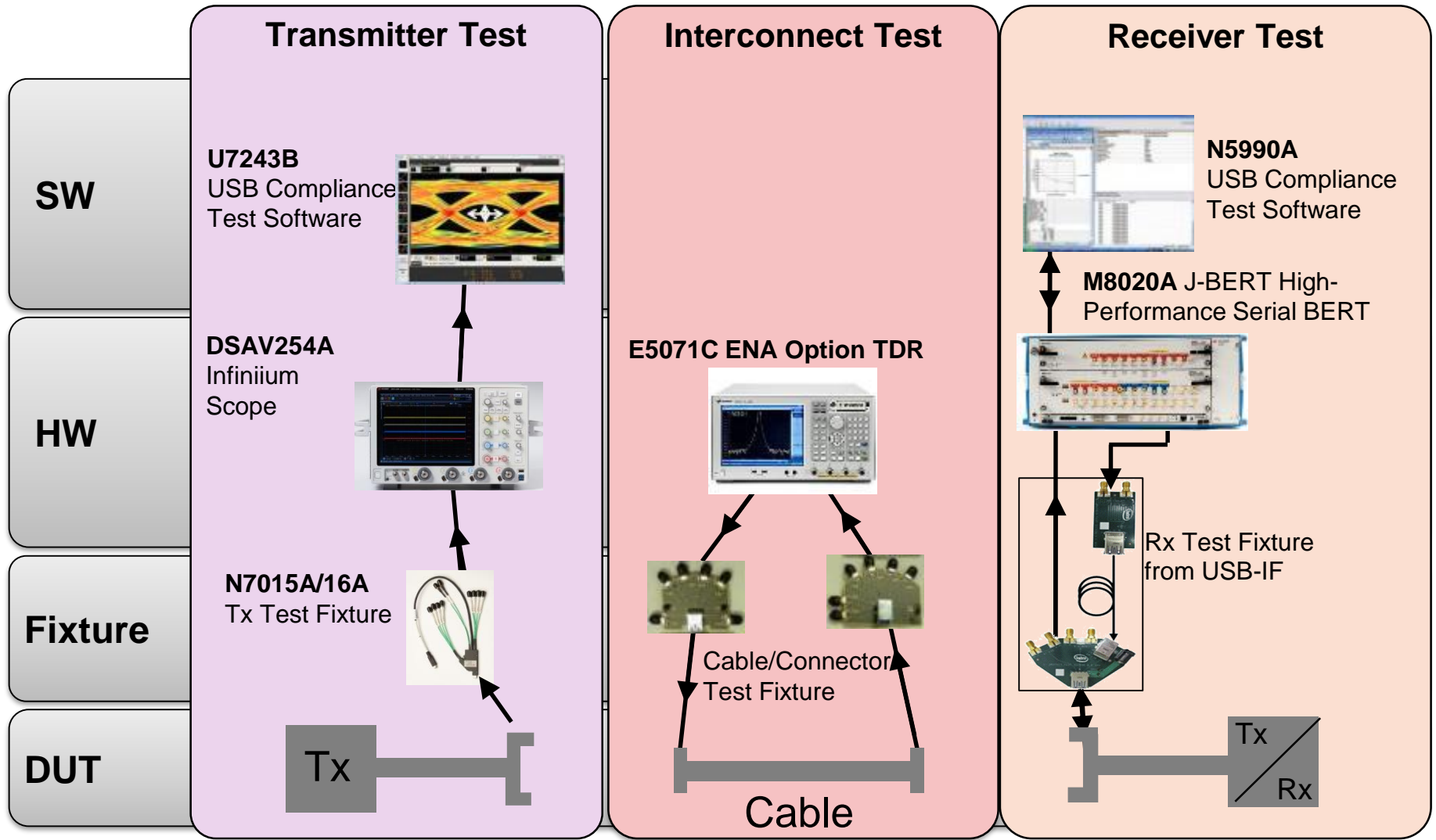
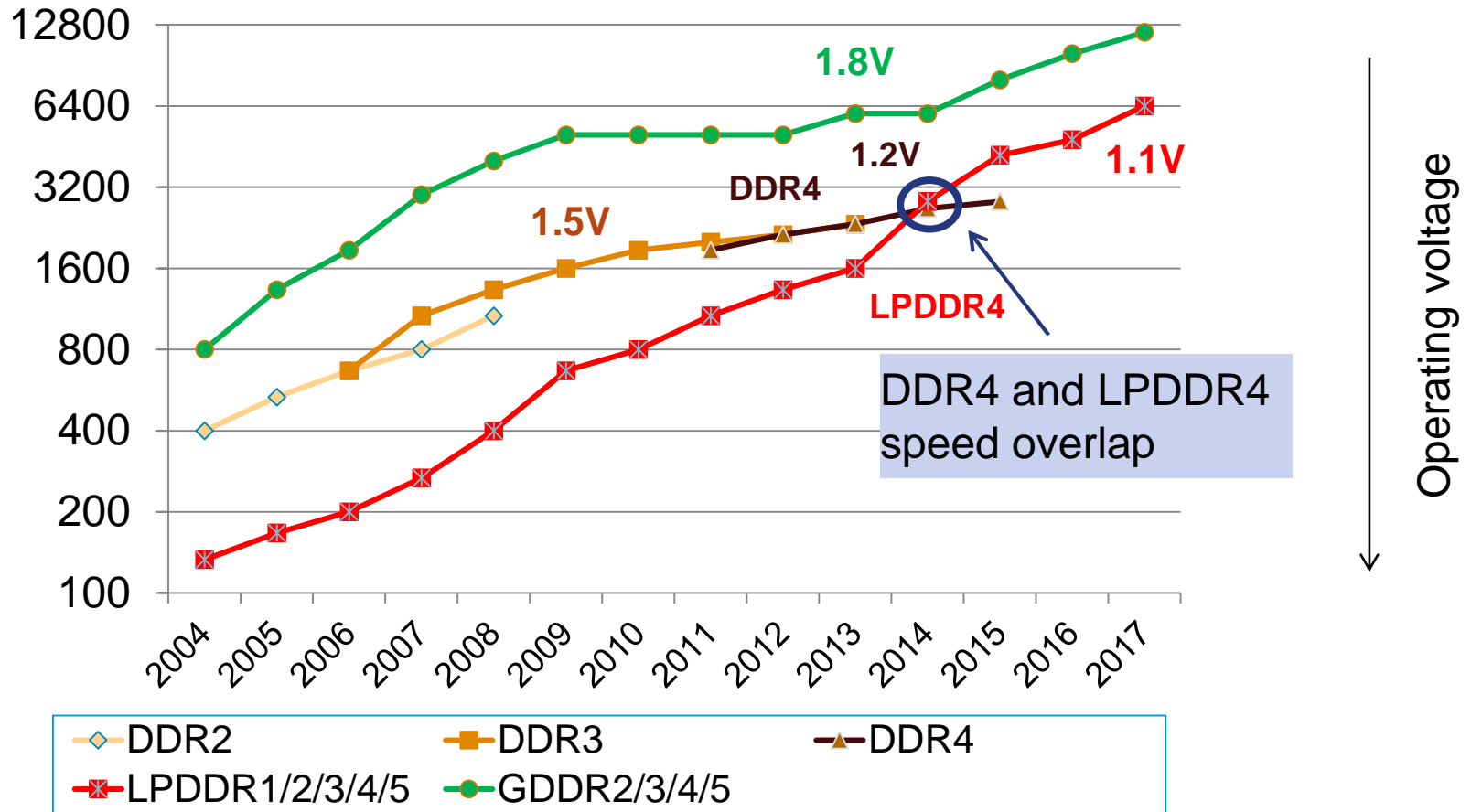

Table of Content

- Automotive Market Trend
- Different types of communication
- Keysight Solutions for Automotive Communication Test
 - CAN, LIN, SENT, CXPI, FlexRay, LVDS, BroadR-Reach
 - CAN, CANFD, CANdbc labs, SENT/CXPI examples
- Probing requirements
- **High Speed Digital Application for Automotive**
 - USB solution
 - **DDR solution**

DDR Memory Trends

Overlapping speed in DDR4 and LPDDR4



DDR4 x4/x8 BGA Interposer

Supports x4/x8 pin-out

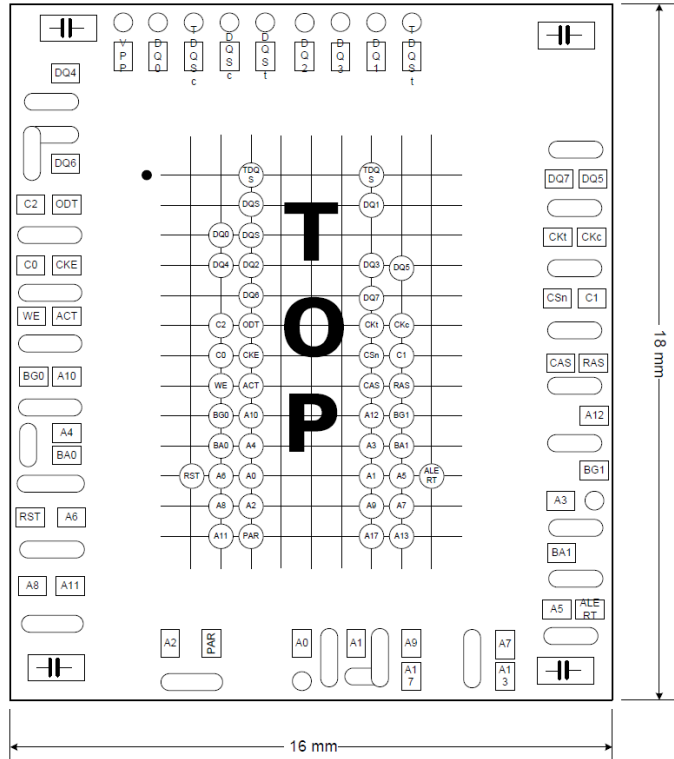

Note: All signals available at probe points except power, Vref, RFU

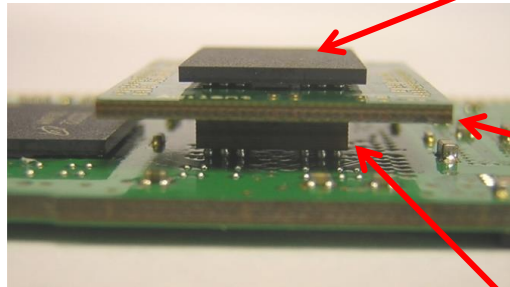

DDR4 BGA interposer soldered between PCB and DRAM. Zif probe heads provide connection to oscilloscope

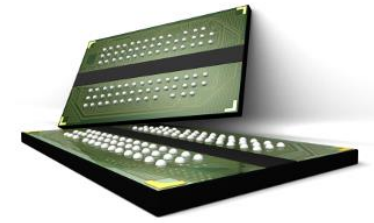

DDR4 DRAM

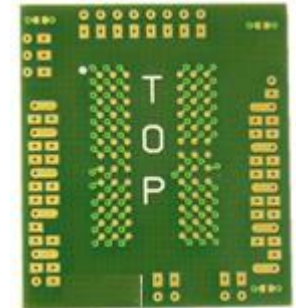

N2114A

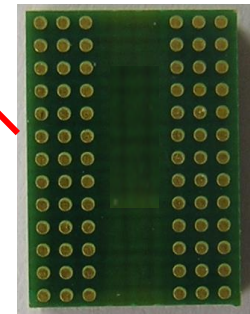

Riser

Elevates interposer for smaller surface keep-out area

Probing Correction with InfiniiSim

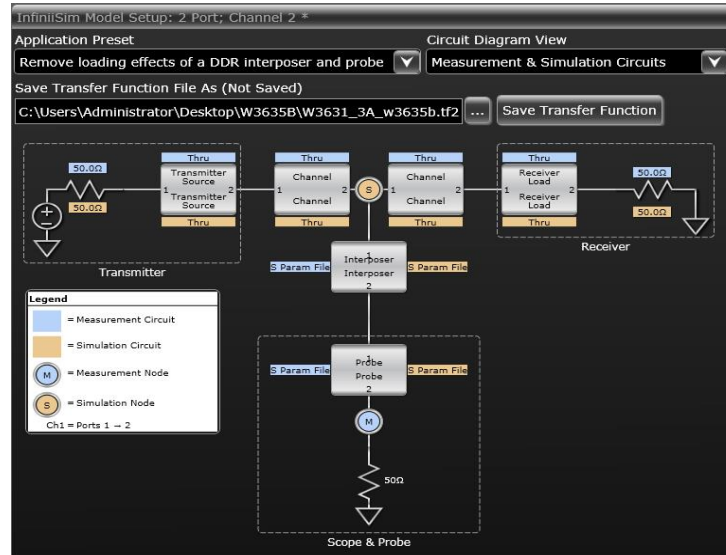
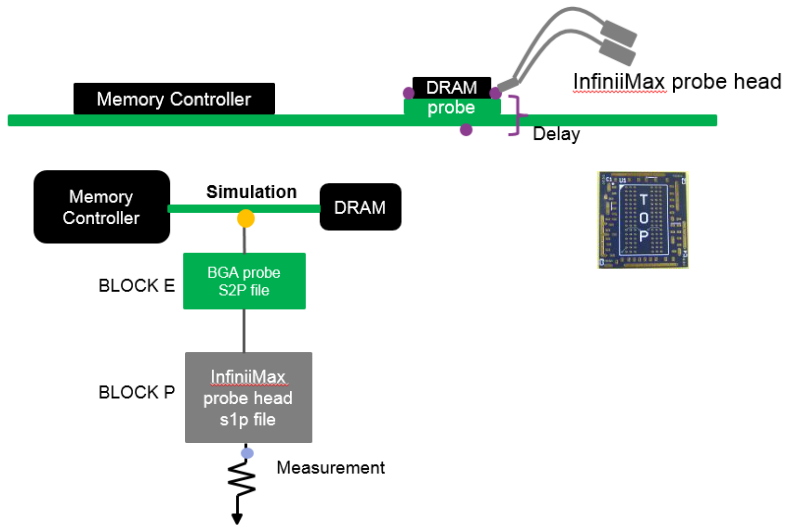

DDR4 2400

InfiniiSim on

- DQS (ch2)
- DQ (ch3)

InfiniiSim off

- DQS (m2)
- DQ (m3)

Read and Write Data Separation

Methods available today

1. InfiniiScan+ Zone trigger

- Requires identification of read and write data based on phase difference or pre-amble pattern.

2. Automated compliance test software

- For DDR4 – requires identification of read and write data with phase difference.
- For LPDDR4 – requires identification of pre-amble pattern.
- Both DDR4/LPDDR4 – Logic triggering of command bus with MSO

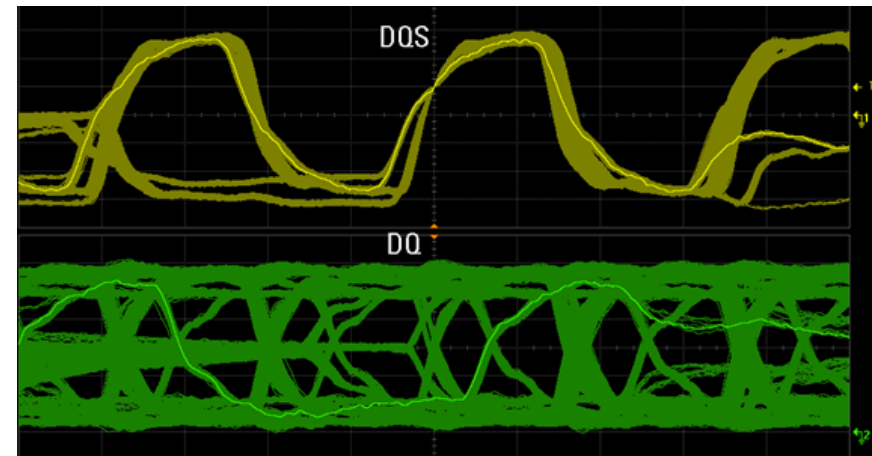

DDR Automated Compliance Test

Save cost and time

Based on JEDEC Specification

- Electrical
- Timing

Program (mask defined per spec)

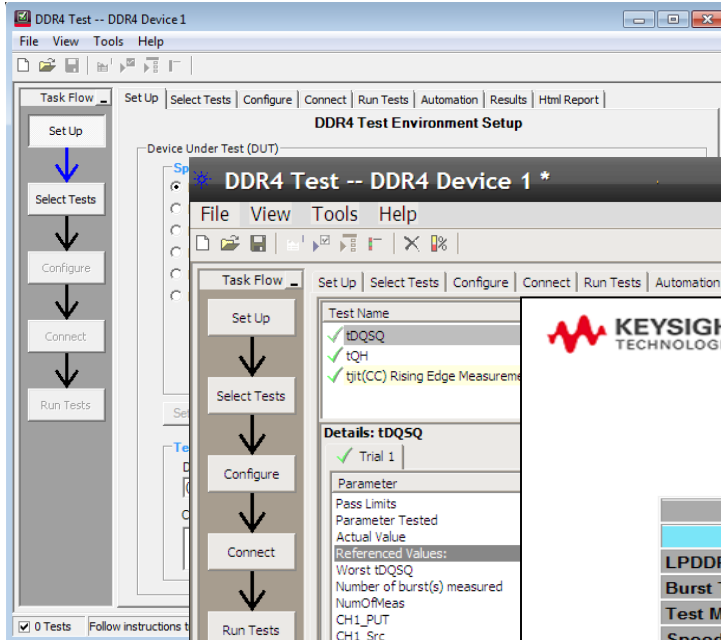

KEYSIGHT TECHNOLOGIES

DDR4 Test Report

Overview

Test Summary: **IMP** Test Description: Who preambles

Pass Limits: Info Only | **EWPRE**: 1.054849000000 ICK

Result Details

| Test | WVPR(s) | Number of burst(s) measured | NumOfMeas | CH1_PUT | Clock | CH1_Src | CH0_ACK | CH2_PUT | Strobe | CH2_Src | DQ50_DQ50 |
|-----------------------|---------|-----------------------------|-----------|---------|-------|---------|---------|---------|--------|---------|-----------|
| LPDDR4 | | 1.000000e+000 | 1.000 | | | | | | | | |
| Burst Triggering Meas | | | | | | | | | | | |
| Test Mode | | | | | | | | | | | |
| Speed Grade | | | | | | | | | | | |
| Infiniium SW Version | | | | | | | | | | | |
| Infiniium Model Num | | | | | | | | | | | |
| Infiniium Serial Num | | | | | | | | | | | |
| Application SW Vers | | | | | | | | | | | |
| Debug Mode Used | | | | | | | | | | | |
| Compliance Limits (| | | | | | | | | | | |
| Last Test Date | | | | | | | | | | | |

Summary of Results

| Test Statistics | |
|-----------------|---|
| Failed | 0 |
| Passed | 4 |
| Total | 4 |

| Margin Thresholds | |
|-------------------|-------|
| Warning | < 2 % |
| Critical | < 0 % |

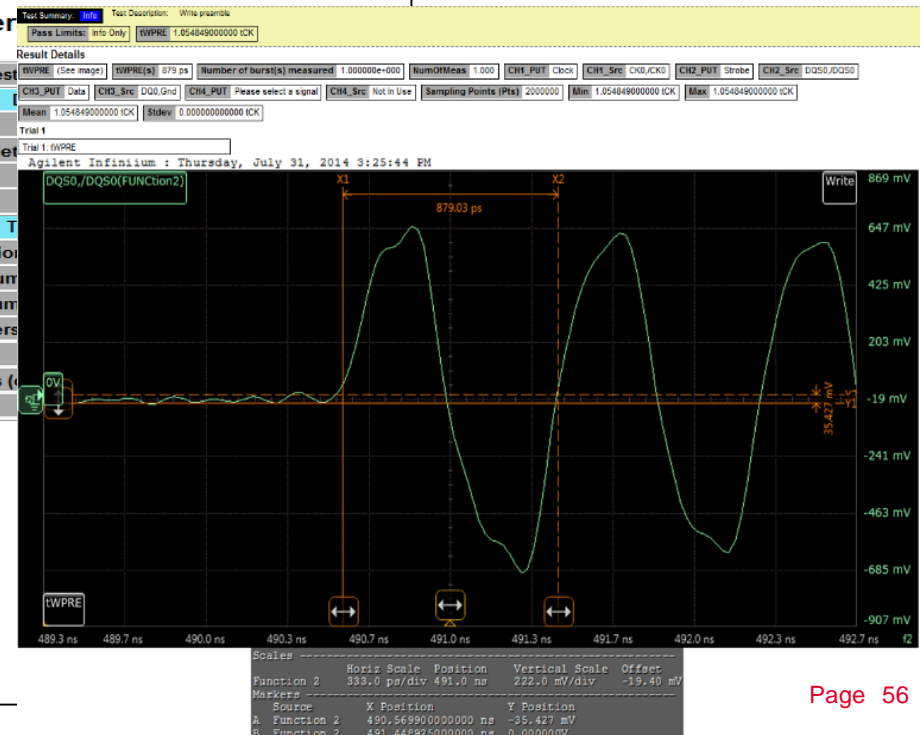

DDR Debug Tool

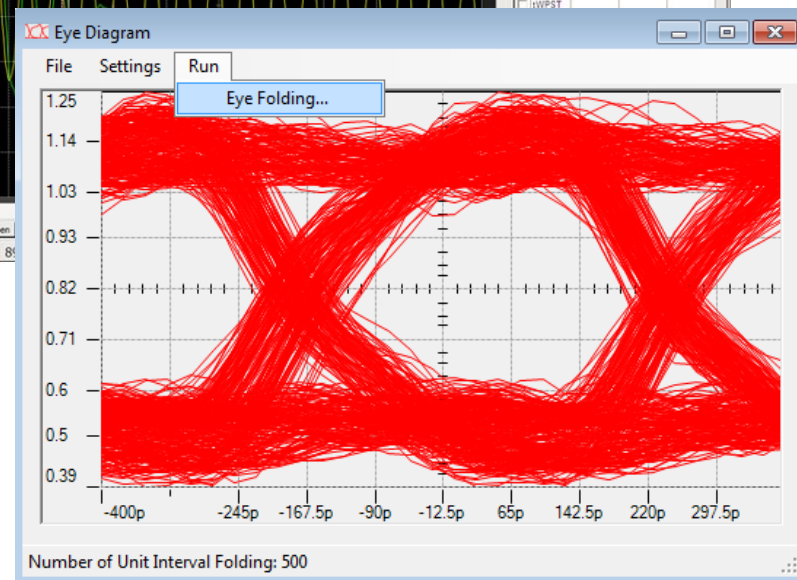
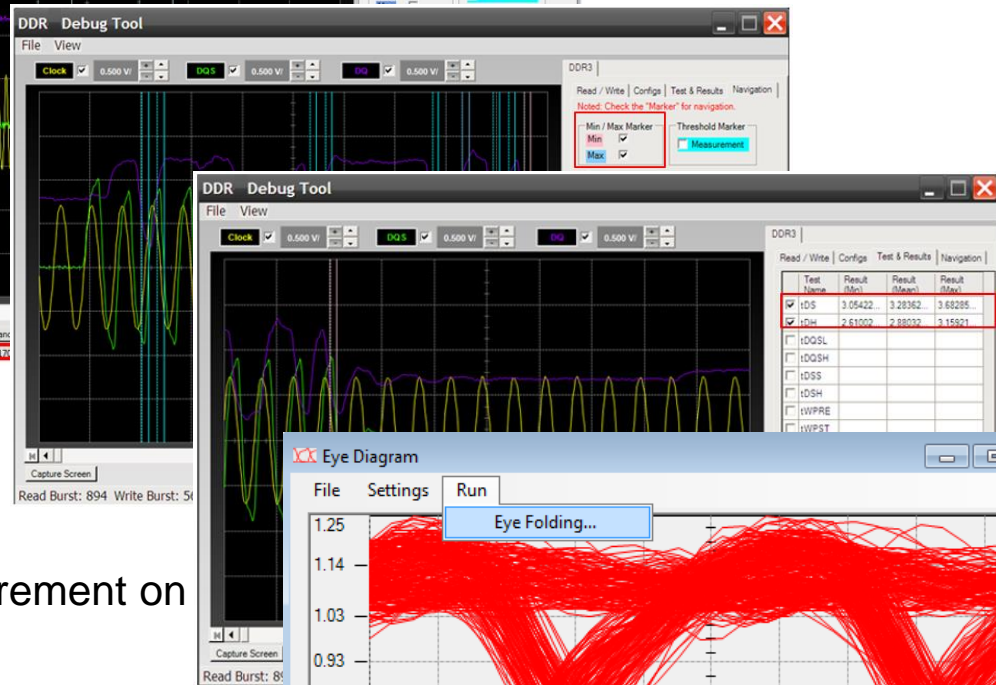
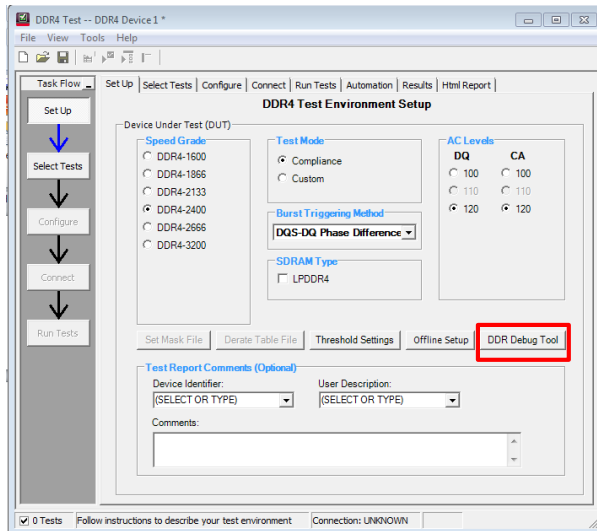

What is it?

- Identify read and write bursts.
- Make pre and post compliance measurement on saved traces.
- Collect statistical result with multi burst measurement.
- Navigate to measurement and read/write burst.
- Draw eye diagrams on saved read/write data. **NEW!**
- Display multiple eye diagrams. **NEW!**

Offline tool use model with ADS Simulation tool

Test flow from ADS to DDR Compliance Testing

W2351EP DDR4 Compliance Test Bench

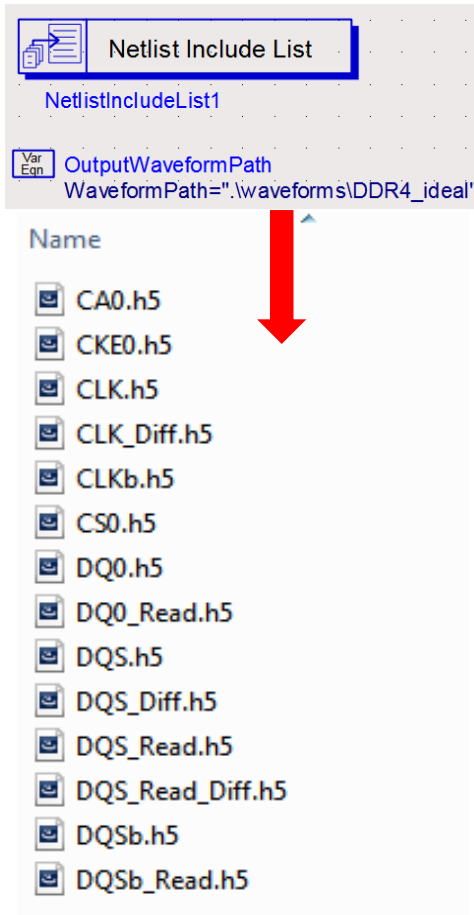

Netlist Include List

NetlistIncludeList1

Var Ean OutputWaveformPath
WaveformPath=".\\waveforms\\DDR4_ideal"

Name

- CA0.h5
- CKE0.h5
- CLK.h5
- CLK_Diff.h5
- CLKb.h5
- CS0.h5
- DQ0.h5
- DQ0_Read.h5
- DQS.h5
- DQS_Diff.h5
- DQS_Read.h5
- DQS_Read_Diff.h5
- DQSb.h5
- DQSb_Read.h5

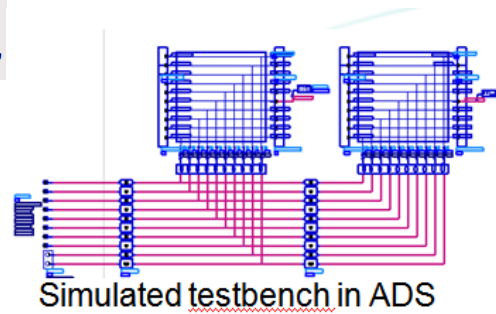

ADS "Waveform Bridge": Script that writes file format that 'scope compliance app understands



Compliance app performed **offline** on PC



Live signal from DUT

Live signal acquired by scope



Compliance app performed **live** on scope

Cygnit Data Analytics N8844A

N6462A LP/DDR4 compliance test software

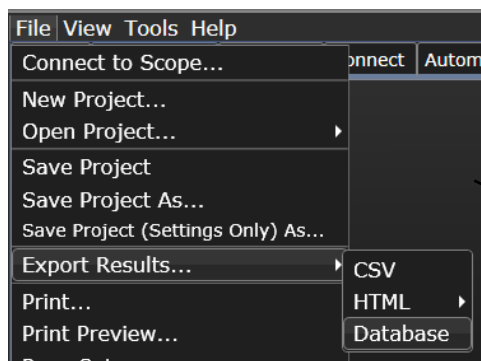

| name | Virtual Memory | Working Set | Private Memory | Non-paged memory |
|---------------|----------------|-------------|----------------|------------------|
| 1 atiechxx | 66068480 | 6533120 | 2588672 | 9736 |
| 2 atiesrxx | 33804288 | 4505600 | 1765376 | 7632 |
| 3 audioiog | 50356224 | 15941632 | 15011840 | 9424 |
| 4 CCC | 674254848 | 6746112 | 61571072 | 79332 |
| 5 conhost | 85331968 | 7323648 | 2846720 | 7920 |
| 6 crsss | 57634816 | 5296128 | 3284992 | 13568 |
| 7 crsss | 110956544 | 14876672 | 8941568 | 19896 |
| 8 DCPsysMq | 109682688 | 12632064 | 8765440 | 13208 |
| 9 DCPsysMq | 59002880 | 7610368 | 2768096 | 11408 |
| 10 Dell.Conti | 605573120 | 49803264 | 43466752 | 42724 |
| 11 dpupdchk | 116756480 | 1089456 | 4263936 | 15816 |
| 12 dwm | 201625600 | 50298880 | 38662144 | 23224 |
| 13 explorer | 451448832 | 113147904 | 88936448 | 80720 |

Microsoft Excel spreadsheet

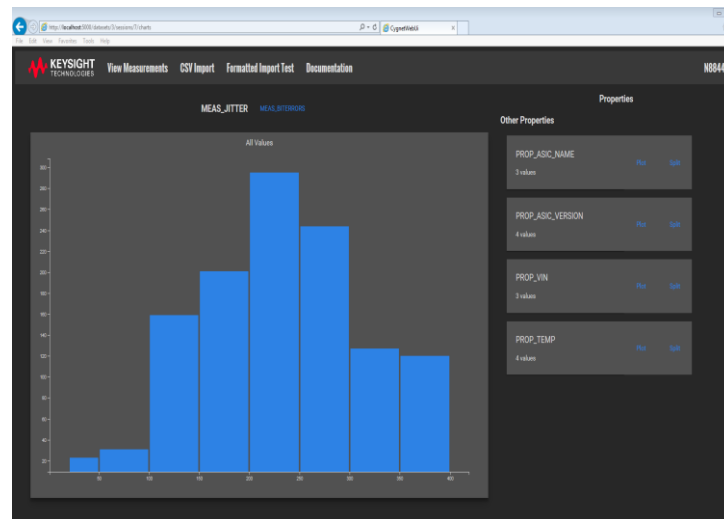

N8844A Web ResultViewer

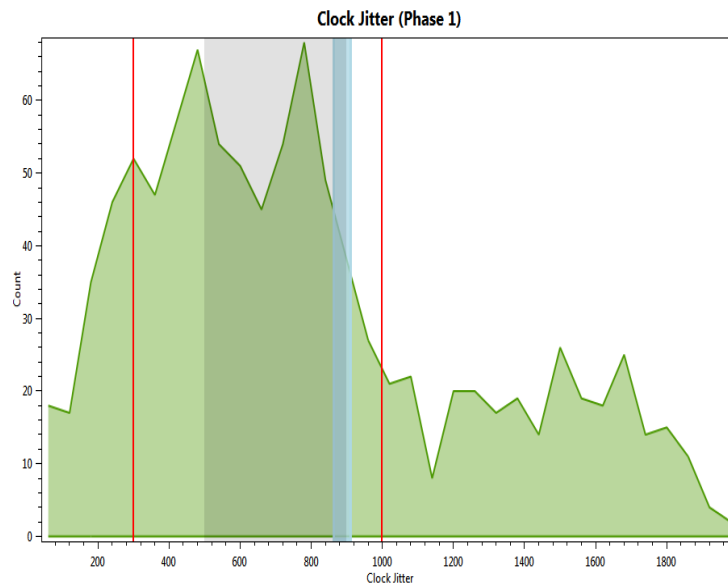

KS8400A Results Viewer software

DDR / LPDDR Protocol Trigger & Decode

Perform DQ characterization with Protocol view

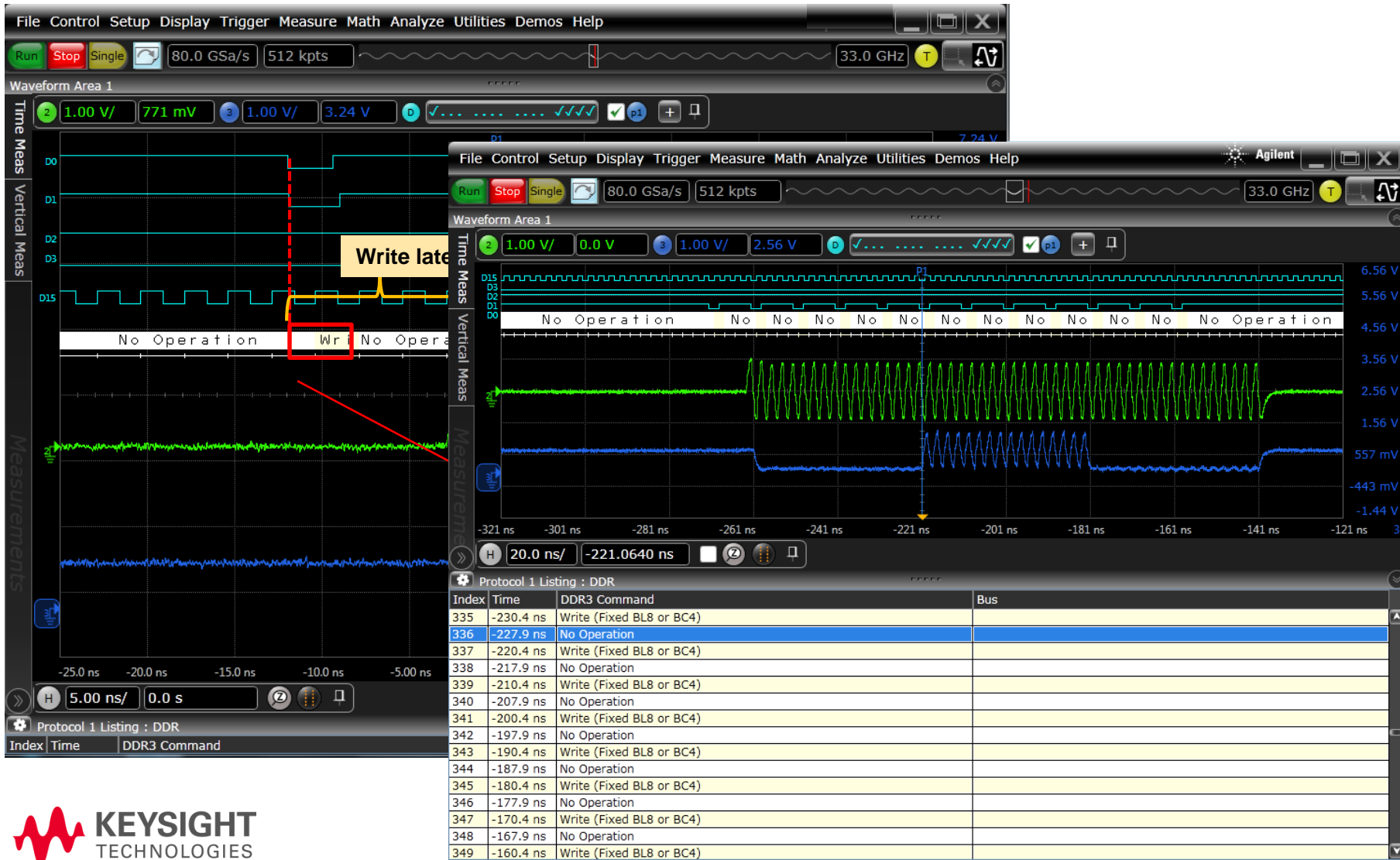

Comprehensive DDR Protocol Insight with Logic Analyze

Connect

Acquire

View & Analyze



DIMM / SODIMM Interposers



BGA interposers



Mid-Bus & specialty Probing

**Proven
4 Gb/s!**



**Capture highest data rates!
4 Gb/s**

**Capture smallest eyes!
100mV x 100ps at probe point.**

**Sequential Triggers up to
2.5GHz or 4Gb/s!**

**12.5GHz Timing Zoom
256k deep**

Up to 400M deep traces

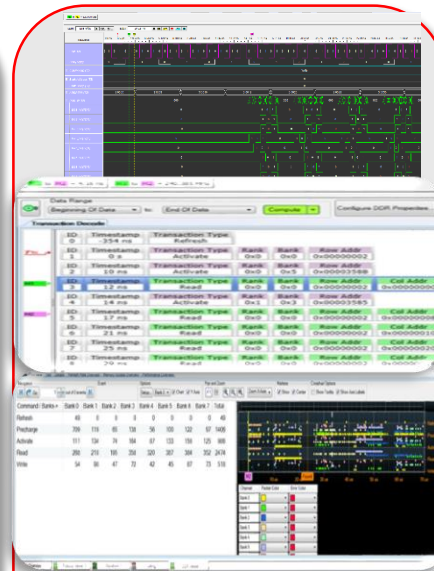

Waveforms

**Listing with Decoders
Traffic Overview**

**Protocol Compliance
across Speed changes
Performance Analysis**

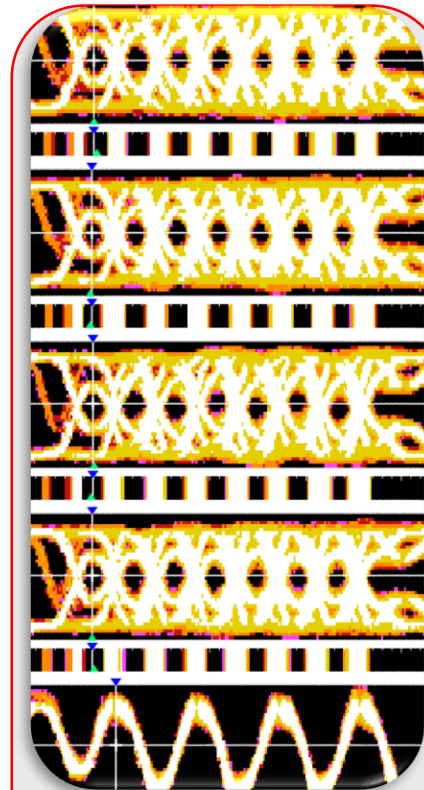

**Bus Level Signal
Integrity Insight**

**New
B4661A
Memory
Analysis
SW**

Thank you