

# Ethernet 기술의 진화 및 Ethernet 물리 계층 적합성 평가 방법에 대한 고찰

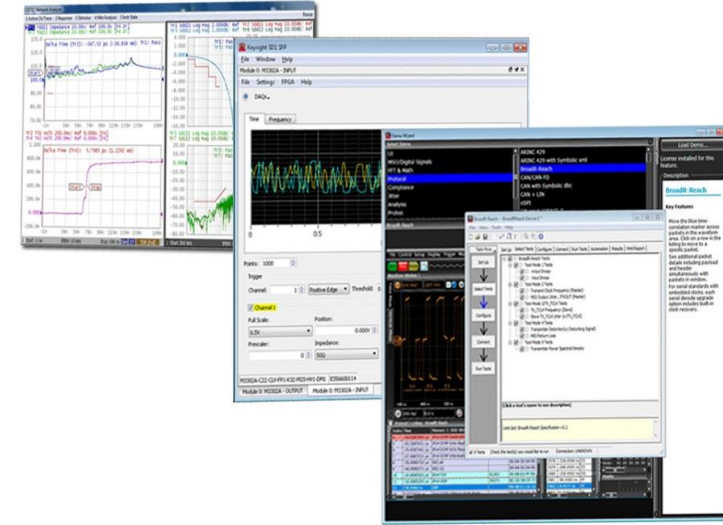

Apr. 3 2018

Dong-Hyun, Seo

# Agenda - what you can expect

*What Is Ethernet?*

*Product Overview*



# Alphabet Soup with Diagram...

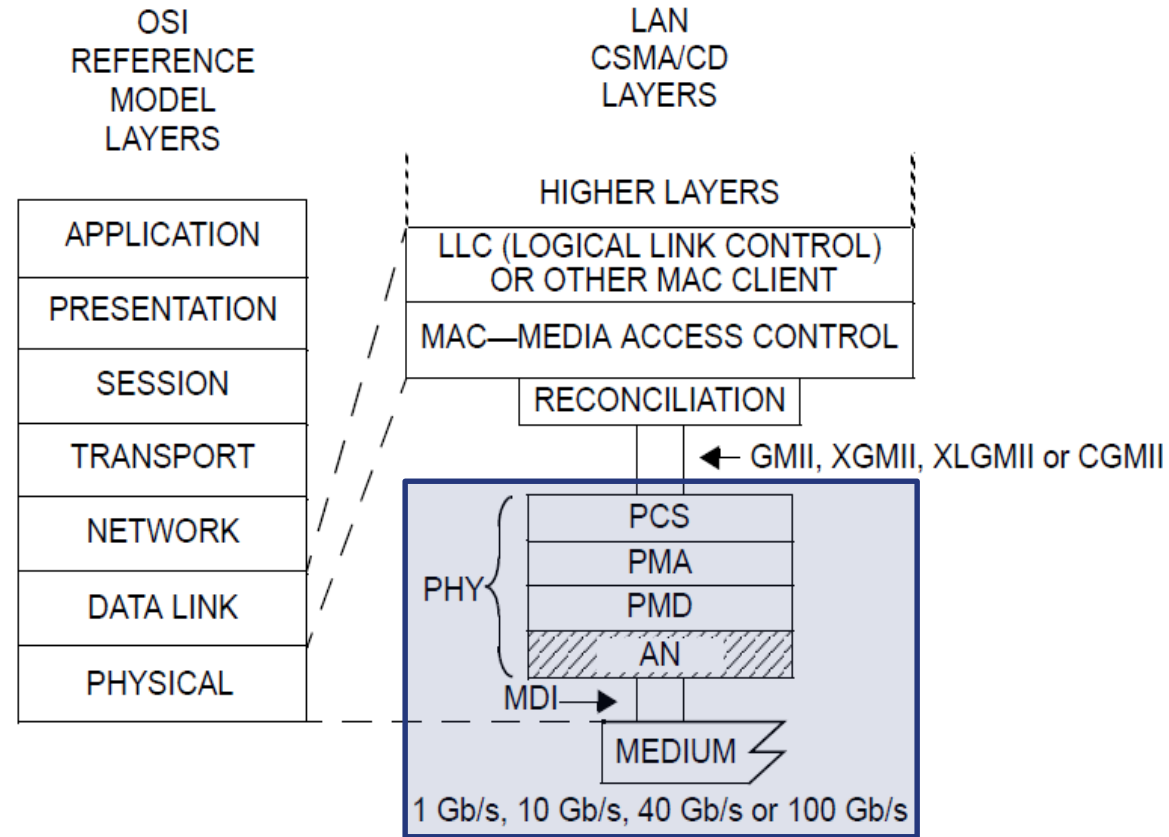

AN = AUTO-NEGOTIATION

CGMII = 100 Gb/s MEDIA INDEPENDENT INTERFACE

GMII = GIGABIT MEDIA INDEPENDENT INTERFACE

MDI = MEDIUM DEPENDENT INTERFACE

PCS = PHYSICAL CODING SUBLAYER

PHY = PHYSICAL LAYER DEVICE

PMA = PHYSICAL MEDIUM ATTACHMENT

PMD = PHYSICAL MEDIUM DEPENDENT

XGMII = 10 Gb/s MEDIA INDEPENDENT INTERFACE

XLGMII = 40 Gb/s MEDIA INDEPENDENT INTERFACE

# OSI Model and PHY layer what we test for compliance

- **XGMII** – 10Gb/s Medium Independent Interface
- **XAUI** – 10G Ethernet Attachment Unit Interface
- **PCS** – Physical Coding Sublayer – this is where 4B/5B, 8B/10B, 64B/66B encoding takes place
- **PMA** – Physical Medium Attachment – Optional interface for optical interfaces such as XAUI and XSBI
- **PMD** – Physical Medium Dependent – Single and Multimode Optical fiber interfaces for long distances.
- **MDI** - Media Dependent Interface (MDI), this is typically a RJ-45 connector.

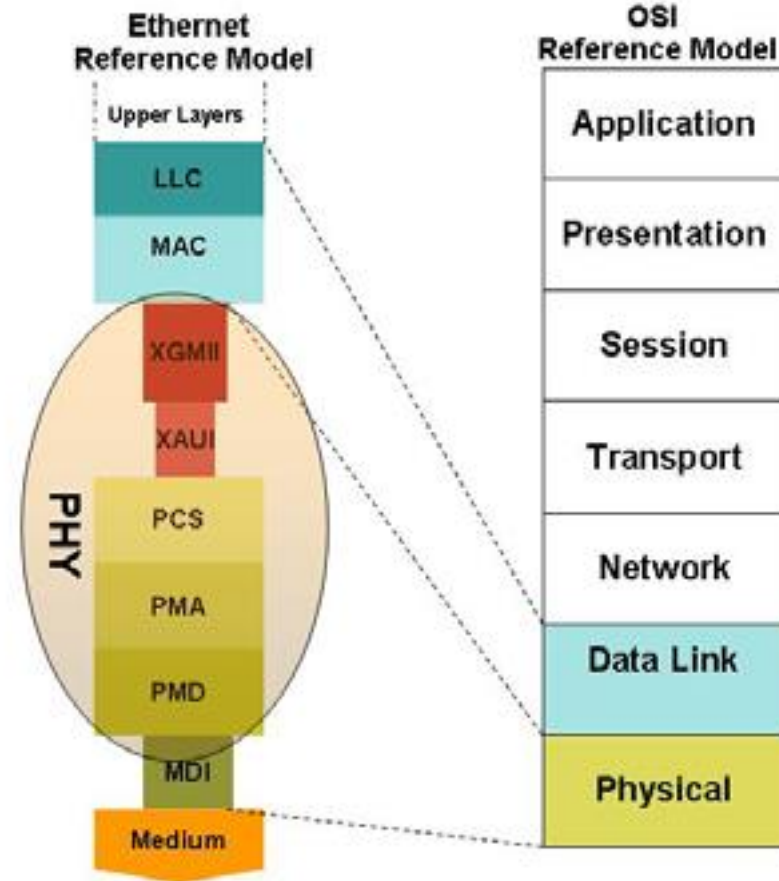

# Nomenclature...

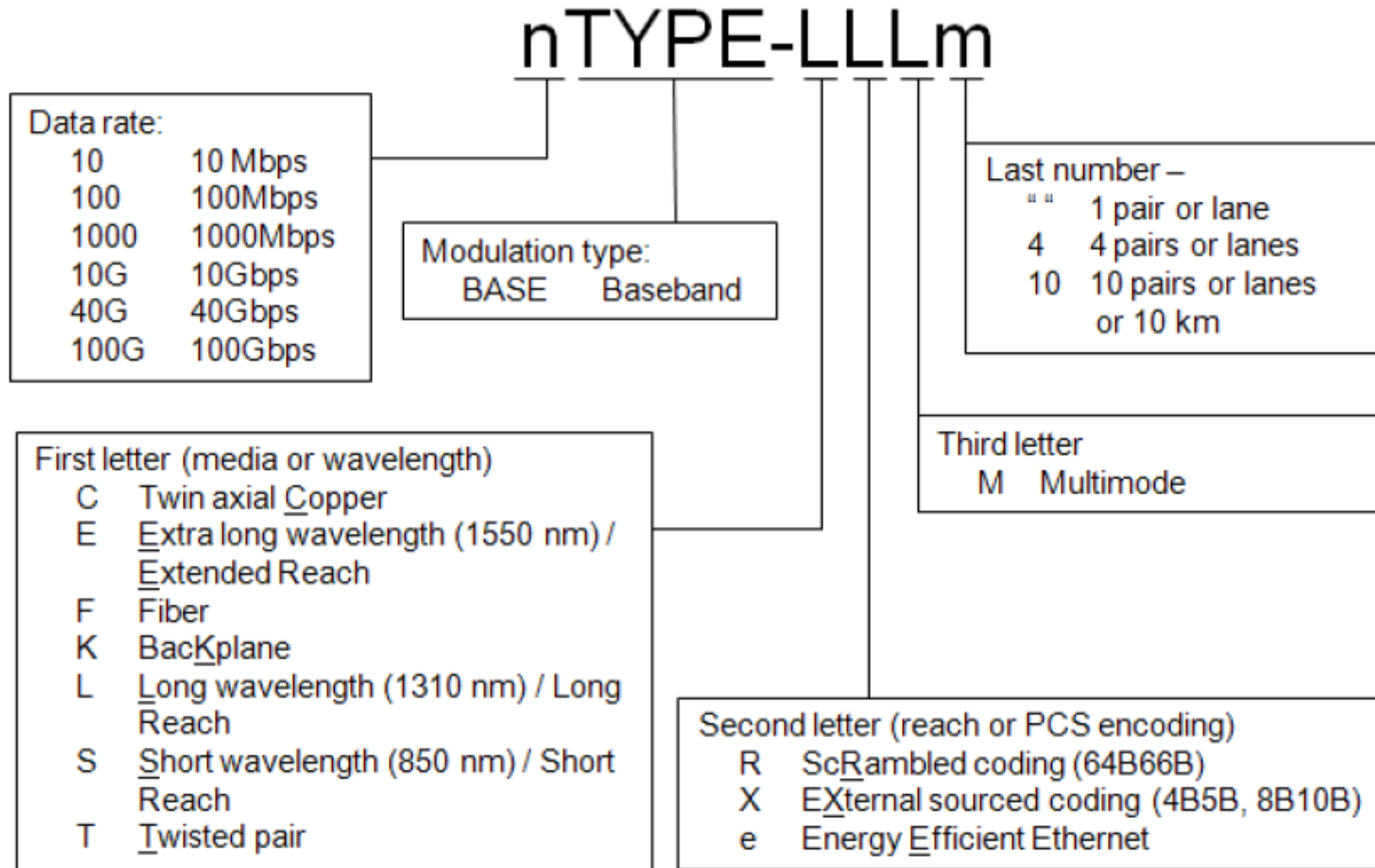

# Technology Summary

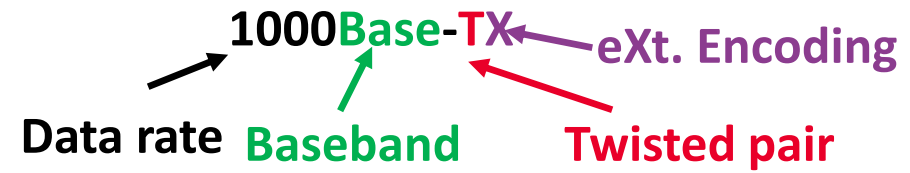

Standard	Common Name	Data Rate	Cabling	Max Length
10Base-T (802.3i)	Ethernet	10 Mb/s	2 twisted pairs, 100 ohms, Category 3 or higher, RJ-45 connectors	100 m
100Base-TX (802.3u/ANSIX3.263-1995)	Fast Ethernet	100 Mb/s	2 twisted pairs, 100 ohms, Category 3 or 5 ("Cat-5"), RJ-45 connectors	100 m
1000Base-T (802.3ab)	Gigabit Ethernet	1000 Mb/s	4 twisted pairs, 100 ohms, Category 5, RJ-45 connectors	100 m
10GBase-T (802.3an)	10 Gigabit Ethernet	10 Gb/s	4 twisted pairs, 100 ohms, Category 6A, RJ-45 connectors	100 m
10GBase-KR K-backplane R-sRambled (802.3ap)	10 Gigabit KR	10 Gb/s	2 pairs(TX/RX), 100 ohms, FR4 Copper Backplane	1 m
10/100/1000 Base-Te (802.3az)	Energy Efficient Ethernet (EEE)	10 Mb/s 100 Mb/s 1000 Mb/s	2 and 4 twisted pairs, 100 ohms, Category 5 or higher, RJ-45 connectors	100 m

# Ethernet Technology Summary

Ethernet is all the same...reeeeeeeeeeeeeeeeeeally 

Schemes	10BASE-T	100BASE-TX	1000BASE-T	10GBASE-T
Data rate	10 Mbps	100 Mbps	1Gbps	10Gbps
Modulation	Manchester Encoding	NRZI None Return to Zero Inverted	PAM-5	PAM-16
Pairs / Line Rate	2 10 Mbaud	2 125 Mbaud	4 125 Mbaud	4 833 Mbaud
Incremental noise cancellation support	Twisted Pair wire and Differential signaling	NEXT	NEXT, FEXT, (echo -cancellation)	NEXT, FEXT, echo, Alien Crosstalk (ANEXT, AFEXT)
Cabling	CAT3	CAT5	CAT5e	CAT6a or better
Line Coding	None	Multi-Level Transmission (MLT-3)	8-state 4D Trellis code across pairs	Tomlinson-Harashima Precoding (THP)
Signal Encoding	Binary	4B/5B	8B/10B	LDPC+DSQ128

# Data Rate vs. Line Rate...



– What is the difference between Data rate and Line Rate, I'm confused???

Standard	Data Rate or Bit Rate (Bit/s)	Line or Symbol Rate (Baud or Symbols/s)	Analog Bandwidth (Hz)	Encoding	Pairs
10Base-T	10M	10M	~10M	Manchester	2
100Base-TX	100M	125M	~62.5M	4B/5B, MLT-3	2
1000Base-T	1G	125M	~80M	8B/10B, PAM-5	4
10GBase-T	10G	833M	~400M	LDPC+DSQ128, PAM-16	4
10GBase-KR	10G	10.3125G	10.3125G	64B/66B	2

MLT – Multi Level Transmit

PAM – Pulse Amplitude Modulation

LDPC – Low Density Parity Check

DSQ128 - Double Squared 128

How efficient are the encoding schemes?

- 4B/5B= 25% overhead
- 8B/10B = 25% overhead
- 64B/66B = 3.125% overhead

# Pulse Amplitude Modulation 5 (PAM-5) Encoding

- Single lane of 1000Base-T baseband modulation path...

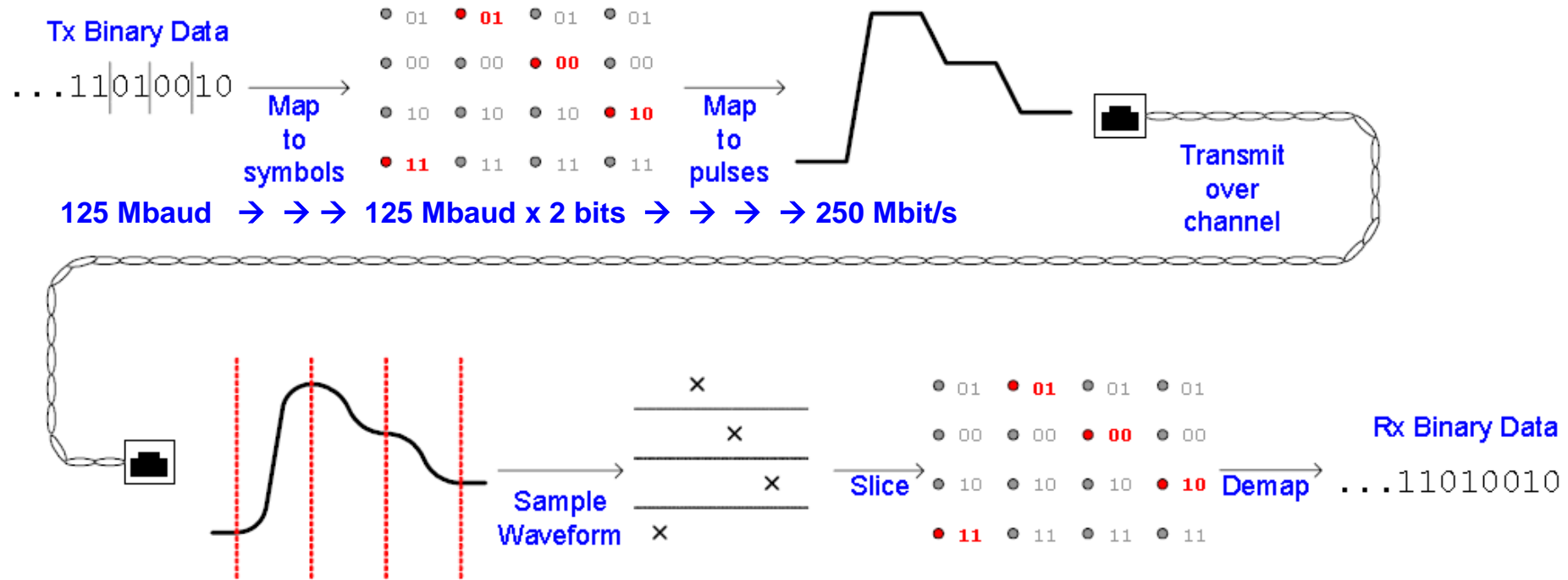

**1000Base-T = 125 Mbaud x 2 bits x 4 lanes = 1Gbit/s**

**10GBase-T = 833 Mbaud x 3 bits x 4 lanes = 10Gbit/s**



Where is the fifth level, I only see 4? The extra level in the PAM-5 scheme provides some code redundancy that is used to define control characters and to improve performance.

# Pulse Amplitude Modulation 5 (PAM-5) Encoding

- PAM-5 digital symbols vs. voltage threshold...

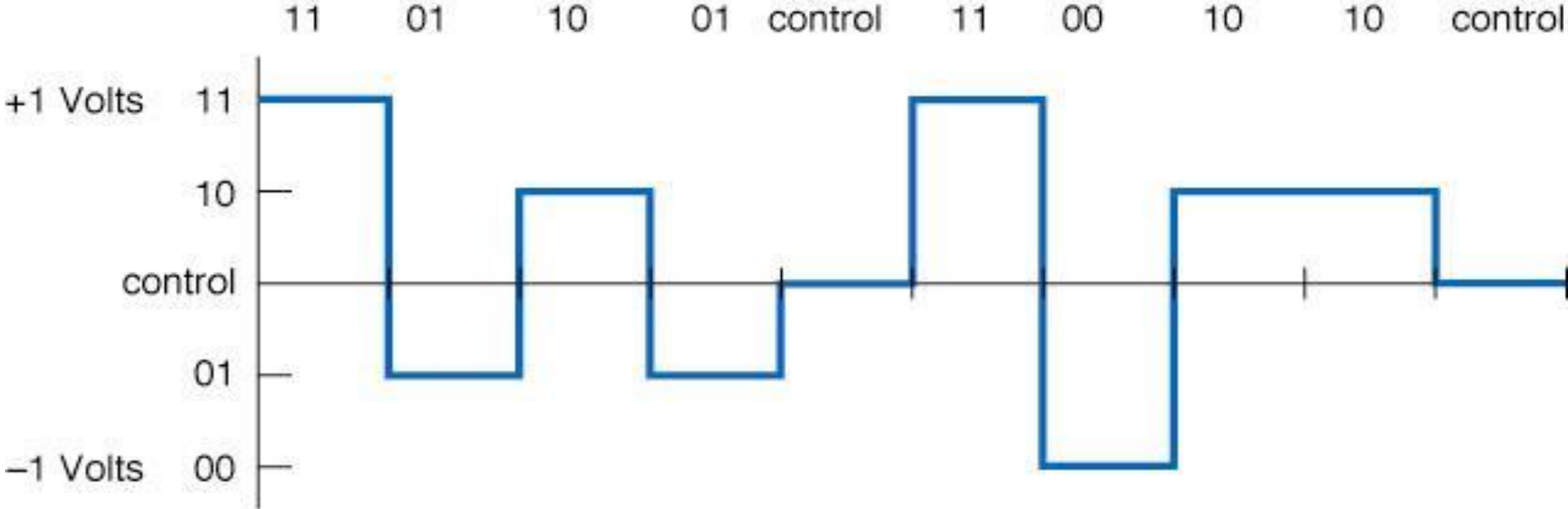

– Note that control is at the 0 volt mark

# Energy Efficient Ethernet: What is it?

Energy Efficient Ethernet or EEE (triple E) as it is known in the industry is simply a means to scale power consumption in network controllers when they are not transmitting data. Some Ethernet controllers have the ability to analyze the length of any Ethernet cable connected to them and adjust the power usage accordingly. Shorter lengths require less power which means they save even more energy.

## Why EEE?

As the world becomes increasingly connected, there is the tradeoff of increased demand for power. In order to help curb this need, EEE is seen as an incremental step to reduce power consumption. A Lawrence Berkeley Labs researcher estimates that adoption of EEE in the networking and networked device markets would result in energy savings of \$450 million or more per year in the US (Merritt, 2008).



# Energy Efficient Ethernet: How does it work?

## How does it Work?

The power savings from a purely percentage basis is significant, but how does EEE work? Let's start off with the example of traffic flowing between a remote (server) and local (client) PHYs with network and switching equipment between them.

Both devices will advertise and handshake the capability to support EEE (802.3az-2010) at power up. Once the handshake is completed, the remote PHY knows it can initiate a Low Power Idle (LPI) signature (figure 2) to the local PHY.

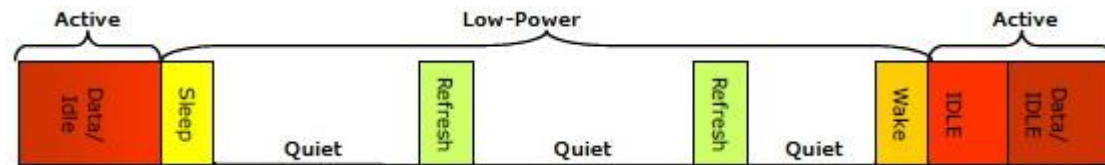
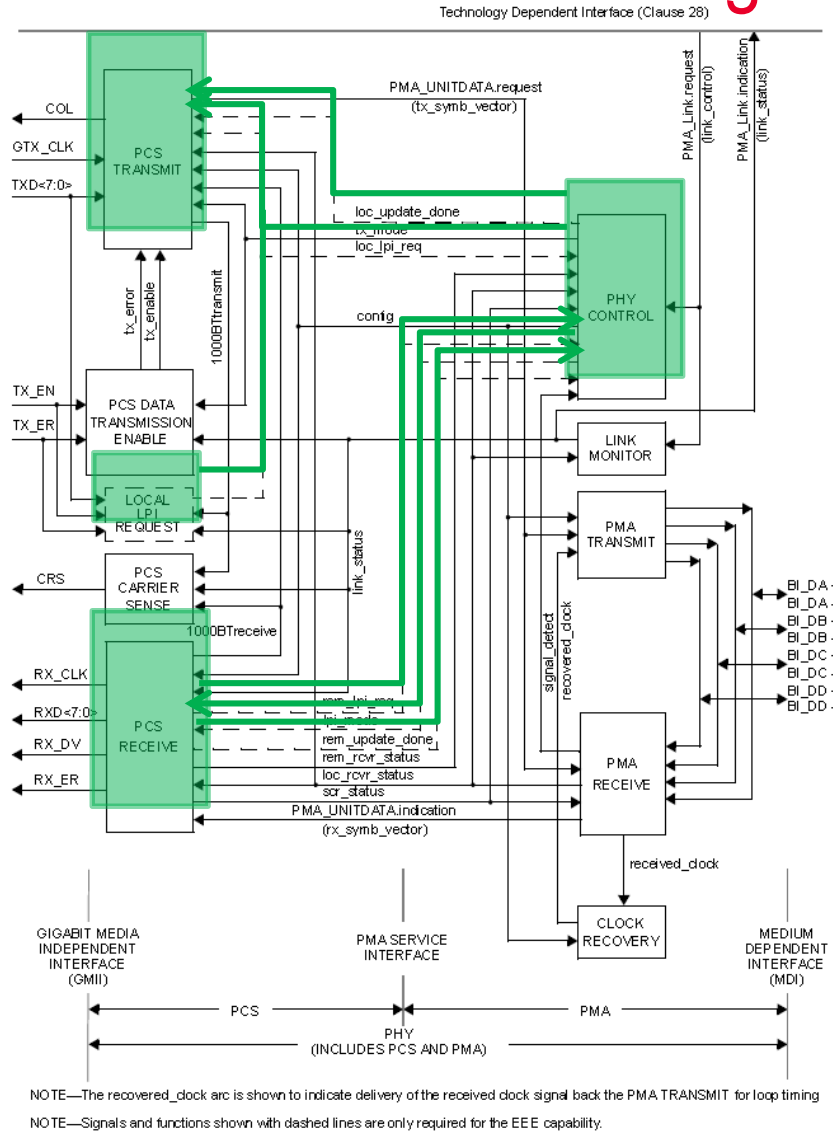

Figure 2: LPI Signature

From figure 2, the LPI sleep and wake signals are initiated by the remote PHY between periods of activity. Once the local PHY is asleep, periodic refreshes are sent to the client in order to update adaptive filters and timing circuits in order to maintain link integrity. It is during the low-power state where power savings are realized at the local PHY because it is allowed to switch off part of the receive and transmit circuitry.

Once there is data to be transmitted, the remote PHY sends a wake signal and data packets are then transmitted.

# EEE Device Interface Block Diagram



## 1000BASE-Te Interface block

- All green blocks and lines indicate EEE capability
- Transmitter as well as receiver circuits can be shut down
- As seen in the diagram the PHY controller has the responsibility of controlling and shutting down both Tx/Rx functions of the PCS (Physical Coding Sublayer).

# Energy Efficient Ethernet...Use Model



## How Efficient?

- ✓ Lowers Power by 70%-90%

## What Devices?

- ✓ Switches, Storage
- ✓ Servers, PC/Laptops
- ✓ VoIP Phone, Printers
- ✓ TV's, Game Consoles

## Supports Spec:

- ✓ 802.1az-2010 (EEE)

## Supported Speeds...

- ✓ 10/100/1000Base-T
- ✓ 10GBase-T
- ✓ 10GBase-KR

# Common Ethernet Compliance App Questions...

- What Ethernet technology are you using?
  - 10/100/1000Base-T or other Ethernet technology.
- Are you doing TX testing on your Ethernet controller?
  - Our compliance app does all of the TX testing for you.
- Are you connected using an RJ45 connector or cable?
  - We can do RJ45 but not fiber or SFP.
- Do you have control over your DUT so that you can produce compliance test patterns?
  - You must be able to have register control over the Ethernet DUT in order to generate the compliance test patterns. Typically these tools come from the Ethernet chip vendor.
- Does the DUT need a link partner to keep a steady link pulse?
  - Connect another PC/Laptop to the DUT through the fixture.
- Does the DUT mistakenly autonegotiate the link partner to 1GBT when testing 10BT or 100BT?
  - Use LAN card properties to force the card into 10BT or 100BT link mode.

# Agenda - what you can expect

*What Is Ethernet?*

*Product Overview*

Keysight offerings, Product Highlights



# E5392A/B 10BASE-T/100BASE-TX/1000BASE-T Ethernet Compliance Test Solution



# N5392A/B Ethernet TX Test Setup

Industry's **unique and only** test coverage for protocol as well as compliance

## DSOS254A

High-Definition Oscilloscope: 2.5 GHz, 4 Analog Channels, 800 Mpts memory



## E5071C

ENA Vector Network Analyzer: 5 Hz to 20 GHz

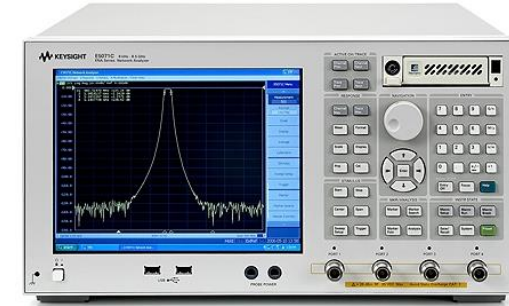

## 81150A

Pulse Function Arbitrary Noise Generator



1131A + E2678B



15443A



N5395C Ethernet Test Fixture





# Energy Efficient Ethernet Fixture

– MFG by Wilder Technologies

- [www.wilder-tech.com](http://www.wilder-tech.com)

Fixture Only: EEE-TPA-ER

Fixture + Kit P/N: EEE-TP



– Fixture Supports...

- 10BTe, 100BTe, 1000BTe
- Exclusive Licensed Keysight Part

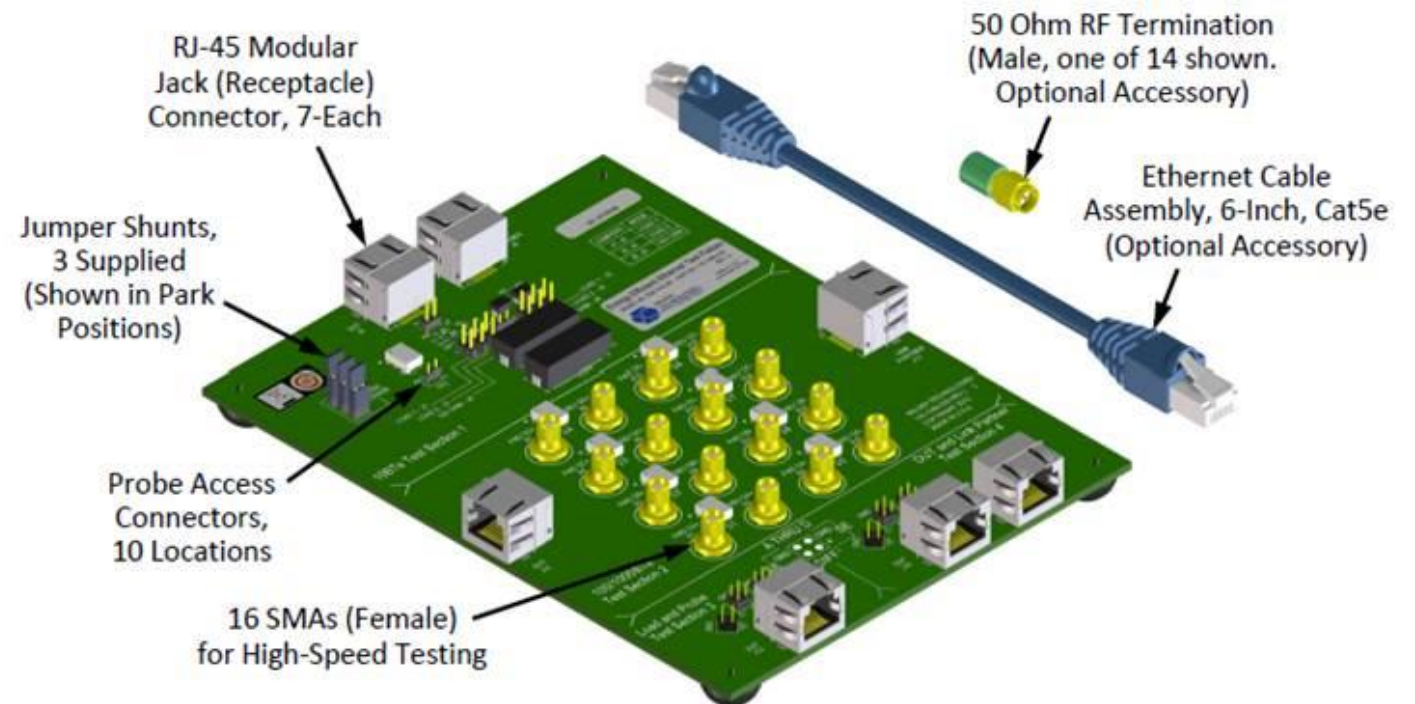

# Ethernet Compliance Testing with N5392A/B

The screenshot shows the software interface for Ethernet compliance testing. On the left, a 'Task Flow' sidebar contains buttons for 'Set Up', 'Select Tests', 'Configure', 'Connect', and 'Run Tests'. The main window has a menu bar with 'Set Up', 'Select Tests', 'Configure', 'Connect', 'Run Tests', 'Automation', 'Results', and 'Html Report'. The 'Set Up' section is expanded, showing 'Ethernet Speed' with checkboxes for 10Base-T, 100Base-T, 1000Base-T, 10Base-T-EEE, 100Base-T-EEE, and 1000Base-T-EEE. Below this, the '1000Base-T' section is highlighted with a red box and contains options for 'Use Disturbing Signal' (checked) and 'With TX\_TCLK' (checked). The 'Source' options include 'Use Keysight 33250A', 'Use Keysight 33612A', 'Use Keysight 81150/60/80A', and 'Use Others' (selected). The 'Return Loss Test' section is also highlighted with a red box and shows 'Use Vector Network Analyzer' (selected) and 'Use Data File' (unselected). The 'External Instruments' section shows a status of 'Not configured' and a 'Configure...' button. The 'Test Report Comments (Optional)' section is a large empty text area. Three callout boxes provide instructions: the top one points to the Ethernet Speed checkboxes, the middle one points to the 1000Base-T configuration options, and the bottom one points to the Return Loss Test options.

Pick the standards you want to test including Energy Efficient Ethernet

Setup your disturbing signal sources for Gigabit Ethernet testing

Make accurate return loss measurements with an Keysight Vector Network Analyzer

# Supported Tests 10BASE-T

Standard reference	Description
IEEE802.3.2005 Sub clause 14.3.1.2.1, Figure 14-12	Template Link Pulse with TPM
IEEE802.3.2005 Sub clause 14.3.1.2.1, Figure 14-12	Template Link Pulse without TPM
IEEE802.3.2005 Sub clause 14.3.1.2.1	Harmonic content
IEEE802.3.2005 Sub clause 14.3.1.2.1, Figure 14-9, Table 14-1	Template MAU
IEEE802.3.2005 Sub clause 14.3.1.2.1, Figure 14-10	Template TP_IDL with TPM
IEEE802.3.2005 Sub clause 14.3.1.2.1, Figure 14-10	Template TP_IDL without TPM
ANSI X3.263-1995, Section 9.1.3	Peak differential output voltage
IEEE802.3.2005 Sub clause 14.3.1.2.1 and Annex B.4.1 and B.4.3.3	Jitter with TPM
IEEE802.3.2005 Sub clause 14.3.1.2.1 and Annex B.4.1 and B.4.3.3	Jitter without TPM
IEEE802.3-2005 Sub clause 14.3.1.2.5	Common mode output voltage
IEEE802.3.2005 Sub clause 14.3.1.2.2 and Annex B.4.3.2	Transmitter Return Loss
IEEE802.3.2005 Sub clause 14.3.1.3.4 and Annex B.4.3.5	Receiver Return Loss

Tests are filtered based on selections in the Setup screen.

Task Flow: Set Up, Select Tests, Configure, Connect, Run Tests

Test Selection Tree:

- All Ethernet Tests
  - 10 Base-T
    - Measurements with TPM
      - Templates
        - Link Test Pulse, with TPM
        - TP\_IDL Template, with TPM (last bit CD0)
        - TP\_IDL Template, with TPM (last bit CD1)
        - MAU Template
      - Parametric
        - Jitter with TPM
    - Measurements without TPM
      - Templates
        - Link Test Pulse, without TPM
        - TP\_IDL Template, without TPM (last bit CD0)
        - TP\_IDL Template, without TPM (last bit CD1)
      - Parametric
        - Jitter without TPM
        - Peak Differential Voltage
        - Harmonic Content
    - Common Mode Voltage
      - Common Mode Output Voltage
    - Return Loss
      - Transmitter Return Loss
      - Receiver Return Loss

Test: 10 Base-T, Link Test Pulse, with TPM

Pass Limits: No Mask Failures  
 Description: The link test pulse shall be a single positive pulse which falls within the shaded area of Figure 14-12  
 Reference: IEEE802.3-2008 Subclause 14.3.1.2.1, Figure 14-12

=== Margin Formula: ===  
 If Actual = Required: Margin = 100%  
 If Actual <> Required AND Required <> 0: Margin = 0 - ( | Actual - Required | / Required ) \* 100%  
 If Actual <> Required AND Required = 0: Margin = 0 - | Actual | \* 100%

# Supported Tests 100BASE-TX

Standard reference	Description
ANSI X3.263-1995, Section 9.1.3	+V <sub>out</sub> overshoot
ANSI X3.263-1995, Section 9.1.3	+V <sub>out</sub> overshoot decay
ANSI X3.263-1995, Section 9.1.3	-V <sub>out</sub> overshoot
ANSI X3.263-1995, Section 9.1.3	-V <sub>out</sub> overshoot decay
ANSI X3.263-1995, Section 9.1.6	AOI +V <sub>out</sub> rise time
ANSI X3.263-1995, Section 9.1.6	AOI +V <sub>out</sub> rall time
ANSI X3.263-1995, Section 9.1.6	AOI +V <sub>out</sub> rise/fall time symmetry
ANSI X3.263-1995, Section 9.1.6	AOI -V <sub>out</sub> rise time
ANSI X3.263-1995, Section 9.1.6	AOI -V <sub>out</sub> fall time
ANSI X3.263-1995, Section 9.1.6	AOI -V <sub>out</sub> rise/fall time symmetry
ANSI X3.263-1995, Section 9.1.8	Duty cycle distortion
ANSI X3.263-1995, Section 9.1.4	Signal amplitude symmetry
ANSI X3.263-1995, Section 9.1.9 & IEEE802.3-2005 Sub clause 25.4.5	Transmit jitter
ANSI X3.263-1995, Annex J	UTP AOI template
ANSI X3.263-1995, Section 9.1.2.2	UTP +V <sub>out</sub> differential output voltage
ANSI X3.263-1995, Section 9.1.2.2	UTP -V <sub>out</sub> differential output voltage
ANSI X3.263-1995, Section 9.1.5	Transmitter Return Loss
ANSI X3.263-1995, Section 9.2.2	Receiver Return Loss

Tests are filtered based on selections in the Setup screen.

File View Tools Help

Task Flow: Set Up, Select Tests, Configure, Connect, Run Tests

Automation Results Html Report

100 Base-TX

- Peak Voltage
  - UTP +Vout Differential Output Voltage
  - UTP -Vout Differential Output Voltage
  - UTP Signal Amplitude Symmetry
- Overshoot
  - +Vout Overshoot
  - Vout Overshoot
- Template
  - UTP AOI Template
- Rise and Fall Time
  - AOI +Vout Rise Time
  - AOI +Vout Fall Time
  - AOI +Vout Rise/Fall Symmetry
  - AOI -Vout Rise Time
  - AOI -Vout Fall Time
  - AOI -Vout Rise/Fall Symmetry
  - AOI Overall Rise/Fall Symmetry
- DCD/Jitter
  - Transmit Jitter
  - Duty Cycle Distortion
- Return Loss
  - Transmitter Return Loss
  - Receiver Return Loss

**Test: 100 Base-TX, UTP +Vout Differential Output Voltage**

Pass Limits: 950.0 mV < +Vout < 1.0500 V  
 Description: Vout is defined as the straight line best fit for amplitude. Here, Vout is measured over a 96ns pulse.  
 Reference: ANSI X3.263-1995, Section 9.1.2.2

=== Margin Formula: ===  
 If Actual <= Range Midpoint: Margin = (( Actual - Min ) / Range ) \* 100%  
 If Actual > Range Midpoint: Margin = (( Max - Actual ) / Range ) \* 100%

# Supported Tests 1000BASE-T

Standard reference	Description
IEEE802.3.2005 Sub clause 40.6.1.2.1	Difference A, B peak output voltage*
IEEE802.3.2005 Sub clause 40.6.1.2.1	Point A peak output voltage*
IEEE802.3.2005 Sub clause 40.6.1.2.3	Point A template test*
IEEE802.3.2005 Sub clause 40.6.1.2.1	Point B peak output voltage*
IEEE802.3.2005 Sub clause 40.6.1.2.3	Point B template test*
IEEE802.3.2005 Sub clause 40.6.1.2.1	Point C peak output voltage*
IEEE802.3.2005 Sub clause 40.6.1.2.3	Point C template test*
IEEE802.3.2005 Sub clause 40.6.1.2.1	Point D peak output voltage*
IEEE802.3.2005 Sub clause 40.6.1.2.3	Point D template test*
IEEE802.3.2005 Sub clause 40.6.1.2.3	Point F template test*
IEEE802.3.2005 Sub clause 40.6.1.2.2	Point G droop test*
IEEE802.3.2005 Sub clause 40.6.1.2.3	Point H template test*
IEEE802.3.2005 Sub clause 40.6.1.2.2	Point J droop test*
IEEE802.3-2005 Sub clause 40.8.3.3	MDI common mode output voltage
IEEE802.3-2005 Sub clause 40.6.1.2.5	Jitter master filtered
IEEE802.3-2005 Sub clause 40.6.1.2.5	Jitter master unfiltered
IEEE802.3-2005 Sub clause 40.6.1.2.5	Jitter slave filtered
IEEE802.3-2005 Sub clause 40.6.1.2.5	Jitter slave filtered
IEEE802.3-2005 Sub clause 40.8.3.1	MDI Return Loss
IEEE802.3-2005 Sub clause 40.6.1.2.4	Transmitter Distortion*

Tests are filtered based on selections in the Setup screen.

File View Tools Help

Task Flow: Set Up, Select Tests, Configure, Connect, Run Tests

Test Selection Tree:

- All Ethernet Tests
  - 1000 Base-T
    - Test Mode 1 Signal Tests (With Disturbing Signal)
      - Peak Voltage
      - Templates
      - Droop
        - Point G
        - Point J
    - Test Mode 4 Signal Tests (With Disturbing Signal)
      - Transmitter Distortion
    - Common Mode Voltage
      - MDI Common Mode Output Voltage
    - Jitter With TX-TCLK
      - DUT in MASTER Mode
      - DUT in SLAVE Mode
    - Return Loss
      - MDI Return Loss
  - 100 Base-TX
    - Peak Voltage
      - UTP +Vout Differential Output Voltage
      - UTP -Vout Differential Output Voltage
      - UTP Signal Amplitude Symmetry
    - Overshoot
      - +Vout Overshoot
      - Vout Overshoot
    - Template
      - UTP AOI Template
    - Rise and FallTime
    - DCD/Jitter
    - Return Loss

Test: 100 Base-TX, +Vout Overshoot

Pass Limits: +Overshoot (%) < 5.0 %

Description: We define overshoot as the percentage difference between the peak voltage of the signal between the 50% transition crossing time from 0 to VOut and a point in time 8ns afterward. Over Reference: ANSI X3.263-1995, Section 9.1.3

# Running Tests with the N5392B

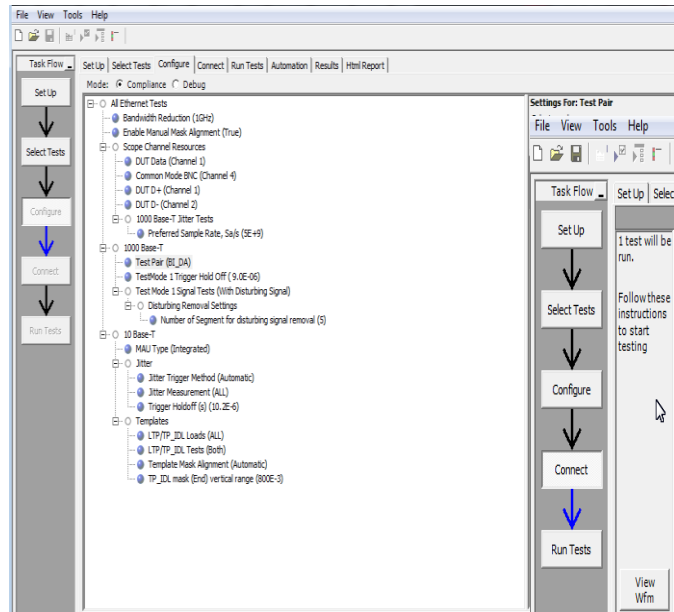

After selecting tests, use the configure page to make any changes to your configuration if necessary.

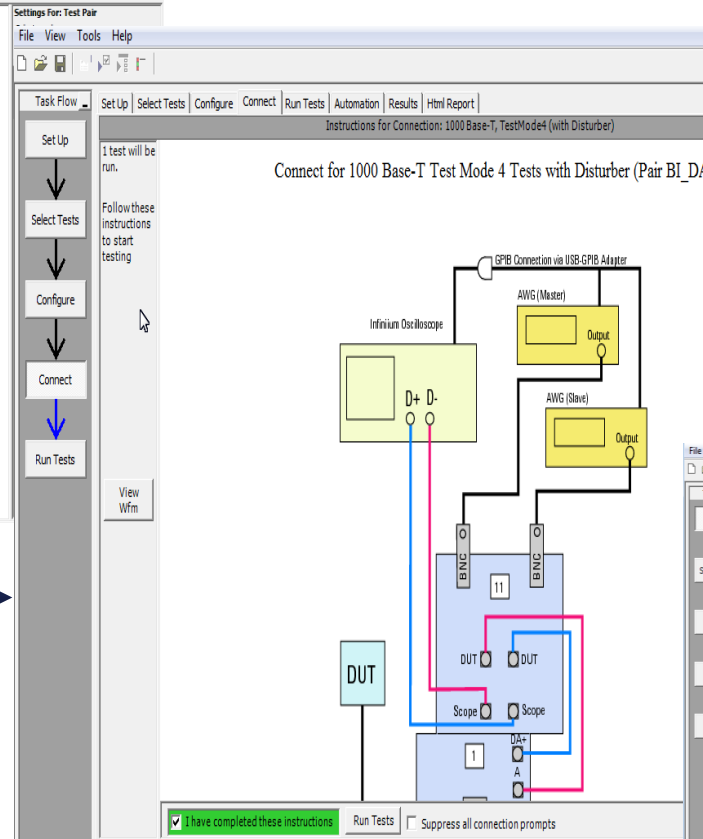

When you make multiple tests where the connections must be changed, you will be prompted with detailed connection diagrams.

Connect for 1000 Base-T Test Mode 4 Tests with Disturber (Pair BI\_DA)

The results page displays more than just results, giving you details from specs, measured values, waveforms, and margin analysis.

Test Name	Worst Actual	Worst Margin	Pass Limits
1000 Base-T, Point A Peak Output Voltage(v/o Disturbing Signal)	720.1 mV	33.4%	670.0 mV < VALUE < 820.0 mV
1000 Base-T, Point B Peak Output Voltage(v/o Disturbing Signal)	716.2 mV	30.8%	670.0 mV < (VALUE) < 820.0 mV
1000 Base-T, Difference A-B Peak Output Voltage(v/o Disturbing Signal)	940 m% <sup>2</sup>	46.0%	VALUE < 1.00 %
1000 Base-T, Point C Peak Output Voltage(v/o Disturbing Signal)	330 m% <sup>2</sup>	63.3%	(VALUE) < 2.00 %
1000 Base-T, Point D Peak Output Voltage(v/o Disturbing Signal)	1.10 %	45.0%	(VALUE) < 2.00 %
1000 Base-T, Point A Template Test(v/o Disturbing Signal)	0.000	100.0%	No Mask Failures
1000 Base-T, Point B Template Test(v/o Disturbing Signal)	0.000	100.0%	No Mask Failures
1000 Base-T, Point C Template Test(v/o Disturbing Signal)	0.000	100.0%	No Mask Failures
1000 Base-T, Point D Template Test(v/o Disturbing Signal)	0.000	100.0%	No Mask Failures
1000 Base-T, Point F Template Test(v/o Disturbing Signal)	0.000	100.0%	No Mask Failures
1000 Base-T, Point H Template Test(v/o Disturbing Signal)	0.000	100.0%	No Mask Failures
1000 Base-T, Point G Droop Test(v/o Disturbing Signal)	95.98 %	31.3%	VALUE > 73.10 %
1000 Base-T, Point J Droop Test(v/o Disturbing Signal)	95.53 %	30.7%	VALUE > 73.10 %
1000 Base-T, Transmitter Distortion(v/o Disturbing Signal)	11.44 mV	58.4%	VALUE <= 10.00 mV
100 Base-TX, UTP -Vout Differential Output Voltage	1.0238 V	26.4%	950.0 mV < VALUE < 1.0500 V
100 Base-TX, UTP -Vout Differential Output Voltage	-1.0303 V	0.0%	950.0 mV < (VALUE) < 1.0500 V
100 Base-TX, UTP Signal Amplitude Symmetry	-975 m	12.5%	980 m < (VALUE) < 1.020
100 Base-TX, +Vout Overshoot	-2.2 %	144.0%	VALUE < 5.0 %
100 Base-TX, -Vout Overshoot	-1.2 %	124.0%	VALUE < 5.0 %
100 Base-TX, UTP ACI Template	0.000	100.0%	No Mask Failures

Details: 1000 Base-T, MDI Common Mode Output Voltage

Parameter	Value	Reference Limits
Pass Limits	< 50.0 mV	
Parameter Tested	MDI Common Mode Voltage	
Actual Value	21.6 mV	
Reference Limits		
Maximum Peak	10.3 mV	
Minimum Peak	-11.3 mV	
Time Range Measured	10.0 ms	
Test Pair	BI_DA	

# N5392B HTML Report



## Ethernet Test Report

Overall Result: **FAIL**

Test Configuration Details	
Device Description	
ReturnLossTest	Use Data File
DisturberSource	Use Agilent 33250A
Test Session Details	
Infinium SW Version	05.20.0021
Infinium Model Number	DS091304A
Infinium Serial Number	No Serial
Application SW Version	2.42.9013
Debug Mode Used	No
Probe (Channel 1)	Model: 1134A Serial: US42002914 Head: E2676A Atten: Not Calibrated, Using Default Atten (1.0000E+001) Skew: Not Calibrated, Using Default Skew
Last Test Date	2015-02-24 03:20:44 UTC -07:00

### Summary of Results

Test Statistics	
Failed	5
Passed	37
Total	42

The N5392B Ethernet test application automatically generates detailed HTML reports that is suitable for archiving or sharing with customers or colleagues.

Additional details are available for each test, including description, limits, results, and waveforms.



# N5392B 10/100/1000Base-T Ethernet Compliance

- Setup wizard for quick and clear setup, configuration and test
- Wide range of 1000BASE-T, 100BASE-TX and 10BASE-T tests enabling standards conformance
- Disturbing signal support for 1000BASE-T Test Mode 1 and 4 tests
- Accurate and repeatable results with Keysight Infiniium oscilloscopes
- Accurate return loss measurements with supported Keysight vector network analyzers
- Automated reporting in a comprehensive HTML format with margin analysis

# EEE tests covering 10/100/1000 Base-T

Test coverage as per Energy Efficient Ethernet Test Specification (802.3az-2010) for 10/100/1000BT.

**Consists of the following 31 tests:**

## **10Base-Te Tests: 14**

LTP, with/without TPM  
TP\_IDL, with/without TPM (CD0, CD1)  
MAU Template  
Jitter, with/without TPM  
Peak Differential Voltage  
Harmonic Content  
Common Mode Output Voltage  
Transmitter Return Loss  
Receiver Return Loss

\*Moved to debug because most customers find these tests difficult to setup.

\*\*New added tests

## **100Base-Te Tests: 5**

Quiet Time  
Refresh Time  
Sleep Time  
Transmit Wake Time  
Transmitter Timing Jitter

## **1000Base-Te: 9**

\*Sleep Time (Master/Slave)  
Quite Time  
Refresh Time (Master/Slave)  
Transmit Wake Time (Master/Slave)  
\*Wake State Levels  
Transmitter Timing Jitter  
\*\*Waketx Time  
\*\*Waketx Full  
\*\*Wakemz

# 10BASE-Te:

- List of tests same as 10Base-T

## 10Base-T:

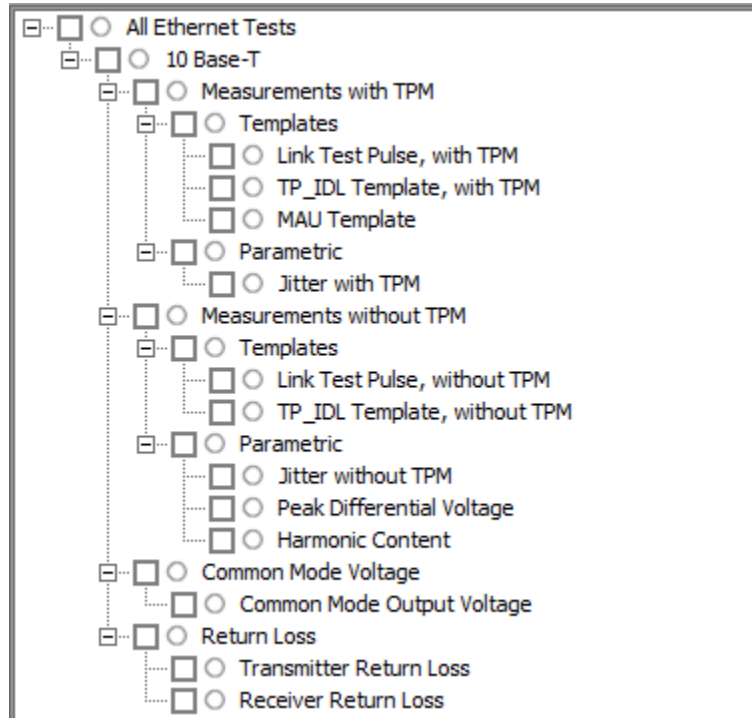

## 10Base-Te:

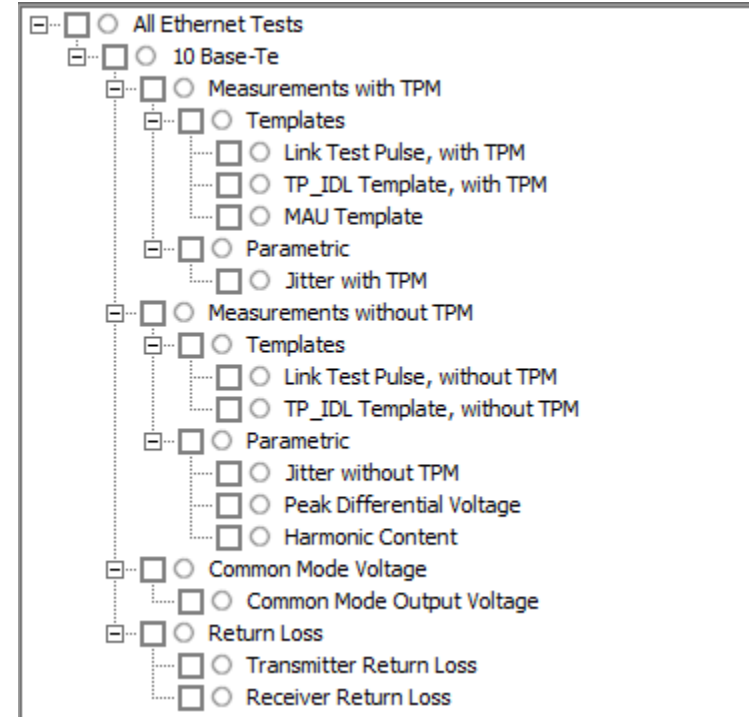

# 10BASE-Te:

- Only difference: For tests **with TPM**, use new fixture. Probe at TP1.

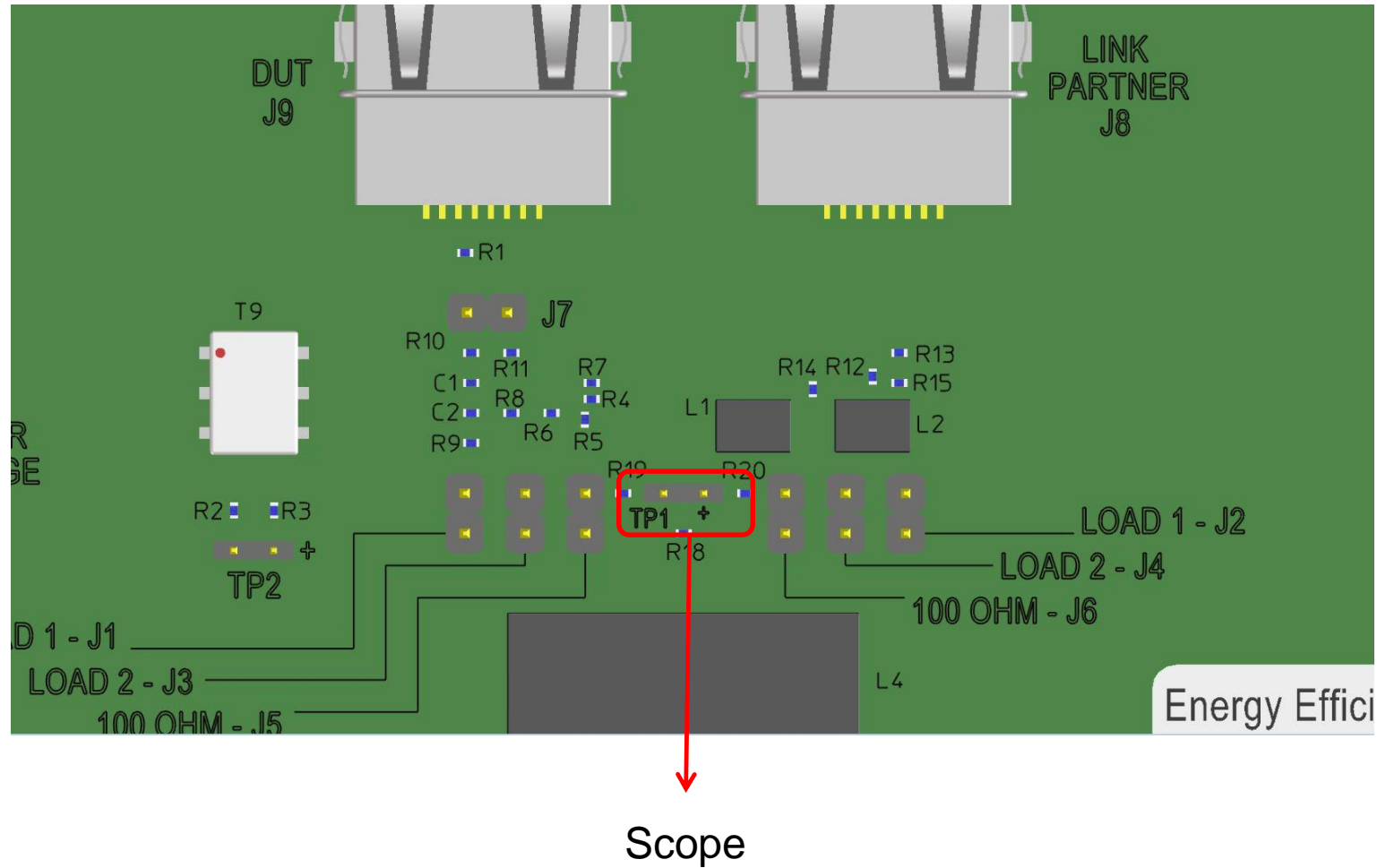

# 100BASE-TX (EEE):

100Base-TX Connection:

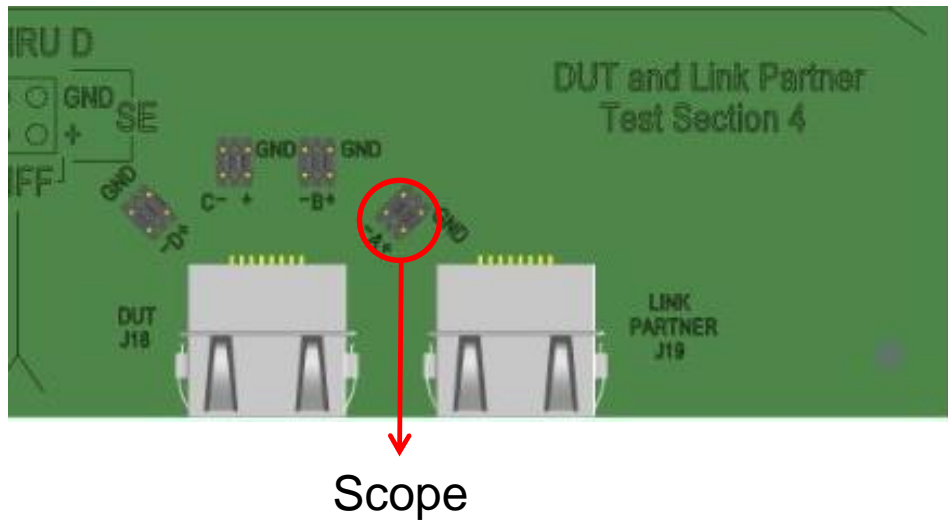

100Base-TX Signal:

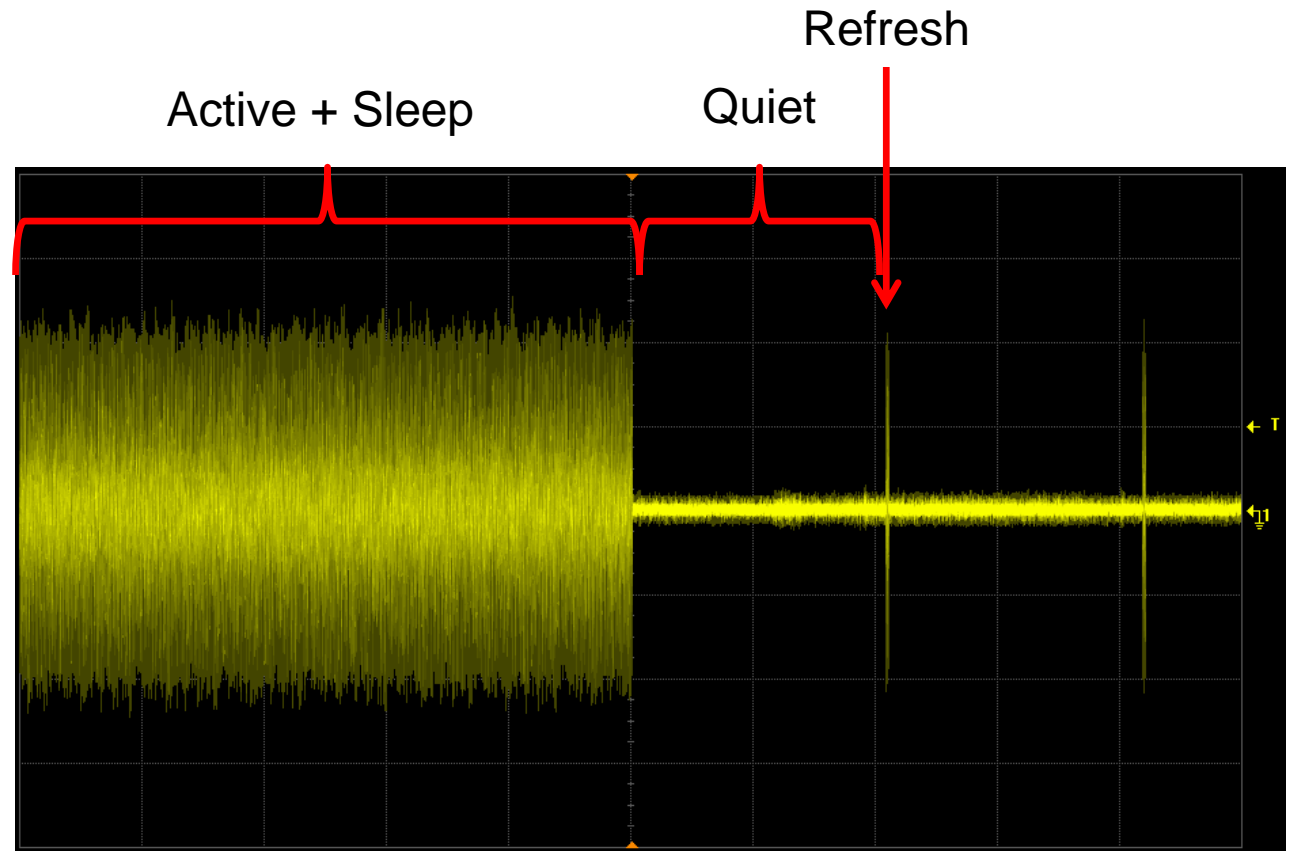

# 1000BASE-T (EEE):

1000Base-T Connection:

1000Base-T Signal:

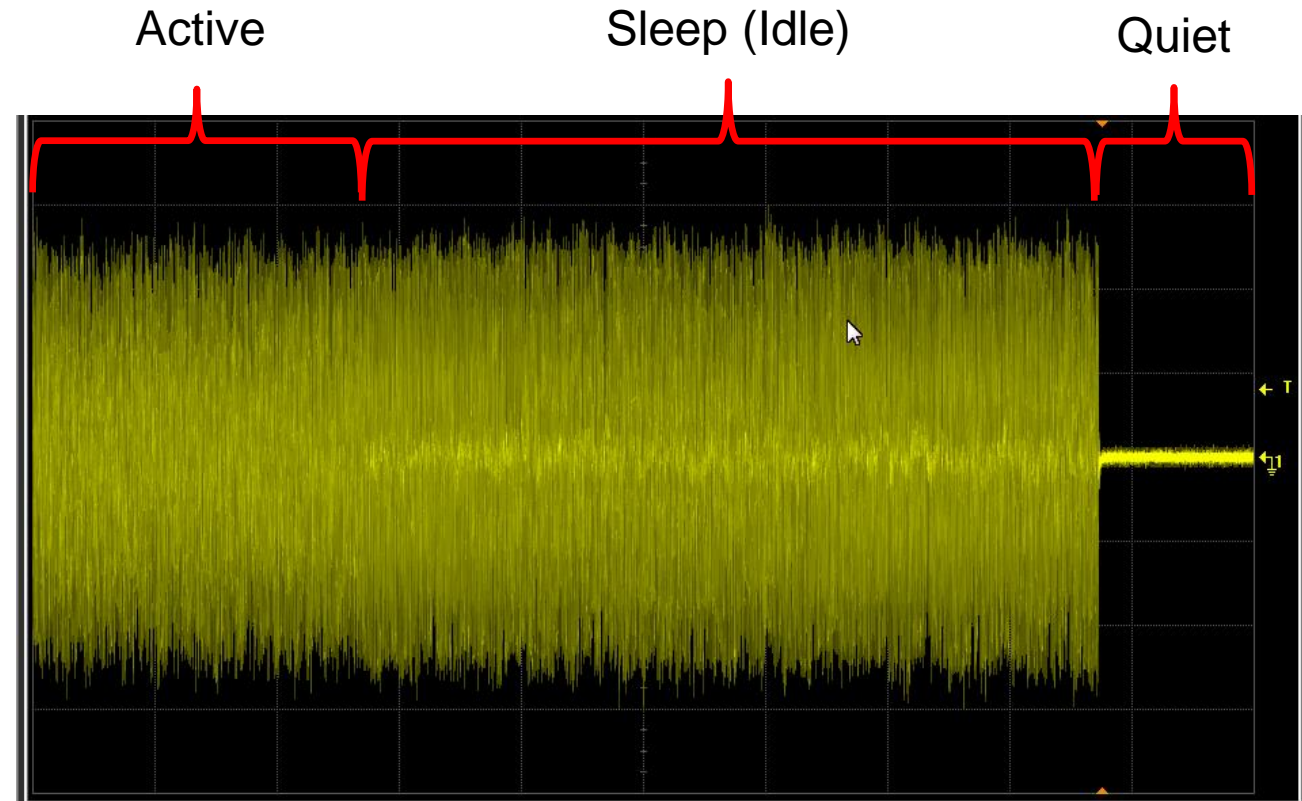
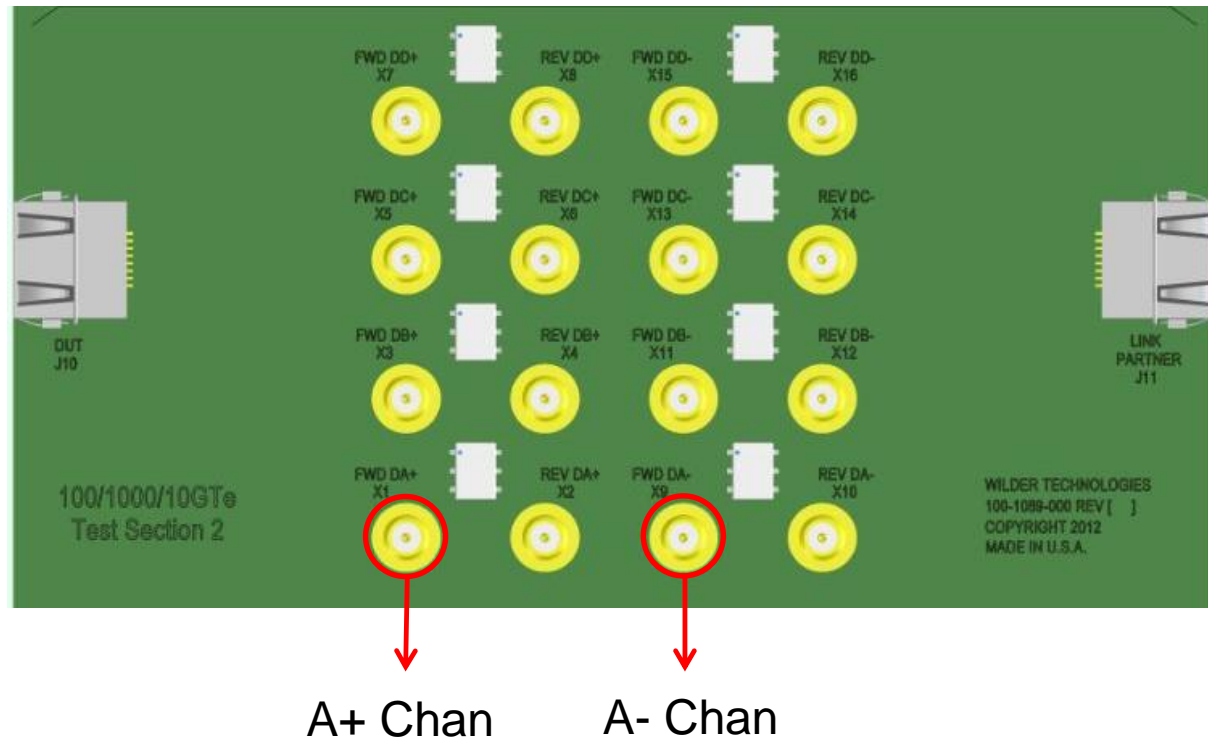

# 100Base-TX / 1000Base-T (EEE):

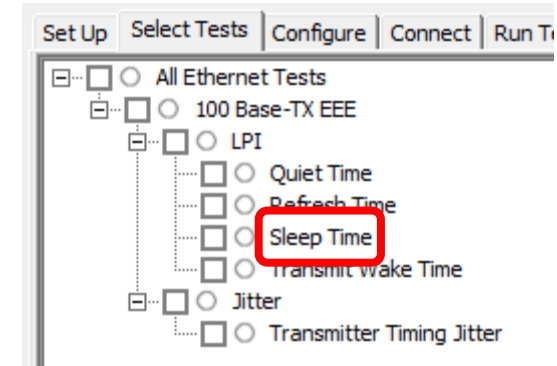
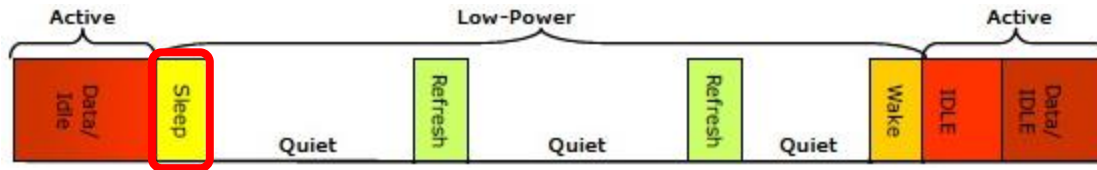

- Sleep Time (100Base-TX and 1000Base-T)
  1. Initiate transmission between DUT and LP
  2. Force DUT into Low Power Idle (LPI) to capture 1 cycle of sleep pattern
  3. Repeat 1 and 2 for multiple captures

# 100Base-TX / 1000Base-T (EEE):

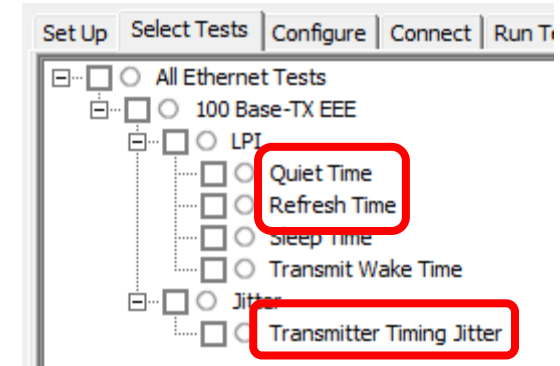
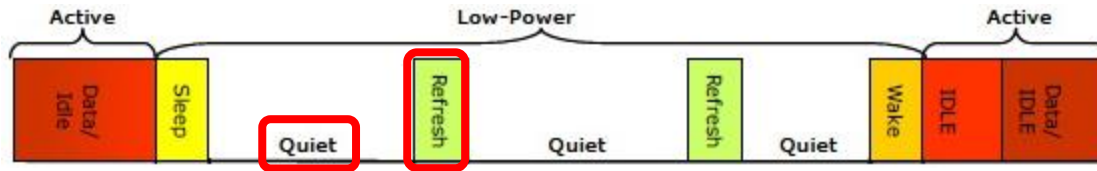

- Quiet Time / Refresh Time / Transmitter Timing Jitter (100Base-TX and 1000Base-T)

1. Put the DUT into LPI mode

# 100Base-TX / 1000Base-T (EEE):

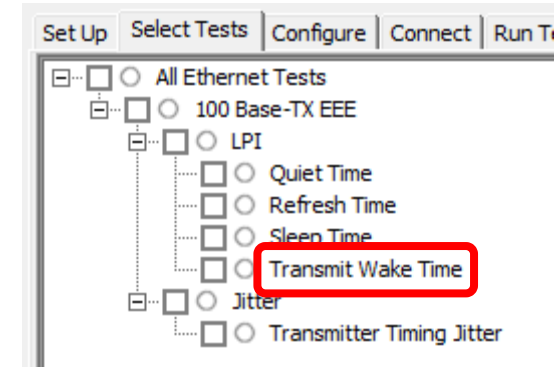
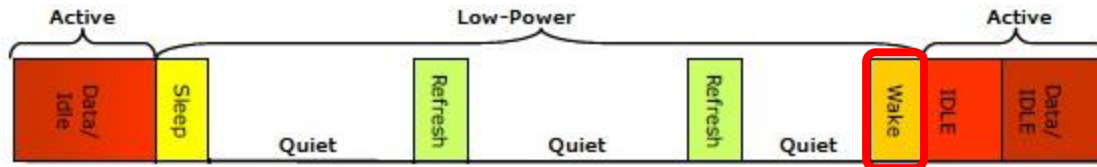

- Transmit Wake Time (100Base-TX and 1000Base-T)
  1. Ensure that the DUT is in LPI mode
  2. Force the DUT to “wake up” from LPI by beginning transmission

# 100Base-TX / 1000Base-T (EEE):

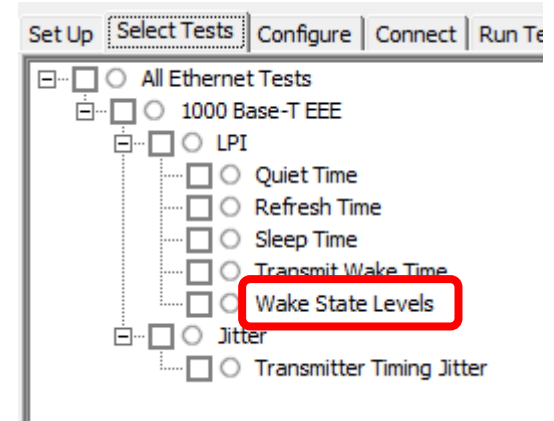
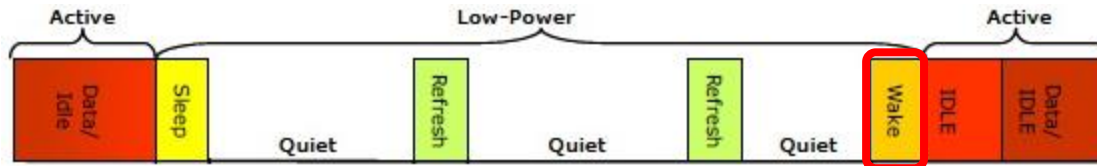

- Wake State Levels (1000Base-T Only)
  1. Ensure that the DUT is in LPI mode
  2. Force the DUT to “wake up” from LPI by beginning transmission



# Ethernet Decoder Highlights

Gain greater insight from your design

## Go Beyond Raw Waveforms

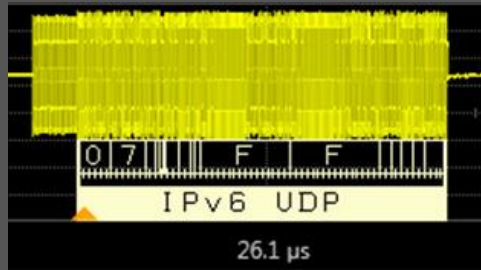

- Time correlated waveform with decode
- Quick one-button setup
- Simultaneous Transmit and Receive Decode
- IPv6

## Trigger and Search Ethernet Packets

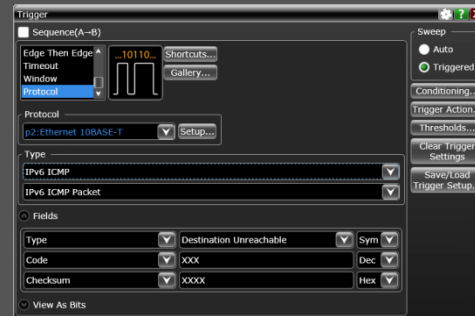

- Trigger/Search on packet errors
- Trigger/Search on specific packets

## View Packets the way you want to see them

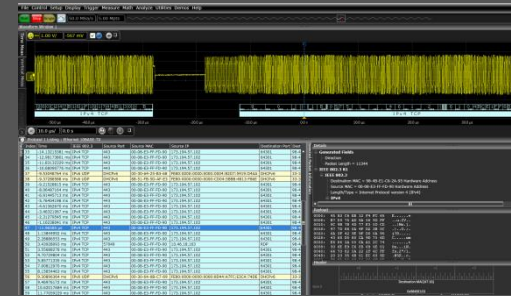

- View as waveform with decode
- View packets in lister format
- View packet details
- Offline capability

# Ethernet Decoder OSI Model and Setup...

## OSI Model Layers

Application  
Presentation  
Session

Ethernet  
Client A

Transport

TCP

Network

IPv4/IPv6

Data Link

10Base-T or  
100Base-TX

Physical



DSO8054A Oscilloscope  
Ethernet Protocol Decoder

Ethernet  
Client B

TCP

IPv4/IPv6

10Base-T or  
100Base-TX

Two twisted pair wire (TX, RX)

### Definitions:

OSI – Open Systems Interconnect

TCP – Transmission Control Protocol

IPv4 or IPv6 – Internet Protocol version 4 or 6

Link – Ethernet 10BASE-T or 100BASE-TX

# Ethernet Decoder Hardware Setup...

Use the scope or Laptop as the device under test.  
Laptop is better if you want to avoid flipping back and forth between the scope GUI and the traffic generators.

PINOUT	SIGNAL	EIA/TIA 568B or AT&T 258A cable colors
PIN 1	TX+	White with orange stripe
PIN 2	TX-	Orange with white stripe or solid orange
PIN 3	RX+	White with green stripe
PIN 4	NC	Blue with white stripe or solid blue
PIN 5	NC	White with blue stripe
PIN 6	RX-	Green with white stripe or solid green
PIN 7	NC	White with brown stripe
PIN 8	NC	Brown with white stripe or solid brown

PINOUT	SIGNAL	Wire Color
PIN 1	TX+	White with Orange stripe
PIN 2	TX-	Solid Orange
PIN 3	RX+	White with Green stripe
PIN 6	RX-	Solid Blue

All other pins are no connect

Note: Ethernet Protocol Decoder is available in demo center – no hardware required.

## Ethernet Protocol Decoder



Differential Probe      Differential Probe

TX+    TX-    RX+    RX-  
PIN 1    2    3    6

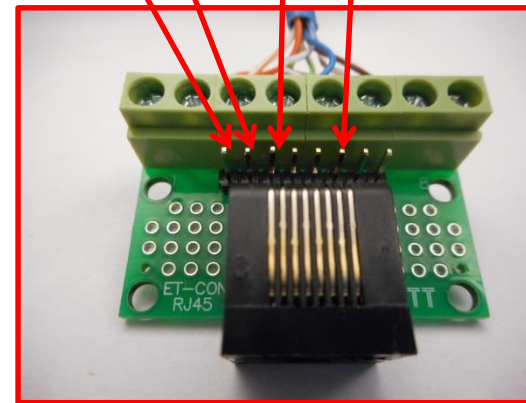
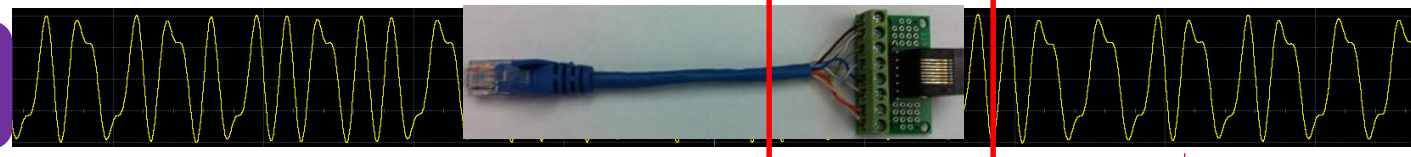

Image rotated 90 degrees

Internet



Two twisted pair wire (TX, RX)

# Correlated markers of trace data and packets

- Blue line marker shows correlation between trace and packet data (raw data).
- Fully decoded packets

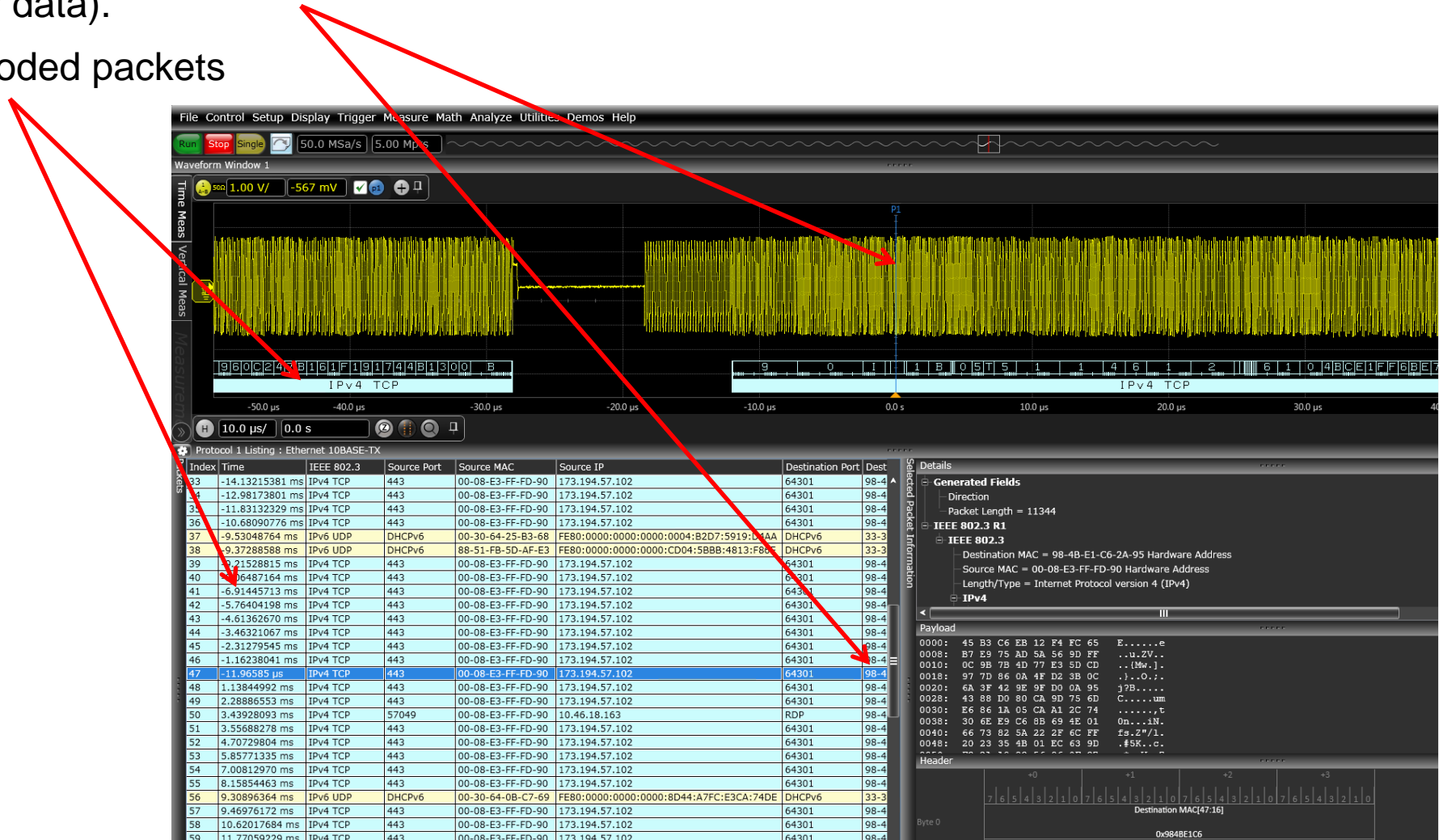

# Simultaneous Transmit and Receive decode...

- Transmit and receive waveform data (raw data) and packet data decode can be displayed simultaneously in one viewer.

The screenshot displays the Keysight Oscilloscope software interface. The top menu includes File, Control, Setup, Display, Trigger, Measure, Math, Analyze, Utilities, Demos, and Help. The main window is titled 'Waveform Window 1' and shows two waveforms: a yellow transmit waveform and a green receive waveform. The transmit waveform is labeled 'Transmit waveform and decode' with a yellow arrow. The receive waveform is labeled 'Receive waveform and decode' with a green arrow. Below the waveforms, there are two protocol listings for Ethernet 10BASE-T. The first listing shows five packets, and the second listing shows eight packets. The right side of the interface displays details for the selected packet, including Destination MAC, Payload, and Header.

Transmit waveform and decode

Receive waveform and decode

Index	Time	IEEE 802.3	Source Port	Source MAC	Source IP
1	-4.60221016 ms	IPv4 TCP	443	00-08-E3-FF-FD-90	173.194.141.1
2	-3.37179310 ms	IPv4 TCP	443	00-08-E3-FF-FD-90	173.194.141.1
3	-2.14137550 ms	IPv4 TCP	443	00-08-E3-FF-FD-90	173.194.141.1
4	-1.41336609 ms	IPv4 TCP	443	00-08-E3-FF-FD-90	173.194.141.1
5	-182.95013 $\mu$ s	IPv4 TCP	443	00-08-E3-FF-FD-90	173.194.141.1

Index	Time	IEEE 802.3	Source Port	Source MAC	Source IP	Destination Port	De
1	-4.18847436 ms	IPv4 TCP	58591	98-4B-E1-C6-2A-95	141.121.237.191	443	00
2	-3.16551816 ms	IPv4 TCP	58591	98-4B-E1-C6-2A-95	141.121.237.191	443	00
3	-1.77043144 ms	IPv4 TCP	58591	98-4B-E1-C6-2A-95	141.121.237.191	443	00
4	-1.25856305 ms	IPv4 TCP	58591	98-4B-E1-C6-2A-95	141.121.237.191	443	00
5	-11.97045 $\mu$ s	IPv4 TCP	58591	98-4B-E1-C6-2A-95	141.121.237.191	443	00
6	1.26777884 ms	IPv4 TCP	58591	98-4B-E1-C6-2A-95	141.121.237.191	443	00
7	1.78046776 ms	IPv4 TCP	58591	98-4B-E1-C6-2A-95	141.121.237.191	443	00
8	3.04124512 ms	IPv4 TCP	58591	98-4B-E1-C6-2A-95	141.121.237.191	443	00

# Protocol Listing - Expanded packet view ...

- Packets are color coded so that packet types can be quickly identified.
- Dark blue packet is current packet that aligns with the trace
- In this window we see IPv4 TCP packets in light blue and IPv6 UDP packets in brown.

Index	Time	IEEE 802.3	Source Port	Source MAC	Source IP	Destination Port	Destination MAC	Destination IP	FCS CRC	Checksum
31	-16.43298496 ms	IPv4 TCP	443	00-08-E3-FF-FD-90	173.194.57.102	64301	98-4B-E1-C6-2A-95	141.121.237.191	E5F5 CDF0 (GOOD)	F5CB (GOOD)
32	-15.28256957 ms	IPv4 TCP	443	00-08-E3-FF-FD-90	173.194.57.102	64301	98-4B-E1-C6-2A-95	141.121.237.191	526D EC8E (GOOD)	CEBC (GOOD)
33	-14.13215381 ms	IPv4 TCP	443	00-08-E3-FF-FD-90	173.194.57.102	64301	98-4B-E1-C6-2A-95	141.121.237.191	F657 C7E8 (GOOD)	53FB (GOOD)
34	-12.98173801 ms	IPv4 TCP	443	00-08-E3-FF-FD-90	173.194.57.102	64301	98-4B-E1-C6-2A-95	141.121.237.191	5132 68EF (GOOD)	CF9F (GOOD)
35	-11.83132329 ms	IPv4 TCP	443	00-08-E3-FF-FD-90	173.194.57.102	64301	98-4B-E1-C6-2A-95	141.121.237.191	8EDD 89A1 (GOOD)	D463 (GOOD)
36	-10.68090776 ms	IPv4 TCP	443	00-08-E3-FF-FD-90	173.194.57.102	64301	98-4B-E1-C6-2A-95	141.121.237.191	C94D 403B (GOOD)	FDA7 (GOOD)
37	-9.53048764 ms	IPv6 UDP	DHCPv6	00-30-64-25-B3-68	FE80:0000:0000:0000:0004:B2D7:5919:D4AA	DHCPv6	33-33-00-01-00-02	FF02:0000:0000:0000:0000:0000:0001:0002	0771 CDF9 (GOOD)	D343 (GOOD)
38	-9.37288588 ms	IPv6 UDP	DHCPv6	88-51-FB-5D-AF-E3	FE80:0000:0000:0000:CD04:58BB:4813:F86E	DHCPv6	33-33-00-01-00-02	FF02:0000:0000:0000:0000:0000:0001:0002	F964 91A4 (GOOD)	DB73 (GOOD)
39	-9.21528815 ms	IPv4 TCP	443	00-08-E3-FF-FD-90	173.194.57.102	64301	98-4B-E1-C6-2A-95	141.121.237.191	4EEC F60A (GOOD)	D162 (GOOD)
40	-8.06487164 ms	IPv4 TCP	443	00-08-E3-FF-FD-90	173.194.57.102	64301	98-4B-E1-C6-2A-95	141.121.237.191	226F F094 (GOOD)	5375 (GOOD)
41	-6.91445713 ms	IPv4 TCP	443	00-08-E3-FF-FD-90	173.194.57.102	64301	98-4B-E1-C6-2A-95	141.121.237.191	9EBC 4275 (GOOD)	C224 (GOOD)
42	-5.76404198 ms	IPv4 TCP	443	00-08-E3-FF-FD-90	173.194.57.102	64301	98-4B-E1-C6-2A-95	141.121.237.191	6907 0DF1 (GOOD)	4997 (GOOD)
43	-4.61362670 ms	IPv4 TCP	443	00-08-E3-FF-FD-90	173.194.57.102	64301	98-4B-E1-C6-2A-95	141.121.237.191	3A47 30C9 (GOOD)	6095 (GOOD)
44	-3.46321067 ms	IPv4 TCP	443	00-08-E3-FF-FD-90	173.194.57.102	64301	98-4B-E1-C6-2A-95	141.121.237.191	2810 8AE6 (GOOD)	E38F (GOOD)
45	-2.31279545 ms	IPv4 TCP	443	00-08-E3-FF-FD-90	173.194.57.102	64301	98-4B-E1-C6-2A-95	141.121.237.191	9933 1BB3 (GOOD)	E885 (GOOD)
46	-1.16238041 ms	IPv4 TCP	443	00-08-E3-FF-FD-90	173.194.57.102	64301	98-4B-E1-C6-2A-95	141.121.237.191	B341 96DD (GOOD)	CEB9 (GOOD)
47	-1.196585 ps	IPv4 TCP	443	00-08-E3-FF-FD-90	173.194.57.102	64301	98-4B-E1-C6-2A-95	141.121.237.191	F460 8D78 (GOOD)	109C (GOOD)
48	1.13844992 ms	IPv4 TCP	443	00-08-E3-FF-FD-90	173.194.57.102	64301	98-4B-E1-C6-2A-95	141.121.237.191	0F32 C9AB (GOOD)	1312 (GOOD)
49	2.28886553 ms	IPv4 TCP	443	00-08-E3-FF-FD-90	173.194.57.102	64301	98-4B-E1-C6-2A-95	141.121.237.191	3014 1016 (GOOD)	FA94 (GOOD)
50	3.43928093 ms	IPv4 TCP	57049	00-08-E3-FF-FD-90	10.46.18.163	RDP	98-4B-E1-C6-2A-95	141.121.237.191	A07A 9C8F (GOOD)	EDB4 (GOOD)
51	3.55688278 ms	IPv4 TCP	443	00-08-E3-FF-FD-90	173.194.57.102	64301	98-4B-E1-C6-2A-95	141.121.237.191	55FF 090A (GOOD)	5A25 (GOOD)
52	4.70729804 ms	IPv4 TCP	443	00-08-E3-FF-FD-90	173.194.57.102	64301	98-4B-E1-C6-2A-95	141.121.237.191	30F3 2163 (GOOD)	2598 (GOOD)
53	5.85771335 ms	IPv4 TCP	443	00-08-E3-FF-FD-90	173.194.57.102	64301	98-4B-E1-C6-2A-95	141.121.237.191	9EEB 5149 (GOOD)	8FE5 (GOOD)
54	7.00812970 ms	IPv4 TCP	443	00-08-E3-FF-FD-90	173.194.57.102	64301	98-4B-E1-C6-2A-95	141.121.237.191	A34E EA4F (GOOD)	E650 (GOOD)
55	8.15854463 ms	IPv4 TCP	443	00-08-E3-FF-FD-90	173.194.57.102	64301	98-4B-E1-C6-2A-95	141.121.237.191	0C4E 69ED (GOOD)	583F (GOOD)
56	9.30896364 ms	IPv6 UDP	DHCPv6	00-30-64-0B-C7-69	FE80:0000:0000:0000:8D44:A7FC:E3CA:74DE	DHCPv6	33-33-00-01-00-02	FF02:0000:0000:0000:0000:0000:0001:0002	62EB B0FB (GOOD)	7CD4 (GOOD)
57	9.46976172 ms	IPv4 TCP	443	00-08-E3-FF-FD-90	173.194.57.102	64301	98-4B-E1-C6-2A-95	141.121.237.191	37F2 B84C (GOOD)	9B33 (GOOD)
58	10.62017684 ms	IPv4 TCP	443	00-08-E3-FF-FD-90	173.194.57.102	64301	98-4B-E1-C6-2A-95	141.121.237.191	EA4B 3403 (GOOD)	6BBE (GOOD)
59	11.77059229 ms	IPv4 TCP	443	00-08-E3-FF-FD-90	173.194.57.102	64301	98-4B-E1-C6-2A-95	141.121.237.191	E75B 7EBE (GOOD)	F43F (GOOD)
60	12.92100812 ms	IPv4 TCP	443	00-08-E3-FF-FD-90	173.194.57.102	64301	98-4B-E1-C6-2A-95	141.121.237.191	95C5 A8E8 (GOOD)	EC06 (GOOD)
61	14.071142410 ms	IPv4 TCP	443	00-08-E3-FF-FD-90	173.194.57.102	64301	98-4B-E1-C6-2A-95	141.121.237.191	5D86 3C1E (GOOD)	8B2A (GOOD)
62	15.22183913 ms	IPv4 TCP	443	00-08-E3-FF-FD-90	173.194.57.102	64301	98-4B-E1-C6-2A-95	141.121.237.191	647D A338 (GOOD)	D3E7 (GOOD)
63	16.37225393 ms	IPv4 TCP	443	00-08-E3-FF-FD-90	173.194.57.102	64301	98-4B-E1-C6-2A-95	141.121.237.191	A521 C5F4 (GOOD)	2196 (GOOD)
64	17.52266956 ms	IPv4 TCP	443	00-08-E3-FF-FD-90	173.194.57.102	64301	98-4B-E1-C6-2A-95	141.121.237.191	2B08 5D47 (GOOD)	6170 (GOOD)
65	18.67308510 ms	IPv4 TCP	443	00-08-E3-FF-FD-90	173.194.57.102	64301	98-4B-E1-C6-2A-95	141.121.237.191	B4A3 D0A2 (GOOD)	0C56 (GOOD)
66	19.82350008 ms	IPv4 TCP	443	00-08-E3-FF-FD-90	173.194.57.102	64301	98-4B-E1-C6-2A-95	141.121.237.191	0C23 6315 (GOOD)	9A57 (GOOD)
67	20.97391524 ms	IPv4 TCP	443	00-08-E3-FF-FD-90	173.194.57.102	64301	98-4B-E1-C6-2A-95	141.121.237.191	1C21 942C (GOOD)	70C4 (GOOD)
68	22.12433093 ms	IPv4 TCP	443	00-08-E3-FF-FD-90	173.194.57.102	64301	98-4B-E1-C6-2A-95	141.121.237.191	9C5D A511 (GOOD)	3C77 (GOOD)
69	23.27474667 ms	IPv4 TCP	443	00-08-E3-FF-FD-90	173.194.57.102	64301	98-4B-E1-C6-2A-95	141.121.237.191	A64F FACD (GOOD)	B092 (GOOD)
70	24.42516172 ms	IPv4 TCP	443	00-08-E3-FF-FD-90	173.194.57.102	64301	98-4B-E1-C6-2A-95	141.121.237.191	6C4D EBD5 (GOOD)	8769 (GOOD)
71	25.57557675 ms	IPv4 TCP	443	00-08-E3-FF-FD-90	173.194.57.102	64301	98-4B-E1-C6-2A-95	141.121.237.191	2CE7 26DB (GOOD)	B243 (GOOD)
72	26.72599218 ms	IPv4 TCP	443	00-08-E3-FF-FD-90	173.194.57.102	64301	98-4B-E1-C6-2A-95	141.121.237.191	D903 B655 (GOOD)	C5BB (GOOD)
73	27.87640864 ms	IPv4 TCP	443	00-08-E3-FF-FD-90	173.194.57.102	64301	98-4B-E1-C6-2A-95	141.121.237.191	6C26 DF90 (GOOD)	F0CC (GOOD)
74	29.02682357 ms	IPv4 TCP	443	00-08-E3-FF-FD-90	173.194.57.102	64301	98-4B-E1-C6-2A-95	141.121.237.191	8BE0 F9D5 (GOOD)	5A94 (GOOD)
75	30.17723865 ms	IPv4 TCP	443	00-08-E3-FF-FD-90	173.194.57.102	64301	98-4B-E1-C6-2A-95	141.121.237.191	172C AB2F (GOOD)	2BF4 (GOOD)
76	31.32765333 ms	IPv4 TCP	443	00-08-E3-FF-FD-90	173.194.57.102	64301	98-4B-E1-C6-2A-95	141.121.237.191	8826 D6D3 (GOOD)	5F85 (GOOD)

# Serial Decoder Setup

- Protocol decoder setup in the GUI

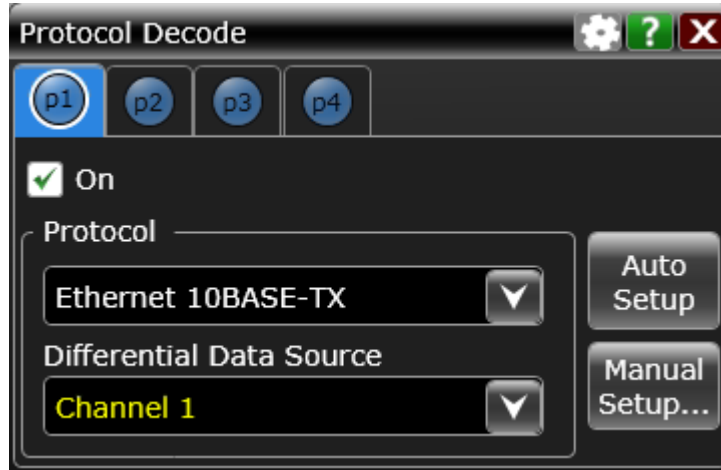

- Auto Setup allows the scope to detect and setup the threshold levels for you.

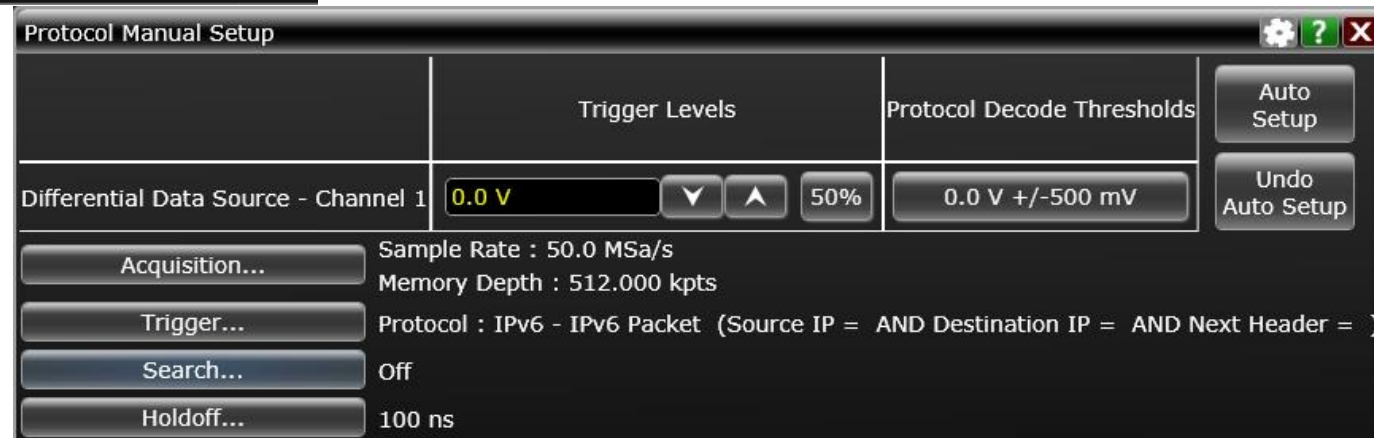

- In the manual setup window you can redefine the trigger levels and Protocol decode thresholds.

# Serial Decoder Search

- Must be selected to search data
- Search for specific packets or errors in the data

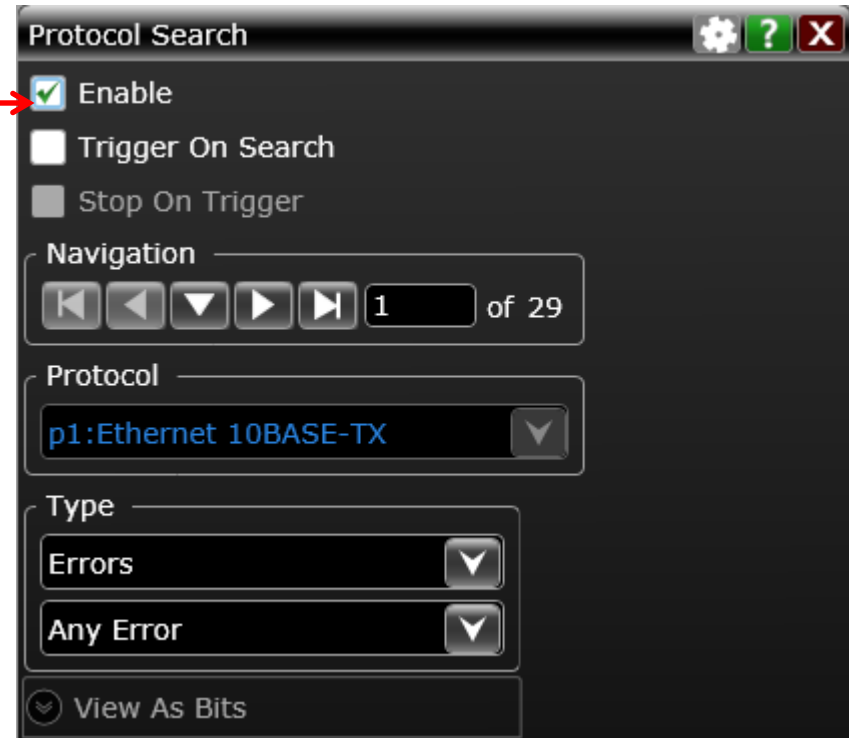
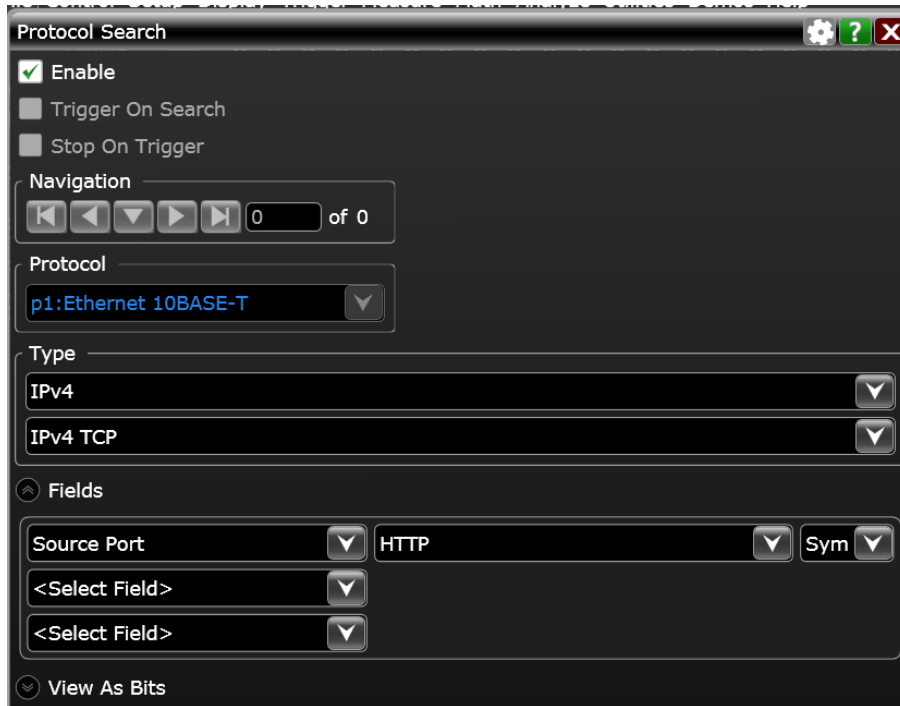

# 100BASE-TX

## Ethernet Cable Test Solution Overview

Using the E5071C ENA Option TDR

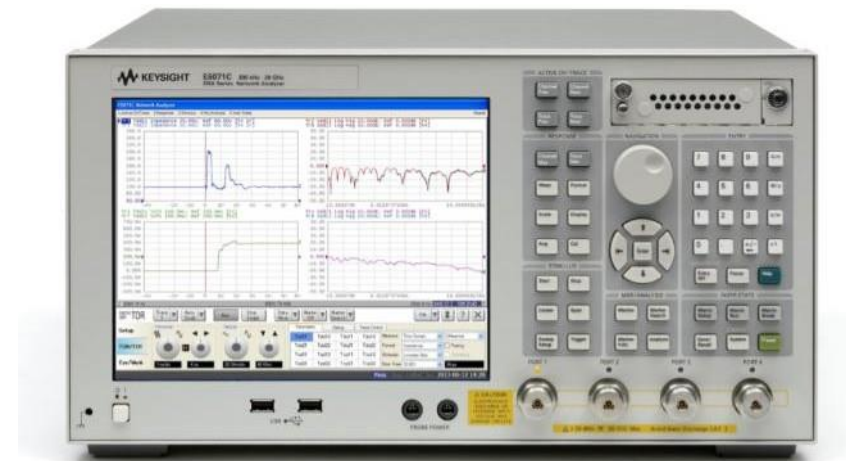

# Reference Documents

## Specifications

### IEEE Std 802.3™-2008

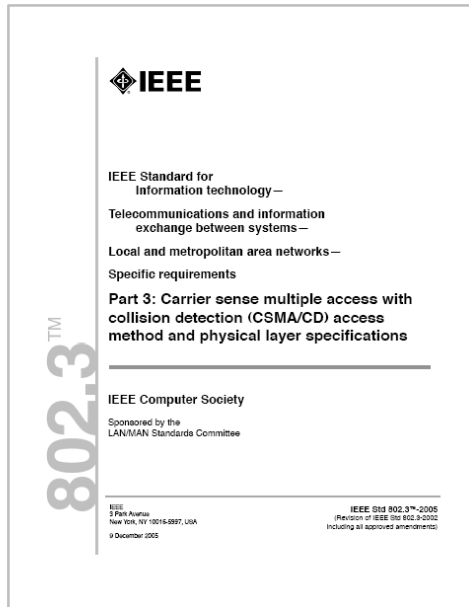

### ANSI X3.263-1995 *Fiber Distributed Interface -Token Ring Twisted Pair Physical Layer Medium Dependent*

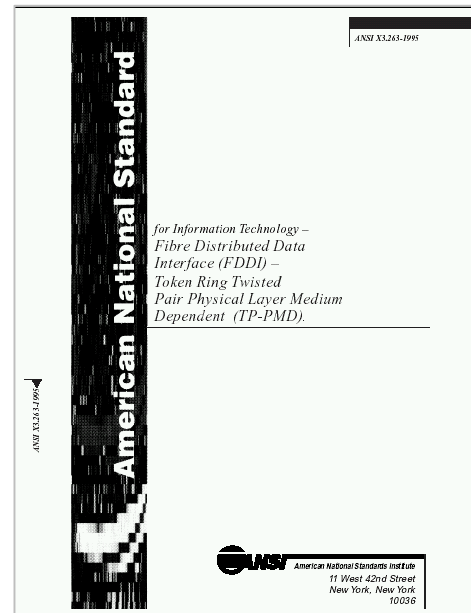

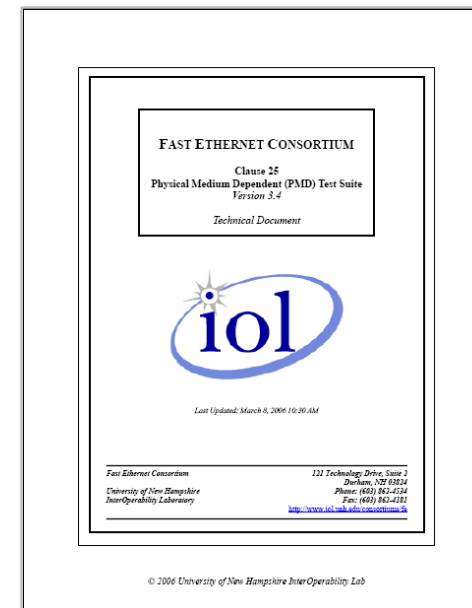

## Test Procedure

### Test Suite for Ethernet University of New Hampshire InterOperability Laboratory (UNH-IOL)



# Ethernet Logo Certification Program

Standard	Standard Body
	USB-IF
	PCI-SIG
	SATA-IO
Ethernet	N/A

**Logo certification program is not available** for Ethernet (100BASE-TX / 1000BASE-T).

- PHY tests performed in accordance to test procedure issued by University of New Hampshire InterOperability Laboratory (UNH-IOL).
- Self-compliance

# Ethernet Data Rate and Distance

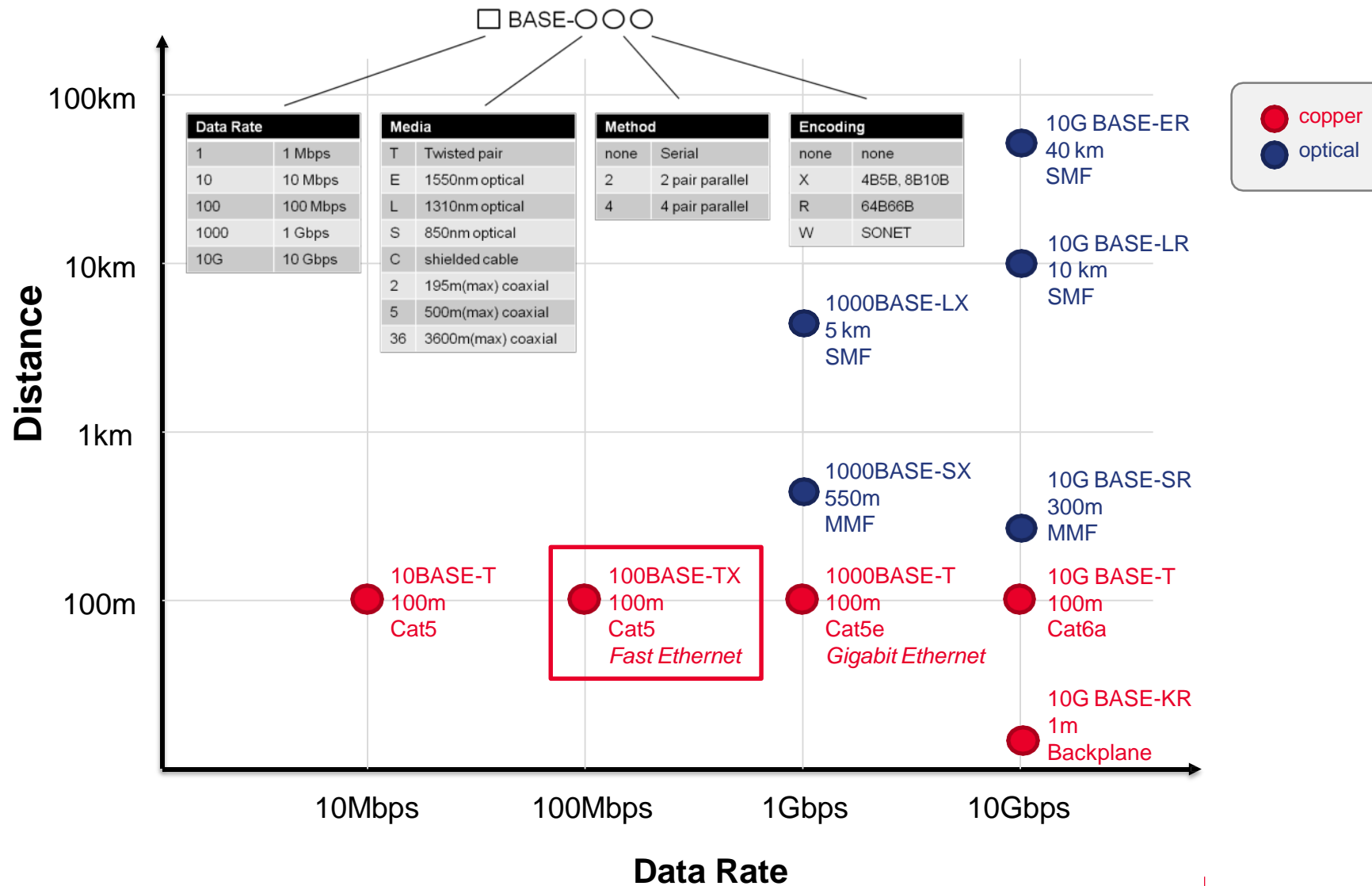

# 100BASE-TX Ethernet Overview

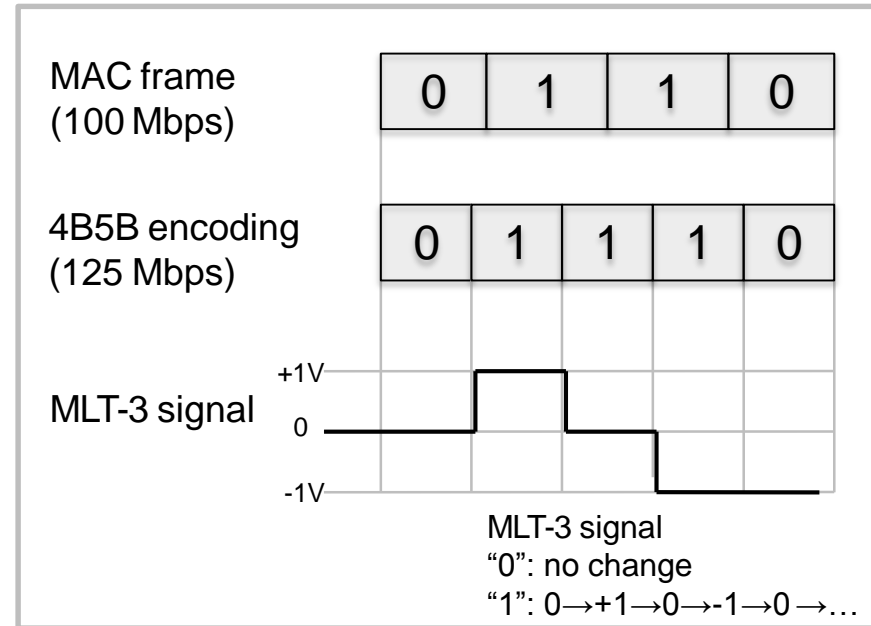
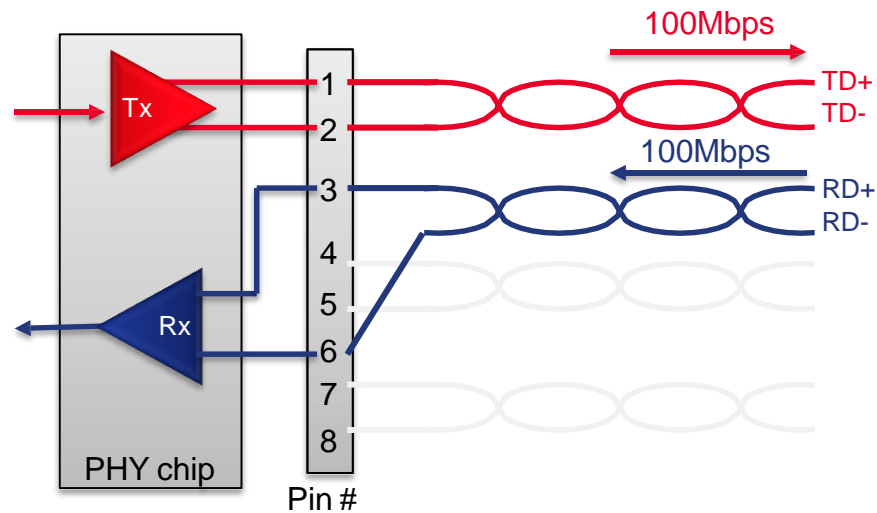

- Data rate: 100 Mbps
- Tx and Rx are independent and use 1 twisted pair each. The remaining 2 pairs are not used.
- **4B5B** MAC frame encoding... convert 4 bit pattern into 5 bit pattern to limit length of consecutive 1s, or 0s to within 4 bits (x1.25)
- **MLT-3** (Multi Level Transmission - 3) modulation used to reduce the signal frequency... No change for a "0", change level sequentially for a "1"
- Highest frequency component is 31.25MHz. **Cat 5** (max 100MHz) cable or better is required.

# 100BASE-TX Ethernet Cable Test

## Measurement Parameters

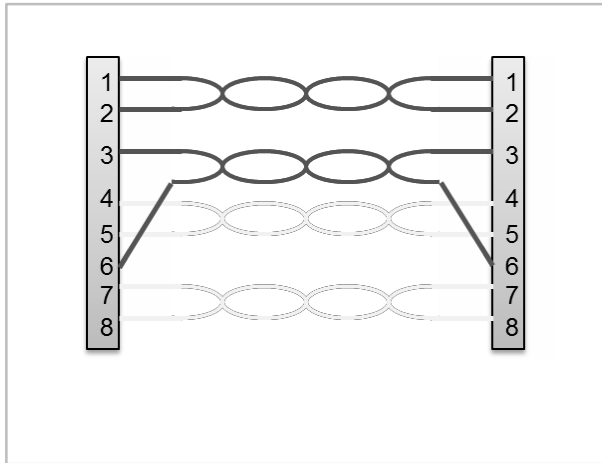

Specification	Test Items
IEEE Std 802.3™-2008	[25.4.7.2.1] Insertion loss
	[25.4.7.2.2] Differential characteristic impedance
	[25.4.7.2.3] Return loss
	[25.4.7.2.4] Differential near-end crosstalk (NEXT)

# 100BASE-TX Ethernet Cable Test Solution

Requirements for both time and frequency domain measurements

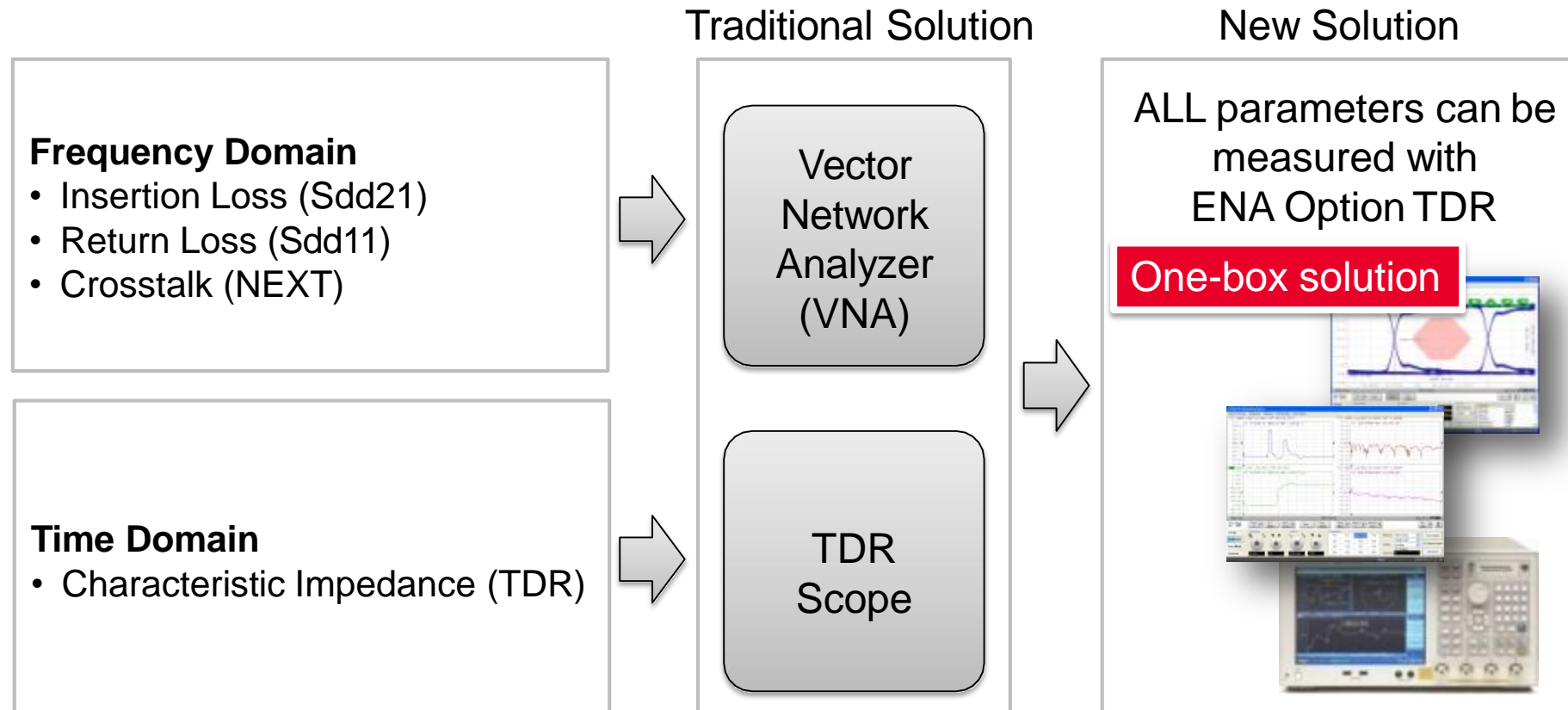

# 100BASE-TX Ethernet Cable Test Solution

## Typical Configuration



- ENA Mainframe
  - E5071C-440/445: 4-port, 9 kHz/100 kHz to 4.5 GHz
  - E5071C-460/465: 4-port, 9 kHz/100 kHz to 6.5 GHz
  - E5071C-480/485: 4-port, 9 kHz/100 kHz to 8.5 GHz
  - E5071C-4D5: 4-port, 300 kHz to 14 GHz
  - E5071C-4K5: 4-port, 300 kHz to 20 GHz
- Enhanced Time Domain Analysis Option (E5071C-TDR)
- ECal Module (N4431B/N4433A)

(\* The list above includes the major equipment required. Please contact our sales representative for configuration details.

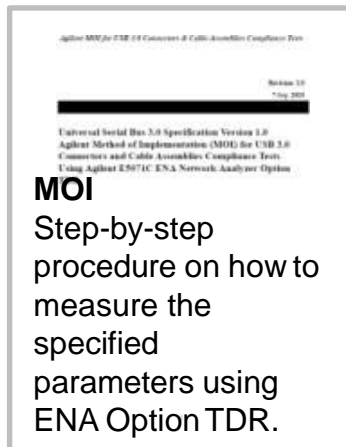

• Method of Implementation (MOI) document and instrument setup files available for free download on Keysight.com

### Test Fixtures

Keysight P/N: N5395C (2 ea)  
Test Fixture for Ethernet Application.

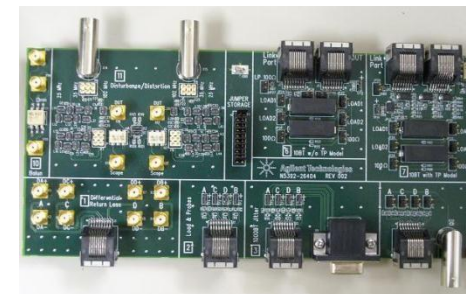

# 100BASE-TX Ethernet Cable Test

## Measurement Parameters

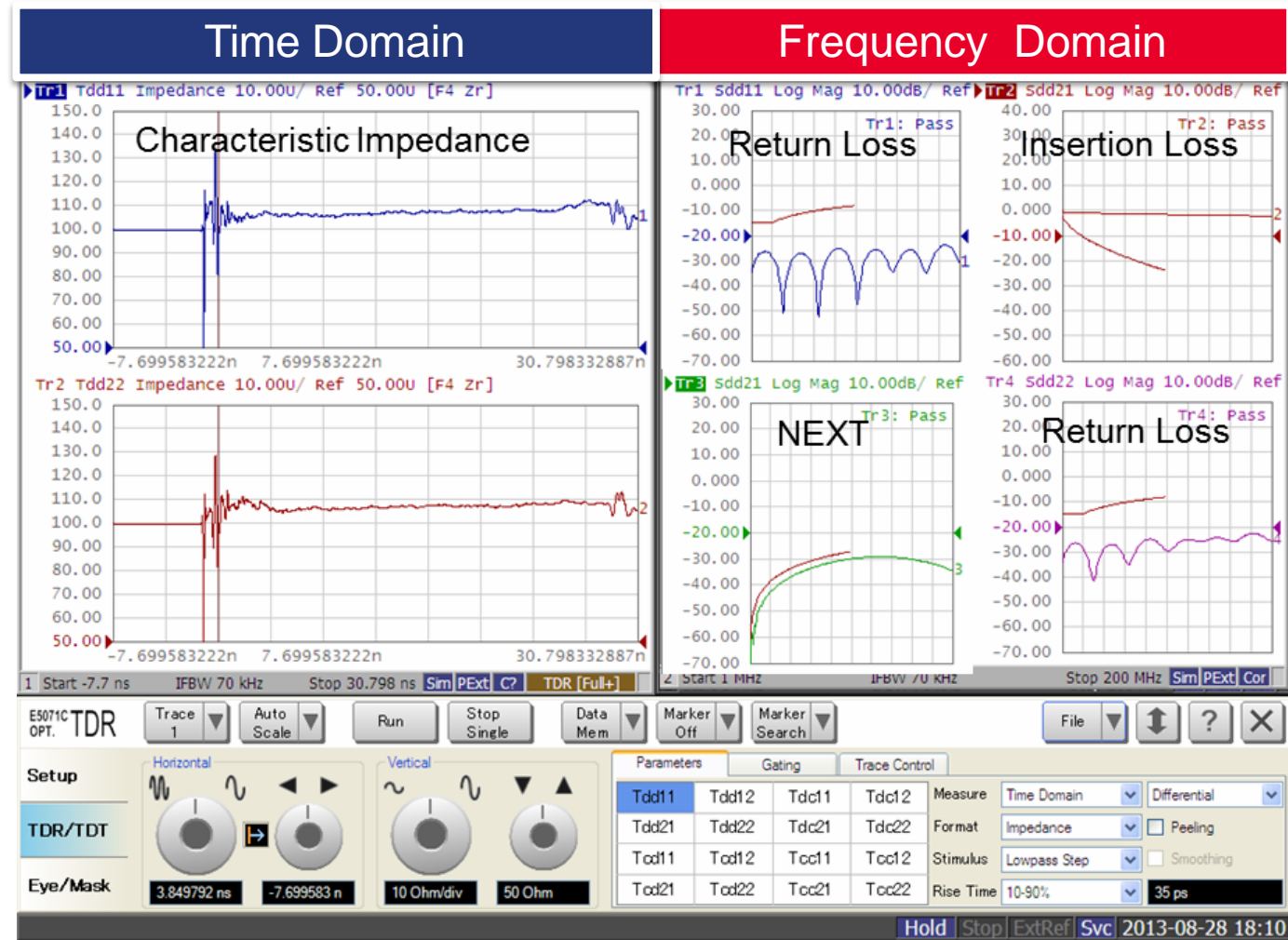

Back up slides

# Real-Time and Sampling Oscilloscope Applications

Total Data Rate	Lane Data Rate	Lanes	IEEE, SFF-8431, CPRI, OBSAI, XAUI, Serial RapidIO, BroadR-Reach	DCA Sampling Scope Model, Option	Real-Time Scope Model, Option
100Mb/s	100Mb/s	1	BroadR-Reach Automotive Ethernet	Call Keysight	N6467A-1FP
10Mb/s 100Mb/s	10/125Mb/s	1/1	10/100 Ethernet Decoder	Call Keysight	N8825A/B-1FP
10Mb/s 100Mb/s 1Gb/s	10/125/125Mb/s	1/1/4	10/100/1G Ethernet	Call Keysight	N5392B-1FP
10Mb/s 100Mb/s 1Gb/s	10/125/125Mb/s	1/1/4	Energy Efficient Ethernet	Call Keysight	N5392B-1FP
2.5Gb/s	200Mb/s	4	MGBASE-T 2.5G	Call Keysight	U7236A/B-4FP
5Gb/s	400Mb/s	4	MGBASE-T 5G	Call Keysight	U7236A/B-3FP
2.5Gb/s	200Mb/s	4	NBASE-T 2.5G	Call Keysight	U7236A/B-6FP
5Gb/s	400Mb/s	4	NBASE-T 5G	Call Keysight	U7236A/B-5FP
10Gb/s	833Mb/s	4	10GBASE-T	Call Keysight	U7236A/B-1FP
10Gb/s	3.072Gb/s	4	CPRI	Call Keysight	N5431A-1FP
10Gb/s	3.072Gb/s	4	OBSAI RP3	Call Keysight	N5431A-1FP
10Gb/s	3.125Gb/s	4	XAUI	Call Keysight	N5431A-1FP
10Gb/s	3.125Gb/s	4	Serial RapidIO	Call Keysight	N5431A-1FP
10Gb/s	3.1875Gb/s	4	10-Gigabit Fibre Channel XAUI	Call Keysight	N5431A-1FP
10Gb/s	3.125Gb/s	4	10GBASE-CX4	Call Keysight	N5431A-1FP
10Gb/s	10.3125Gb/s	1	10GBASE-KR	N1081A-1FP	N8814B-1FP
10Gb/s	10.3125Gb/s	1	10GBASE-KR 64B/66B Decoder	Call Keysight	N8815A-1FP
10Gb/s	10.3125Gb/s	1	SFP+	N1014A-1FP	N6468A-1FP

Green text indicates new product

Blue text indicates product under development

# Real-Time and Sampling Oscilloscope Applications

Total Data Rate	Lane Data Rate	Lanes	IEEE. SFF-8431, CPRI, OBSAI,XAUI, Serial RapidIO, BroadR-Reach	DCA Sampling Scope Model, Option	Real-Time Scope Model, Option
40Gb/s	10.3125Gb/s	4	40GBASE-KR4	N1081A-1FP	N8814A-1FP
40Gb/s	10.3125Gb/s	4	QSFP+	N1014A	N6468A-1FP
40Gb/s	10.3125Gb/s	4	XLAUI	N1081A-2FP	Call Keysight
40Gb/s	10.3125Gb/s	4	CAUI	N1081A-2FP	Call Keysight
40Gb/s	10.3125Gb/s	4	40GBASE-CR4	N1081A-3FP	N8828A-1FP
100Gb/s	10.3125Gb/s	10	100GBASE-CR10	N1081A-3FP	N8828A-1FP
100Gb/s	25.78Gb/s	4	100GBASE-KR4	N1081A-4FP	N8829A-1FP
100Gb/s	25.78Gb/s	4	100GBASE-CR4	N1081A-4FP	N8830A-1FP
100Gb/s	25.78Gb/s	4	CAUI-4	Call Keysight	N6471A-1FP

Green text indicates new product

Blue text indicates product under development