



AHEAD OF WHAT'S POSSIBLE™

High Performance Inertial Sensors Propel the Internet of Moving Things

BOB SCANNELL

Inertial MEMs Product Manager

07/19/2017

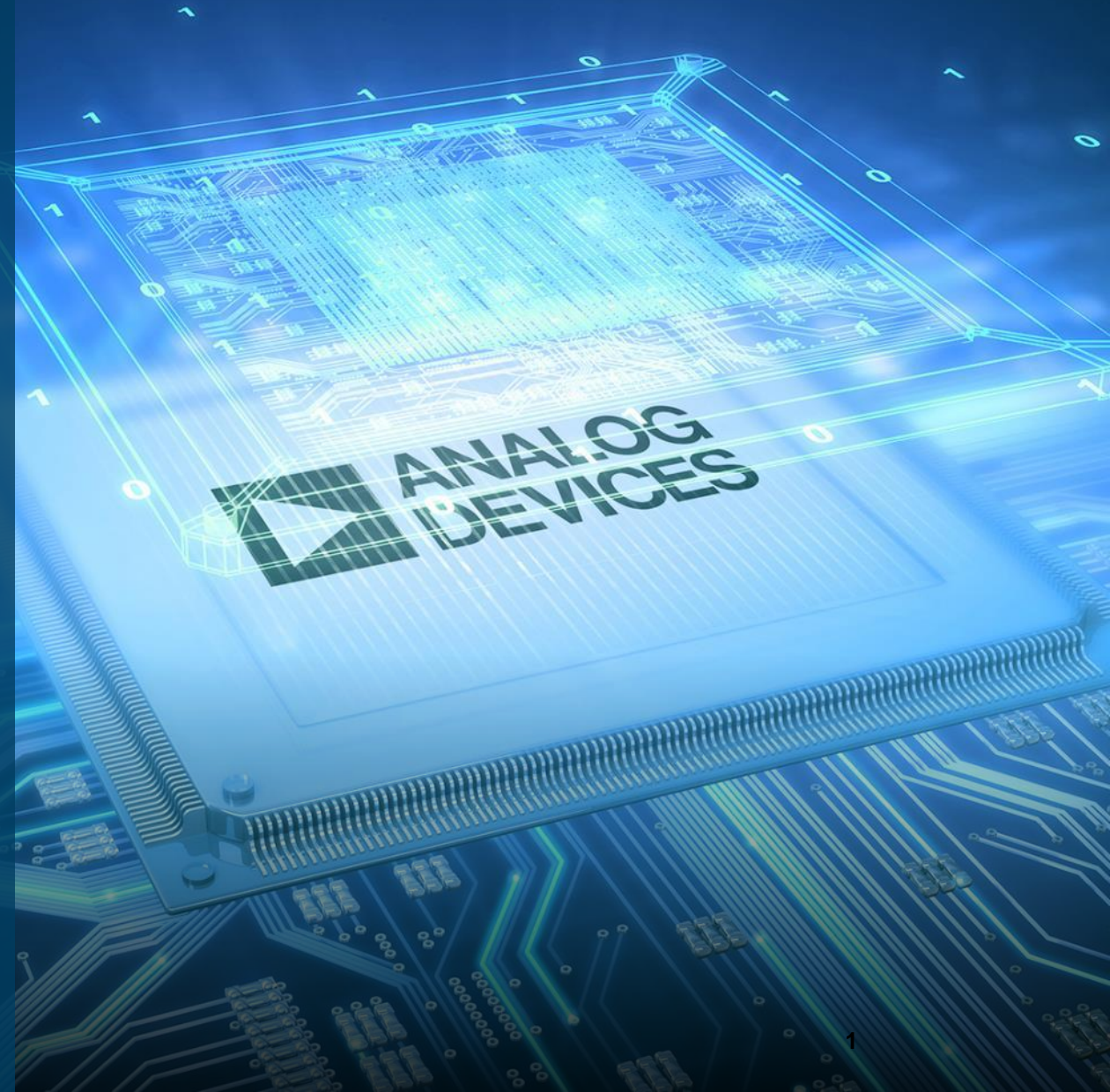

Presentation Outline

- ▶ Where and why Motion Matters to the IoT
- ▶ Internet of Moving Things (IoMT) Relevant Applications
- ▶ Achieving Precision and Accuracy
- ▶ Sensor Technology and Integration, for Performance
- ▶ System Application Level Considerations
- ▶ Solutions

Evolution of Autonomous Machines...

- ▶ Sensors are enabling a shift in Machinery from traditional *Mechanical, Fixed-function, Stationary devices* ... to increasingly *Intelligent, Autonomous, and Mobile devices*.
- ▶ Machine *Measurement* is augmented to be Machine *Control*, and evolves to Machine *Automation and Learning*
- ▶ From Sensors
 - ... to *Multi-Sensors*
 - ... to *Fused Sensors*
 - ... to *Smart Sensors*
 - ... to *Connected Sensors*
 - ... to *Intelligent Sensors*
 - ... to

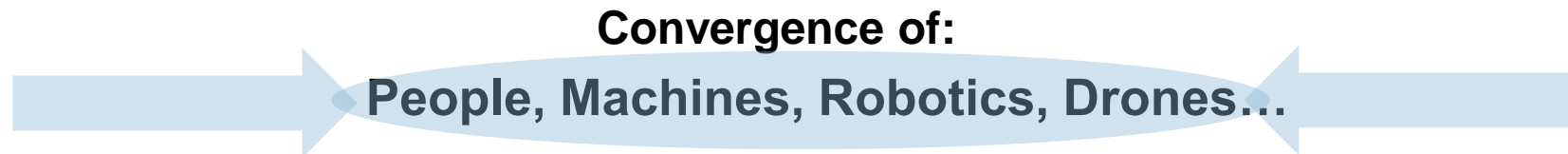

Sensor-rich IoT Nodes are Increasingly Autonomous and Mobile

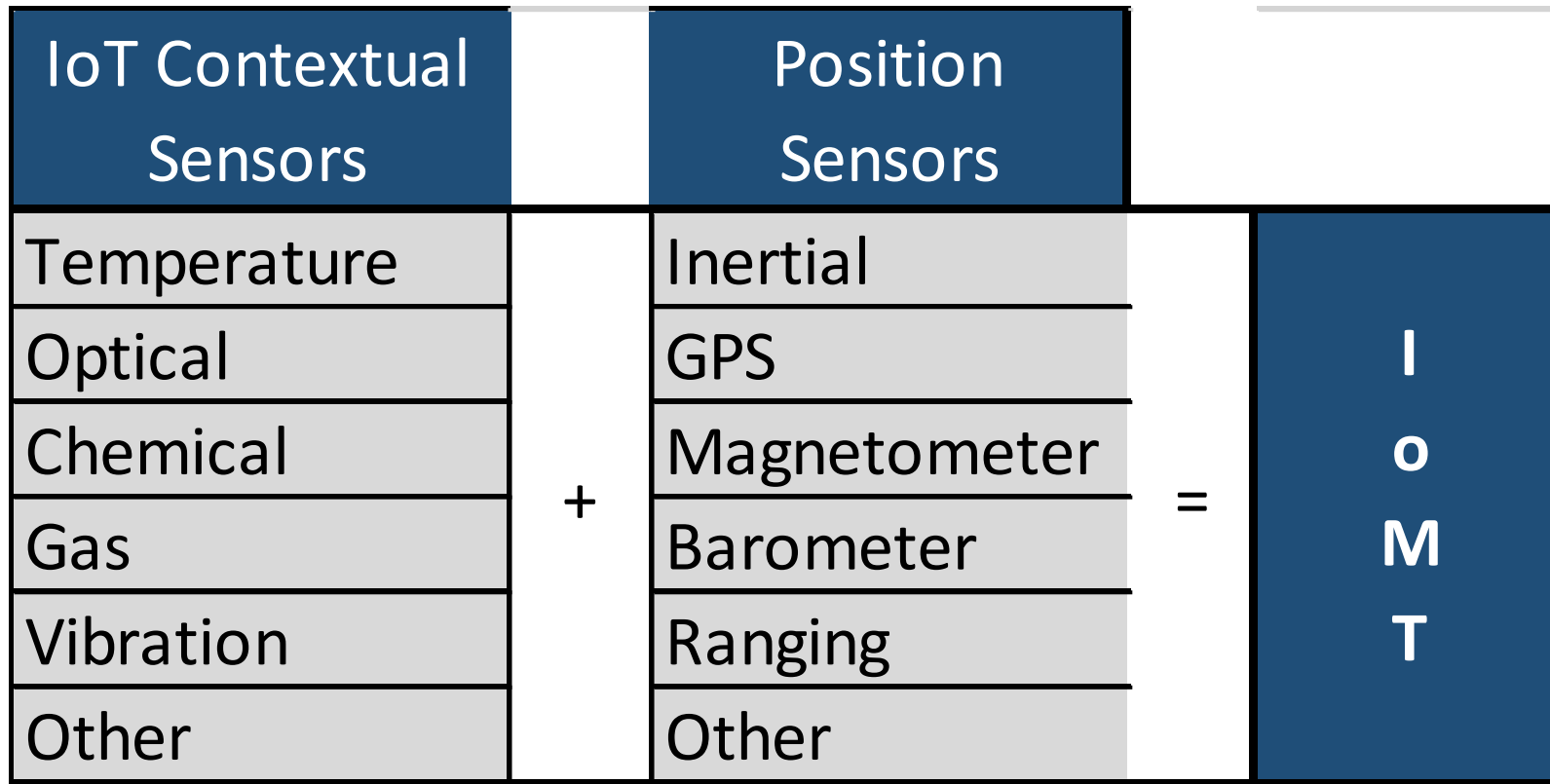

Motion/Position, or lack-of-motion (ie: Stabilized Pointing), is a valuable datapoint for the operational efficiency of many autonomous machines

Targeting High-Value Applications

System Drivers	Example Applications	Critical Needs
Resource Efficiency	Precision Farming; Inventory/Asset Control; Surveillance; Predictive Maintenance; ...	Multi-parameter sensing; Geo-Location; Data-basing / referencing; ...
Critical Accuracy	Factory Robotics; Surgical Instruments; Construction; Vehicle Guidance; ...	Precision; Stability; Repeatability; All-Condition Operation; ...
Improved Safety	Unmanned Vehicles; Condition Monitoring; Autonomous Machines; First Responders; ...	Reliability; Environmental Immunity; Ruggedness; Predictive Analysis; Fail-safe modes; ...

Quality and Accuracy of Sensor Data is the core enabler to achieving Challenging System Goals

Examples of Motion Relevance, by Application

Industrial Equipment	Motion Relevance
Smart Tractor	Geo-Location; Antenna Stabilization
UAV/Drone	Geo-Location; Swarming; Payload Pointing
First Responder	Geo-Location; Mapping; Activity Monitor
High Value Assets	Geo-Location; Inventory Control
Train, Other Transport	Geo-Location; Safety
Augmented Reality	Geo-Location; Pointing
Smart Vehicles	Geo-Location; Sensor-Positioning; Dynamics
Robotics, Machinery	Geo-Location; Controls, Stabilization
Antennas, Cameras	Pointing Angle; Installation/Calibrations; Stabilization

Determining Position in Difficult Application Scenarios

- ▶ **Typical Problem:** correction for outages or inaccuracies in primary sensing/feedback loops for guidance and controls
- ▶ **Needed Solutions:** stable, low noise, vibration immune, inertial sensing cluster. Reduce jitter, and provide primary guidance during outages, or disruptions of other sensors

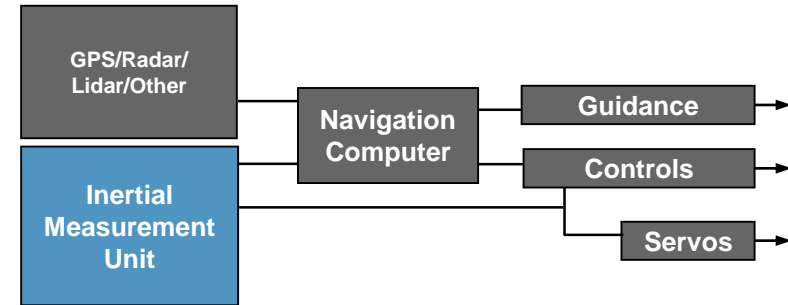

Applications:

- Precision Agriculture/Construction
 - Auto-Steer
 - Smart Implements
- Autonomous Machines
 - Drones
 - Robotics
- Internet of Moving Things

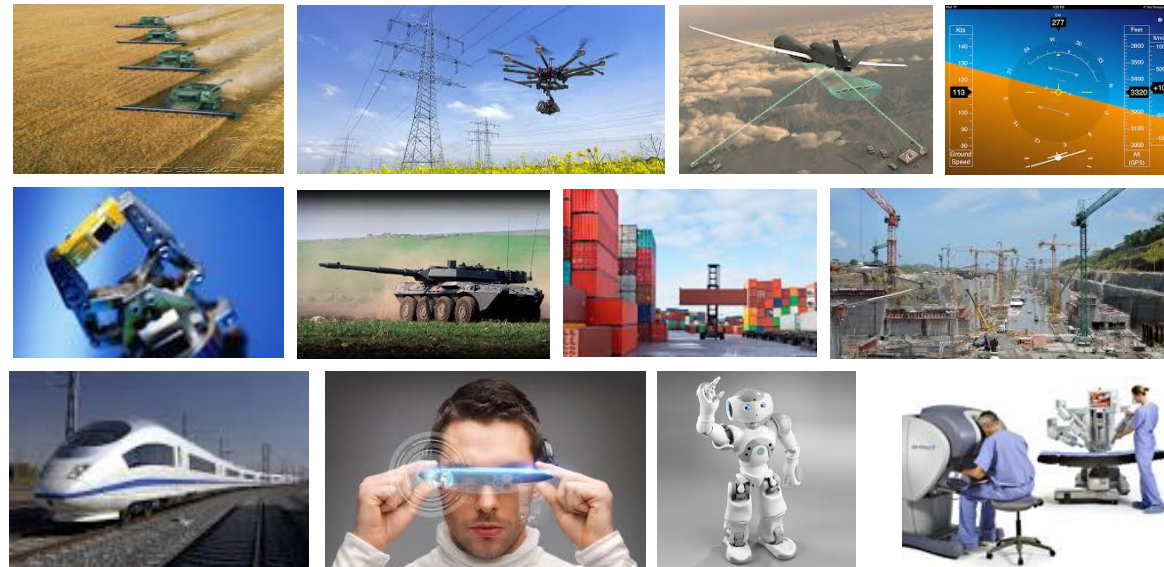

Elements of a Valuable IoMT System

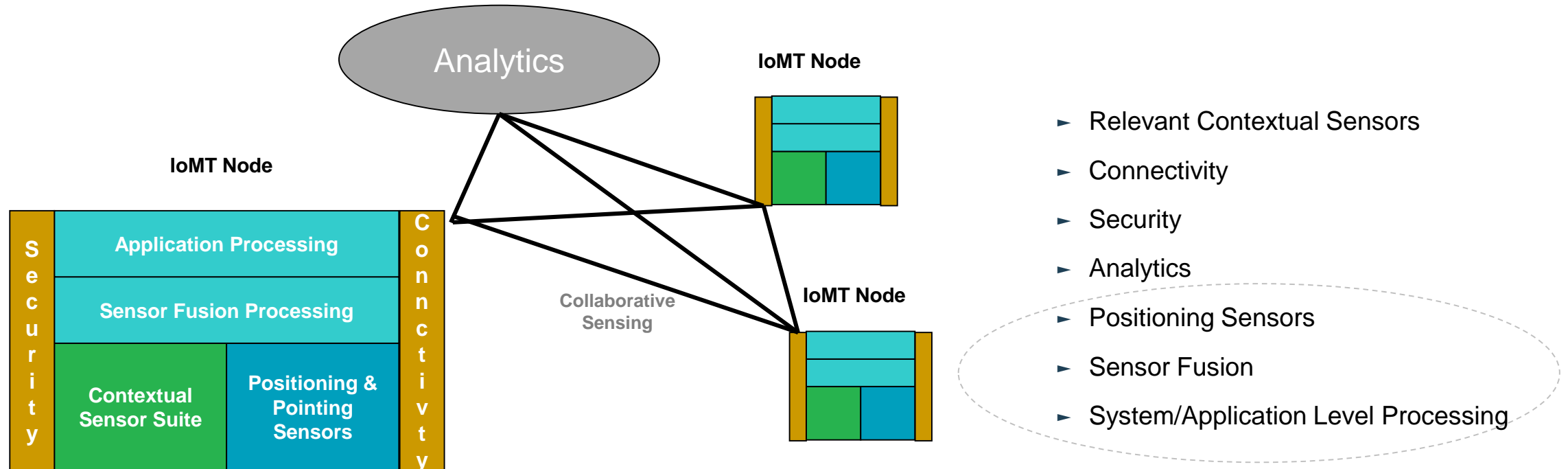

Precision Sensors at the core of Intelligent Integration and actionable information at the Edge Node

Industrial Applications Involve Complex Motion Sensing

► Simple motion sensing:

- Up/down/left/right, good enough
- Non-inertial sensors much more highly weighted (ie: GPS)
- Highly constrained (restricted) conditions
- Errors/bugs easily forgiven

► Industrial reality:

- Pointing accuracy better than 1°
- Inertial sensors more heavily relied on
- Complex/unpredictable conditions
- Sensor accuracy is mission critical

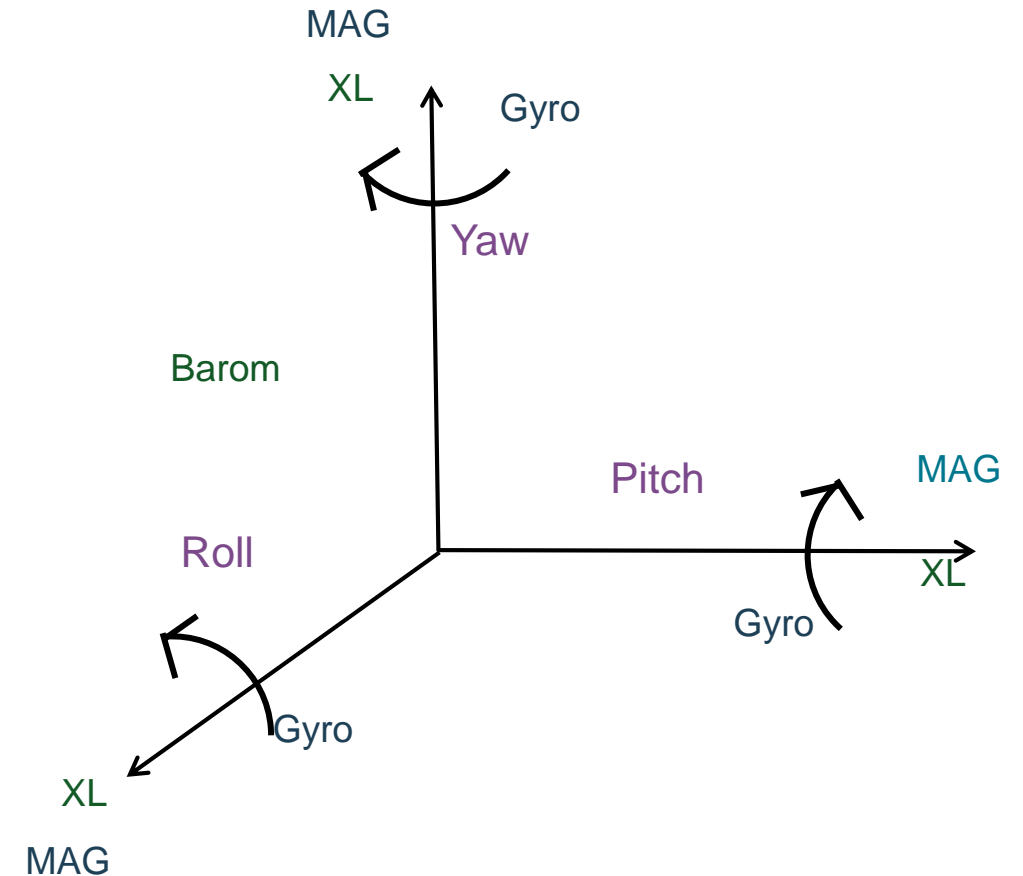

Sensor Choice Critical to Final Accuracy, and Value, of the System

Inertial Sensor Quality	Characteristics	Role in Sensor Fusion	Accuracy after Sensor Fusion	Suitable for:
High Precision	Ultra Low Noise, Stable operation under all conditions	Primary Sensor, heavily relied on, capable of supporting rugged/ unpredictable conditions	$\sim 0.1^\circ$	Complex Motion, Long Life, Mission Critical
Low Precision	Low to Moderate Noise, Poor Stability, Unspecified drift under vibration-temp-shock	back-up sensor with low weighting, restricted or conditional reliability	$3-5^\circ$	Simple Motion, Short Life, Error Tolerant use cases

Summary of Key Challenges for Consideration in Early Design Choice Phase

Key Challenges
Centimeter Level Accuracy in midst of GSP Blockage
Maintain Accuracy even under Vibration, Temperature extremes, Wind, etc
Reliable, Safe Operation, all-Conditions

Extracting Valuable Precision from Sensors, through Design and Integration

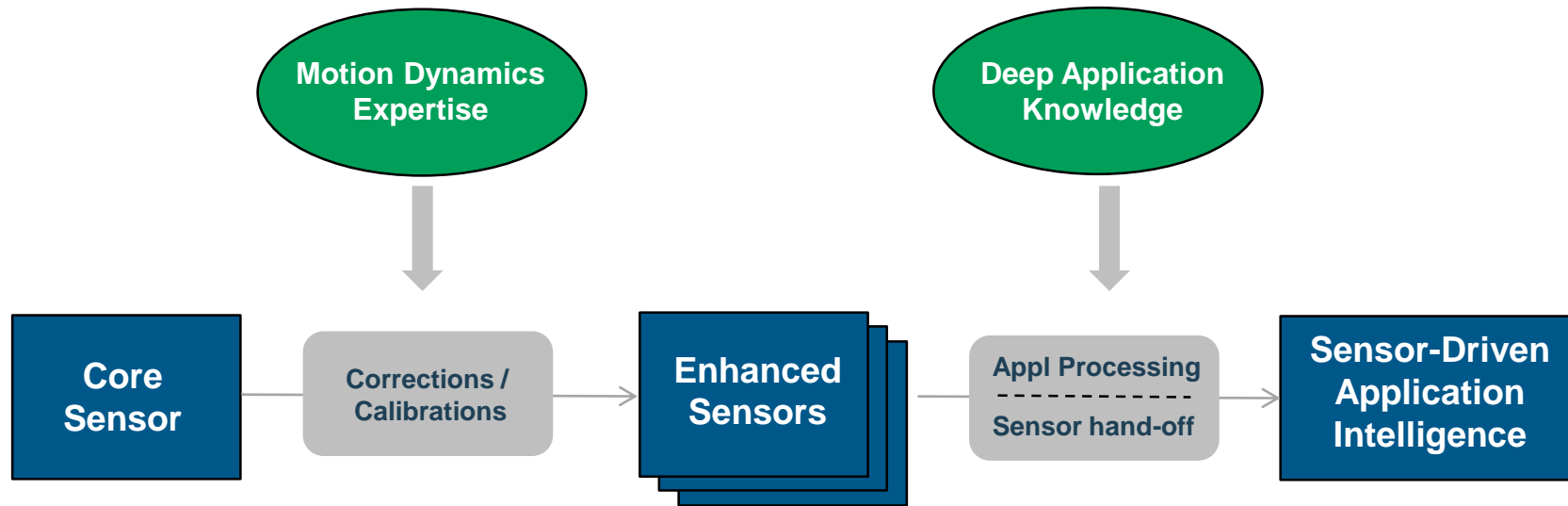

Accelerometer Principle of Operation

- ▶ Silicon emulates the traditional spring/mass system, with fingers to make a variable differential capacitor
 - Detect change in displacement by measuring change in differential capacitance

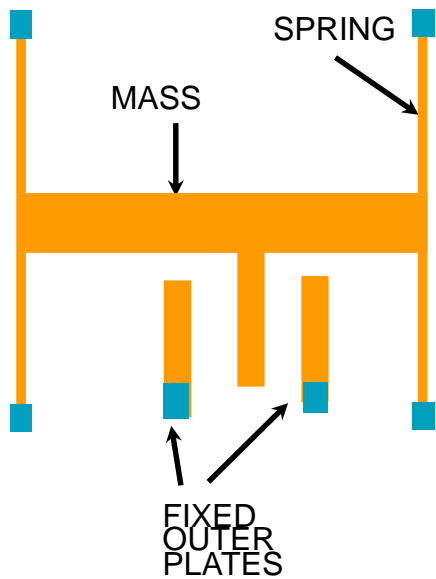

Sensor at Rest

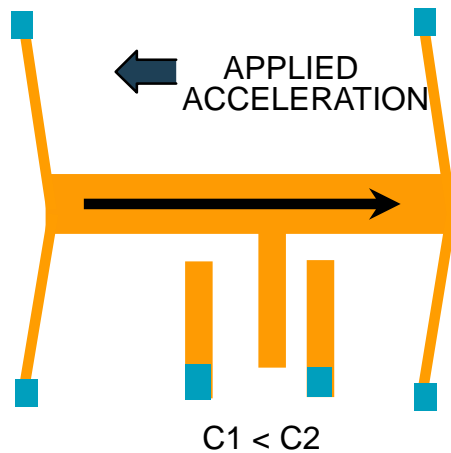

Responding to an Applied Acceleration

■ ANCHOR TO SUBSTRATE

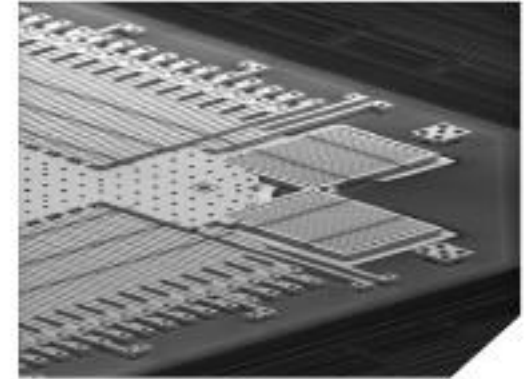
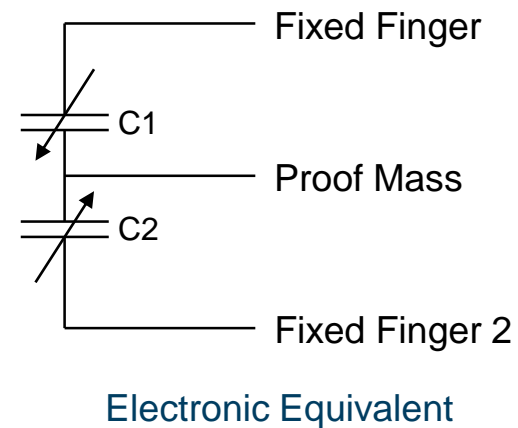

MEMs Accelerometers are sensitive to both Dynamic and Static Acceleration

Gyroscope Principal of Operation

- ▶ Measure Angular Rate through Detection of the Coriolis Force
- ▶ What is the Coriolis force?
 - When an object is moving in a periodic fashion (either oscillating or rotating), rotating the object in an orthogonal plane to its periodic motion causes a translational force in the other orthogonal direction.

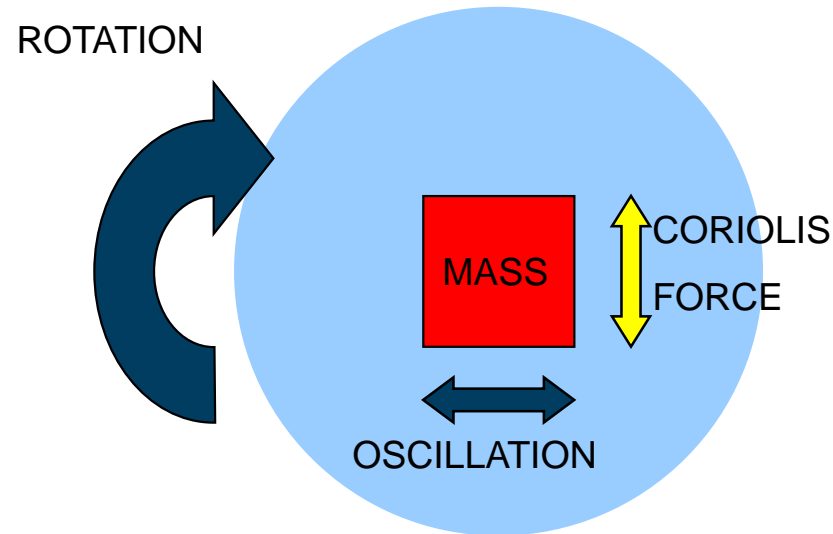

- ▶ Gyroscopes can be Sensitive to g -effect
- ▶ Accelerometers cannot by themselves distinguish one type of ' g ' from another

IMU Serves Key Sensor Fusion Role within Industrial Systems

Determining System-State Within Complex Applications

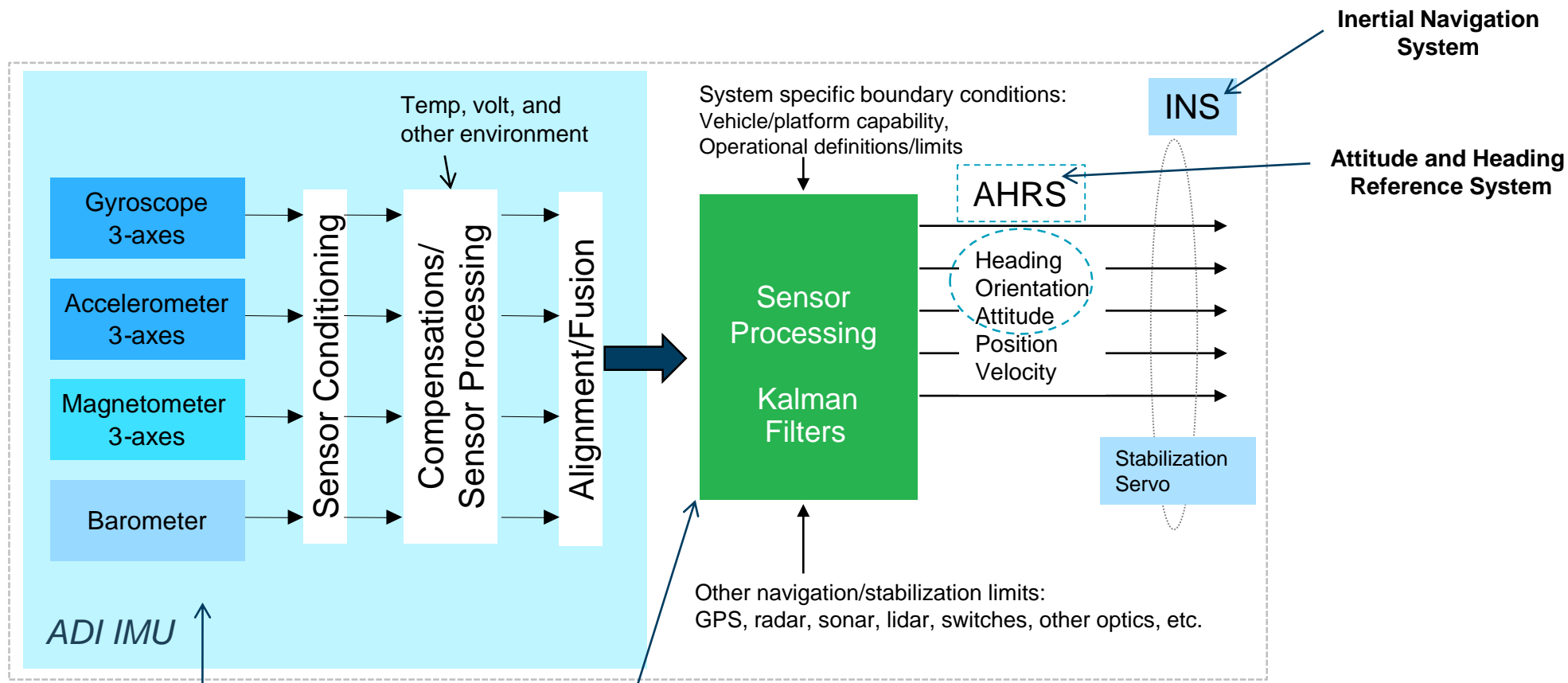

Inertial Measurement Unit

- ▶ Typically 4 to 10 degrees of freedom
- ▶ Stable, precision sensor outputs
- ▶ Environmental, cross-axis, cross-sensor corrections

Kalman Filter

- Kalman filter merges multiple imperfect and complimentary sensors, and determines actual motion
- ▶ System dynamics model, boundary conditions
 - ▶ Control inputs; weighting
 - ▶ Sensor inputs

Not all Inertial Sensors are Alike....

- ▶ Most Sensors today offer relatively low noise
- ▶ The choice of highly stable sensors is much more restrictive
- ▶ Application–level precision is highly dependent on several often ‘ignored’ specifications: g-effect, alignment, other drift factors
- ▶ Industrial Specified Sensors provide details of all specifications that are critical to the system error budget
- ▶ The best industrial sensors ensure that all of the potential error sources are well balanced.

Parameter	Typical Industrial Spec	units	Delta Improvement over typical consumer device
GYROSCOPES			
Dynamic Range	up to 2000	deg/sec	~
Noise Denisty	0.004	°/sec/√Hz rms	2X
Angular Random Walk	0.2	°/√Hr	2X
in-run stability	6	°/hr	3X
Bias repeatability	0.2	°/sec	100X
–3 dB Bandwidth	465	Hz	2X
ACCELEROMETERS			
Dynamic Range	up to 40	g	3X
Noise Denisty	25	ug/√Hz	10X
Velocity Random Walk	0.03	m/s/√Hr	10X
in-run stability	10	micro-g	10X
Bias Repeatability	25	mg	100X
–3 dB Bandwidth	500	Hz	2X
		°/sec/√Hz rms	
Axial Alignment	0.05	deg	20X
Linear Acceleration Effect	0.01	°/sec/g	10X
Vibration Rectification	0.004	°/sec/g ²	10X
Sensitivity Tempco	25	ppm/°C	10X
Bias Tempco	0.007	°/s/°C	10X

Sensor Selection Drives Application Accuracy

Stabilization Accuracy (minimize angular jitter):
 Select Sensors capable of $<1^\circ$ Pointing error,
 under complex motion-dynamics



Navigational Accuracy:
 Higher Quality Inertial Sensor Outputs can:

- Reduce Complexity of Sensor Fusion/Processing
- Improve Confidence in Outputs
- Increase Precision of Location (>50X)



Jitter = RSS of Noise+Vibration+CrossAxisSensitivity

Example IMUs	Industrial		Consumer	
	Spec	Impact	Spec	Impact
PERFORMANCE				
Noise density ($^\circ/\text{sec}/\sqrt{\text{Hz}}$)	0.004	0.036	0.0100	0.089
Linear-g ($^\circ/\text{sec}/g$)	0.01	0.020	0.100	0.200
Cross-axis (%)	0.09%	0.090	2.00%	2.000
PROJECTED ERROR ($^\circ/\text{sec}$)		0.099		2.012 ← ~best-case

Assumptions: 50Hz BW, 2 g-rms vibration, 100°/s off-axis rotation

MEMs Performance	error, as % of distance traveled
Mil-Grade	~0.1%
Industrial	<0.5%
Consumer	>>25%

Sensor Fusion - Merits and Cautions...

Sensor Fusion can:

- 1) Provide Corrections for Detectable Drift, based on reliable alternate sources
- 2) Perform hand-off, mapped to Application-State

Sensor Fusion cannot:

- Fix poor quality sensors

Industrial Dead Reckoning

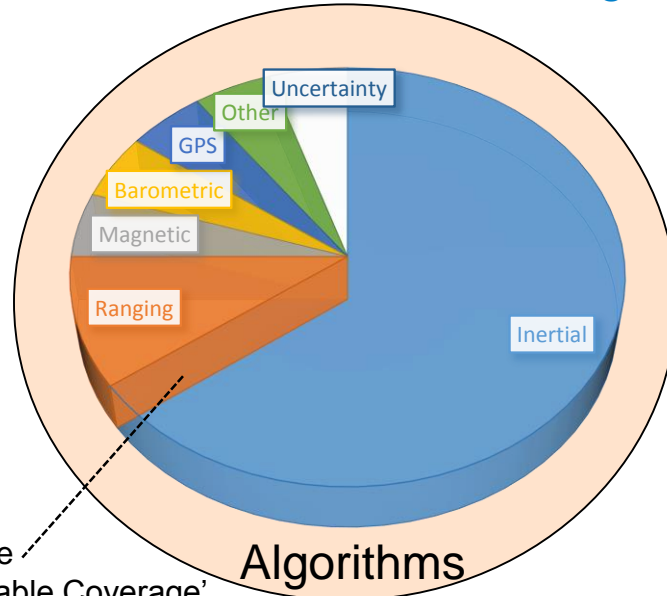

Consumer Dead Reckoning

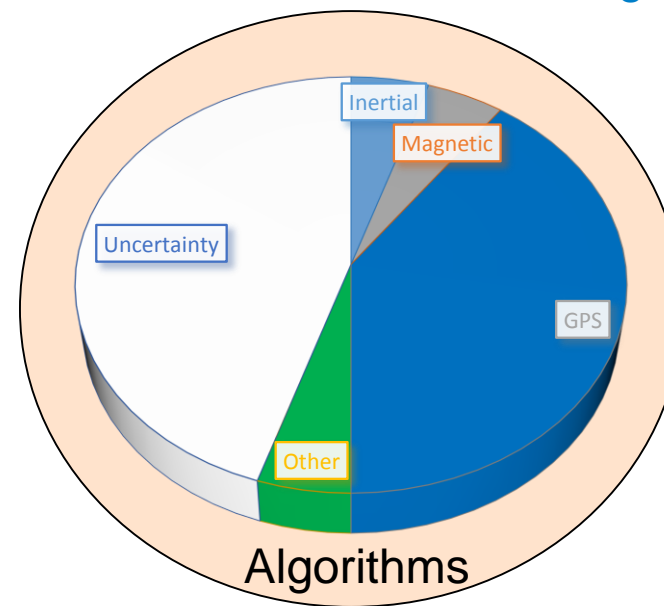

Portions indicate 'Amount of Reliable Coverage' relative to Application-state

- **Algorithms/Filtering do not Fill the Uncertainty Gap**
- **Confidence/Accuracy of Position is Dictated by the Sensor Quality**

Application Example, and Motion Relevance

Motion Sensing Opportunities within Drones/UAVs

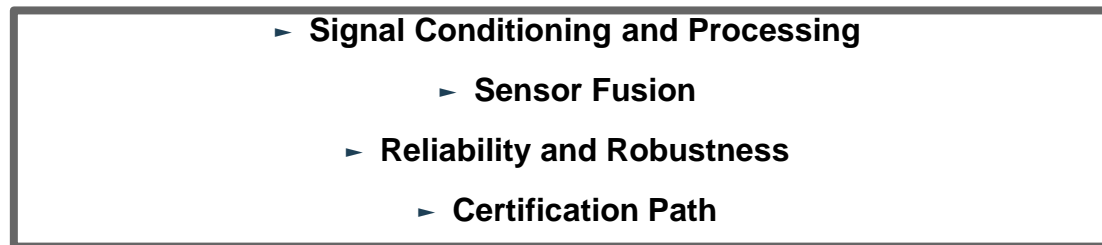
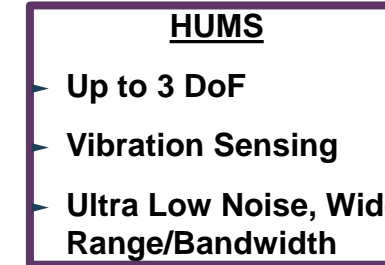
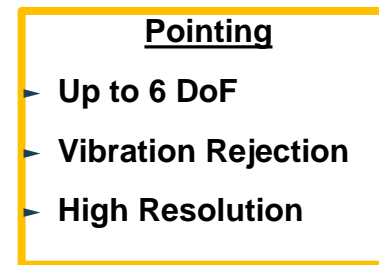
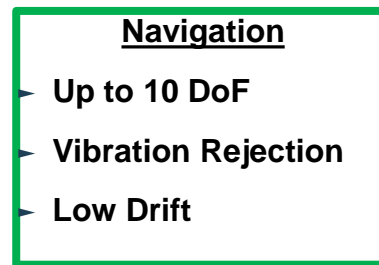
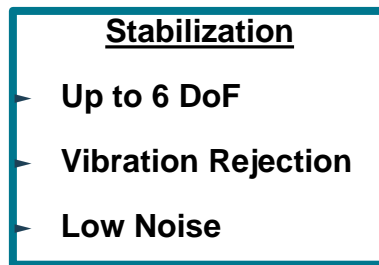
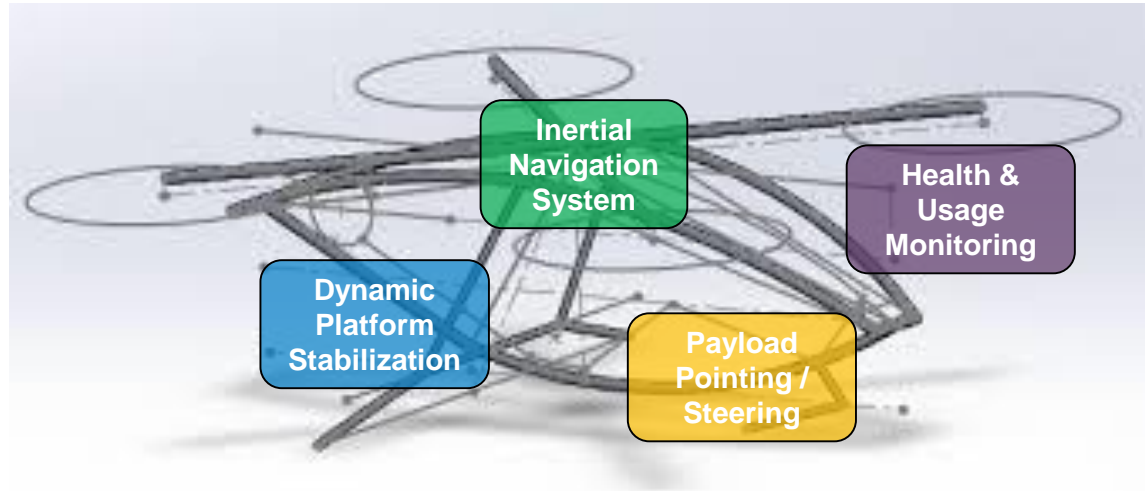

Application Example, and Motion Relevance

Tracking High Value Assets, ie: First Responders

Mission Interval	Primary Sensing	Auxiliary Sensing	Period	Accuracy
Arrival at Scene	GPS	Inertial	- - -	Map Fix
Deployment	Ranging/Other	Inertial	Unknown	Decimeters
Inside Building	Inertial	Signals of Opportunity	~30 minutes	Meters
Rescue	Inertial	Path-Map, Other	Minutes	



Application Example, and Motion Relevance

Smart Agriculture, the Mobile Factory...

Multiple Interconnected Systems

- Equipment Management
- Resource Management
 - Water
 - Seed
 - Fertilizer
 - Pesticide
- Field Monitors (soil moisture...)
- Weather Stations
- Aerial Sensors
- Mapping
- Geo-referenced Data
- 'Prescription' based, or real-time Variable Rate Controls
- Active Safety



- Enabled by Positioning
- Sensor Rich Potential
- High-level of Connectivity

Choosing the right Sensors when Performance, Reliability, and Ruggedness Matter

IoMT promises aggressive growth, not only for consumer level applications, but within **emerging high-value applications.**

Market acceptance and growth within these Emerging Opportunities is also risked by challenges in **performance, safety, reliability, standards, regulations, etc.**

Technology choices exist today which offer reliable performance, **without compromising system level size-weight-power-cost goals**



Consumer Grade MEMs

- Compromised Performance
- Added Cost from Test/Calibration/Yield-loss
- Added Cost of complex packaging, vibration/thermal isolation
- Software 'band-aids'
- Life-cycle performance drifts from Plastic Packaging...
- Component Obsolescence
- Compromised Reliability...operational failure

Industrial Grade MEMs

- ✓ Superior Performance
- ✓ Ruggedized, Application-ready
- ✓ Stability: Performance and Supply/Availability
- ✓ Reliability: up to full Avionics Certifiable

➤ *Lower Overall System
Size/Weight/Power/Cost*

Available Component and Module Inertial Solutions for High Performance Applications

▶ Low Noise, Low Drift, Vibration Rejecting Gyroscopes

- ADXRS290/5, dual axis
- ADXRS646, single axis
- ADXRS62X, 453 lower-perf, cost

▶ Low Noise, Low Drift Accelerometers

- ADXL35X, tri axis
- ADXL203, dual axis
- ADXL34X, 350: lower perf, cost

▶ Six DoF Inertial Measurement Units

- ADIS1649X, 485 Tactical Grade Performance
- ADIS1646X/47X, best size/cost
- ADIS16445 cost/performance

▶ Ten DoF Inertial Measurement Units

- ADIS16448 cost/performance
- ADIS16488 highest performance

▶ Vibration / HUMs / Shock Sensors

- ADXL100X, single axis, ultra low noise
- ADIS16228, tri axis, integrated FFT
- ADXL372, tri axis, Hi-g, ultra low noise/power

▶ AHRS

- ADIS16480, attitude and heading outputs

▶ Tilt Sensors

- ADIS16209, dual-axis precision inclination
- ADIS16210, tri-axis precision inclination

▶ Motion Activation/Monitoring

- ADXL362, tri-axis ultra low power accel/'switch'

ADI IMU Advancements Emphasize Performance Gains, while Addressing Integration and Cost Efficiencies of Emerging Industrial Applications

ADI IMU Production Portfolio

HIGH PERFORMANCE



- ▶ Best Performance for Price
- ▶ Disruptive to Legacy Military Solutions



Portfolio Expansion Upcoming



- ▶ ~5X Performance Improvement
- ▶ Interface Compatible

COMPACT PERFORMANCE



- ▶ Order-of-Magnitude Higher Performance than Consumer IMUs
- ▶ #1 Market Share in Industrial IMU



- ▶ Fraction of Size of Previous Gen
- ▶ Up to 10X Higher Performance
- ▶ Multiple Assembly/Interface Options

IoMT Requires Unique Solutions

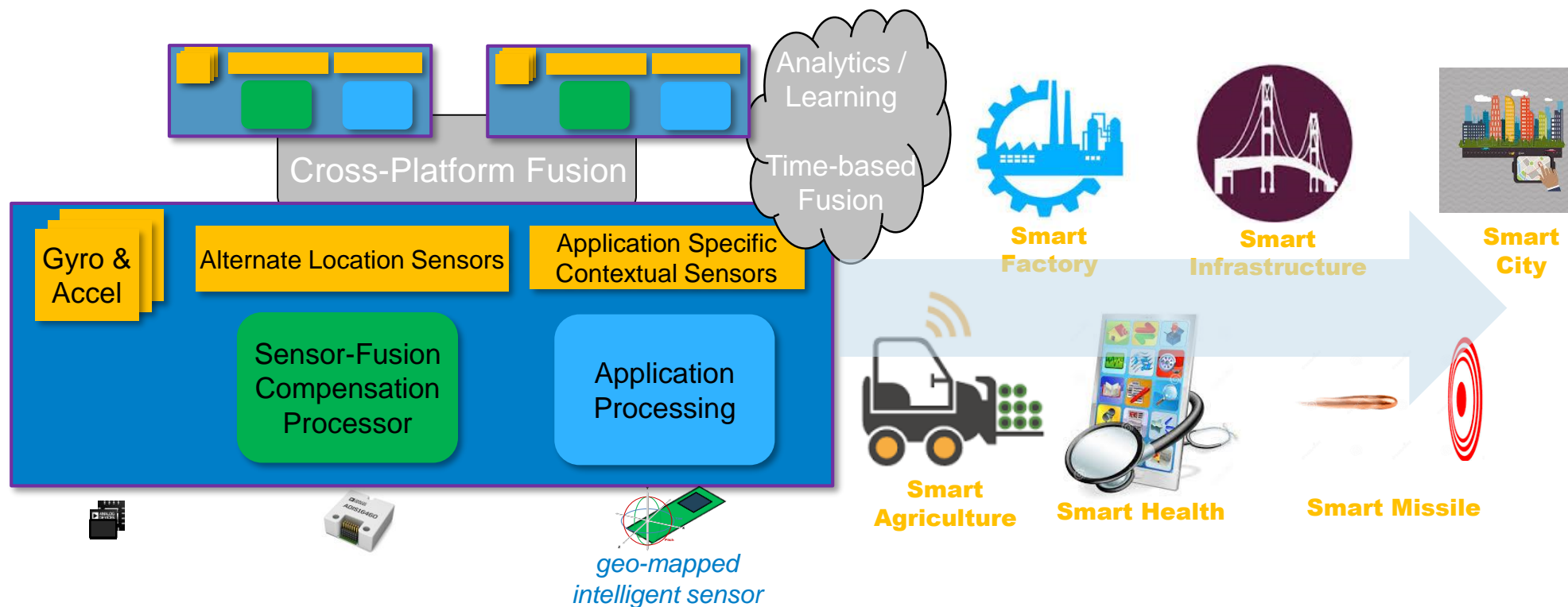

- Location Aware Industrial Smart Sensing propels Growth and Value in Autonomous Machines
- Challenging System Goals enabled by Quality and Accuracy of Sensor Data
- Precision Sensors drive Intelligent Integration and Actionable Information at the Edge Node

Thank You For Watching!

View Additional Webcasts at
www.analog.com/Webcasts

Ask Questions on EngineerZone
ez.analog.com/Webcasts

Search for ADI Parts on Arrow
Arrow.com