

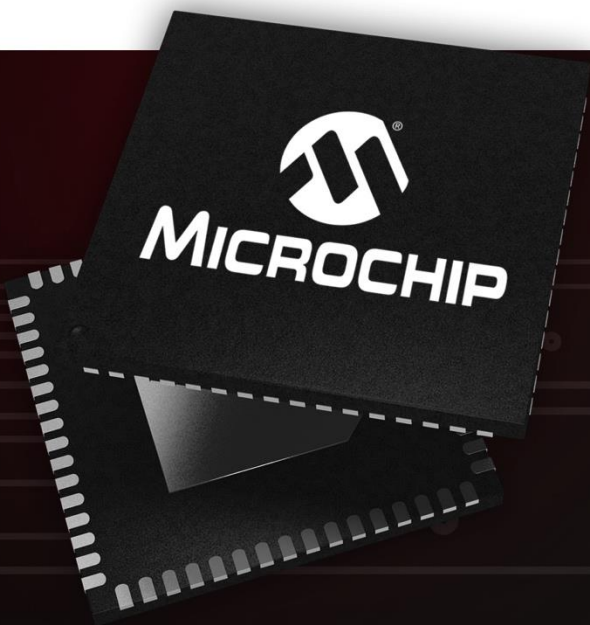

# MICROCHIP



A Leading Provider of Microcontroller, Security, Mixed-Signal, Analog & Flash-IP Solutions



***Advances in Bluetooth® audio technology and applications***  
***Terry Kim, Sr. Embedded Solutions Engineer***  
***September 24, 2019***

# What is Bluetooth®?

- **Wireless Data Exchange Technology operating within the unlicensed ISM 2.4 to 2.48 GHz band**
- **Managed by Bluetooth Special Interest Group (SIG)**
  - Established in 1998
  - Over 16,000 member companies
  - Must be a member to use Bluetooth logo (no cost)
  - Manages Qualified Design ID for components
  - Manages Declaration ID for specific end-product features
- **Typically 1 Master Talking to 1 Slave**
  - Data transfer is usually bi-directional between Master & Slave
- **Connection Process**
  - Discovery
  - Pairing
  - Authentication(optional)



# Bluetooth® Specification

- **Bluetooth 1.0 and 1.0B + BR** Jul 1999
- **Bluetooth 1.1**
- **Bluetooth 1.2** Nov 2003
- **Bluetooth 2.0 + EDR** Nov 2004
- **Bluetooth 2.1 + EDR** Mar 2007
- **Bluetooth 3.0 + HS** Apr 2009
- **Bluetooth 4.0 + LE** Dec 2009
- **Bluetooth 4.1** Dec 2013
- **Bluetooth 4.2** Dec 2014
- **Bluetooth 5** Dec 2016

# Bluetooth® Solutions

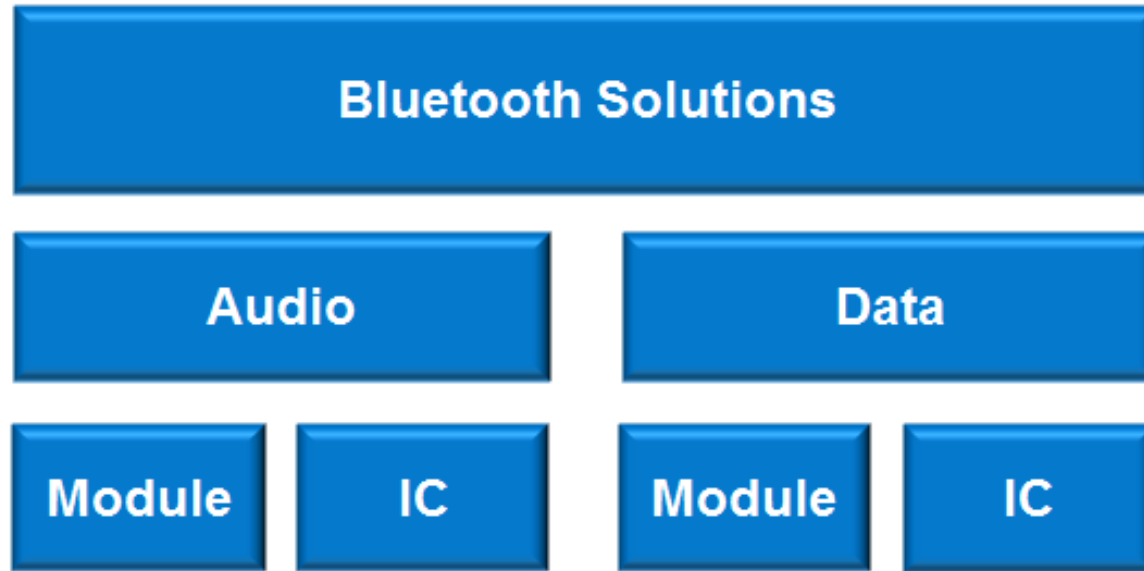

Module	Ease of Use, Shield & No-shield, 3 <sup>rd</sup> Party Option
IC	Form Factor, High Volume

***Broad Product Selection – Single Company for Bluetooth ICs, Modules and SW Stack***

# Bluetooth® Communication



- Media Streaming
- CODEC/Encoder
- Content Protection

- CODEC/Decoder
- Audio Rendering
- DAC, Audio Output

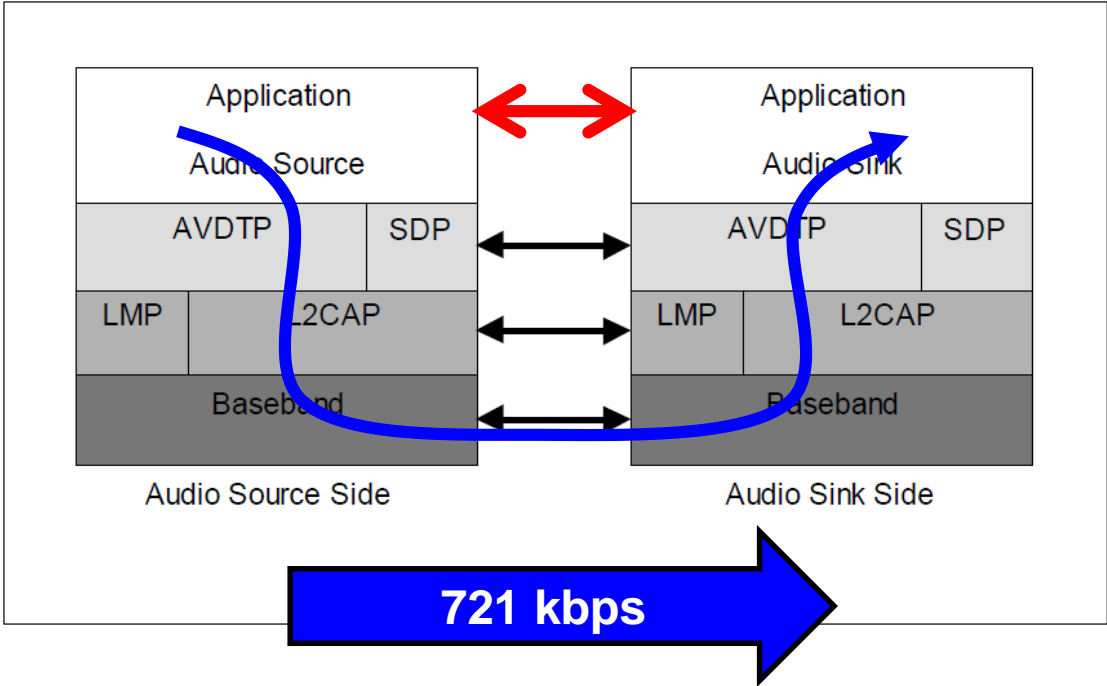

# Hardware Block for IC

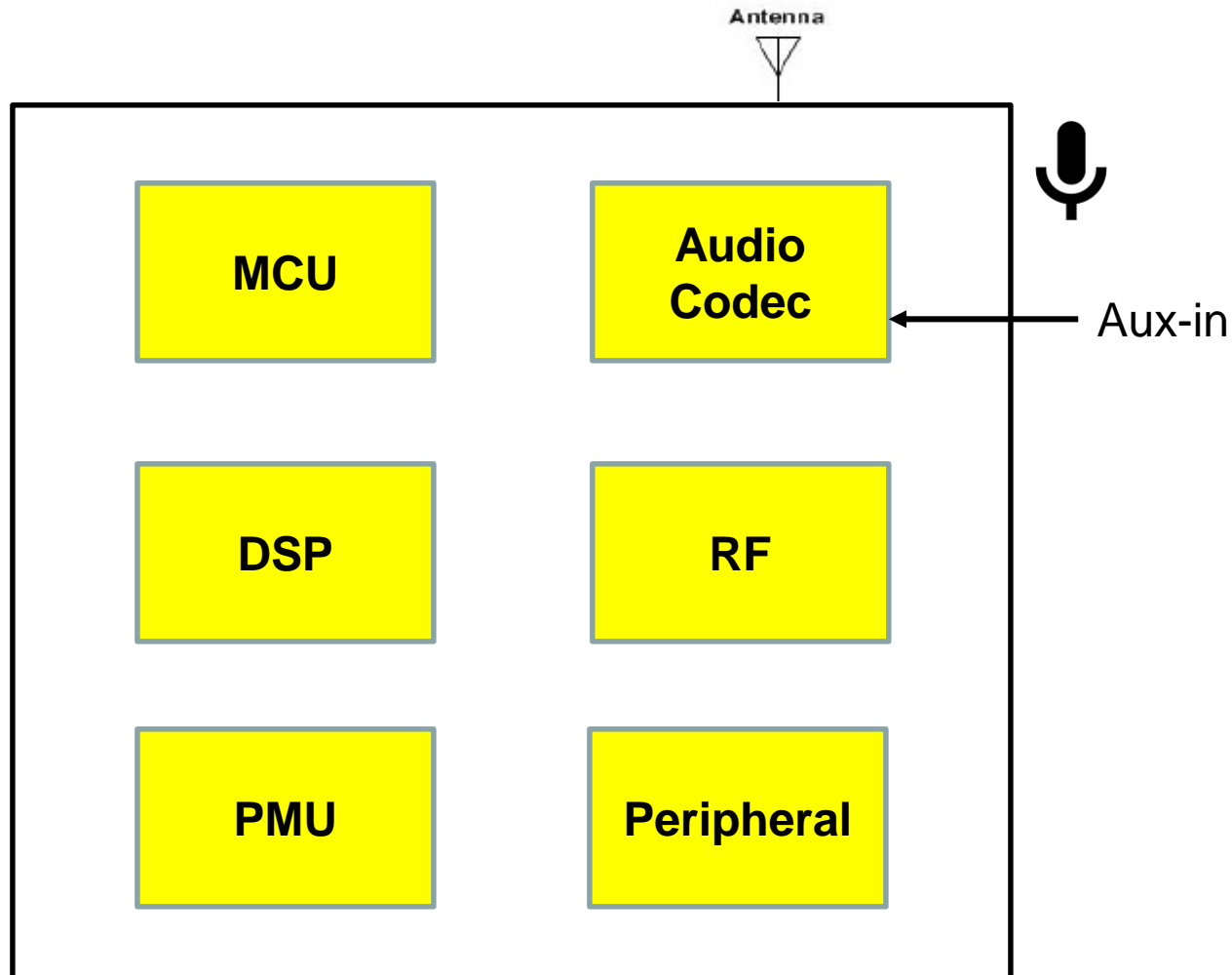



# Bluetooth® Profile

- **Advanced Audio Distribution Profile (A2DP) – Most common profile for streaming multimedia audio. Streams audio via SBC codec and can support MPEG and AAC compression codec's**
- **Audio Video Remote Control Profile (AVRCP) – standardized remote control profile for TV's, home theater, etc. Commonly used in conjunction with A2DP**
- **Serial Port Profile (SPP) – standard replacement for wireless RS-232 data transmission**
- **Hands-Free Profile (HFP) – Remote phone calls**
- **Phone Book Access (PBA) – Exchange phone-book objects**
- **And More! There are currently over 30 profiles supported by Bluetooth SIG!**

- [Advanced Audio Distribution Profile \(A2DP\)](#)
- [Attribute Profile \(ATT\)](#)
- [Audio/Video Remote Control Profile \(AVRCP\)](#)
- [Basic Imaging Profile \(BIP\)](#)
- [Basic Printing Profile \(BPP\)](#)
- [Common ISDN Access Profile \(CIP\)](#)
- [Cordless Telephony Profile \(CTP\)](#)
- [Device ID Profile \(DIP\)](#)
- [Dial-up Networking Profile \(DUN\)](#)
- [Fax Profile \(FAX\)](#)
- [File Transfer Profile \(FTP\)](#)
- [Generic Audio/Video Distribution Profile \(GAVDP\)](#)
- [Generic Access Profile \(GAP\)](#)
- [Generic Attribute Profile \(GATT\)](#)
- [Generic Object Exchange Profile \(GOEP\)](#)
- [Hard Copy Cable Replacement Profile \(HCRP\)](#)
- [Health Device Profile \(HDP\)](#)
- [Hands-Free Profile \(HFP\)](#)
- [Human Interface Device Profile \(HID\)](#)
- [Headset Profile \(HSP\)](#)
- [Intercom Profile \(ICP\)](#)
- [LAN Access Profile \(LAP\)](#)
- [Message Access Profile \(MAP\)](#)
- [Object Push Profile \(OPP\)](#)
- [Personal Area Networking Profile \(PAN\)](#)
- [Phone Book Access Profile \(PBAP, PBA\)](#)
- [Serial Port Profile \(SPP\)](#)
- [Service Discovery Application Profile \(SDAP\)](#)
- [SIM Access Profile \(SAP, SIM, rSAP\)](#)
- [Synchronization Profile \(SYNCH\)](#)
- [Video Distribution Profile \(VDP\)](#)
- [Wireless Application Protocol Bearer \(WAPB\)](#)

# Bluetooth® Stack Structure

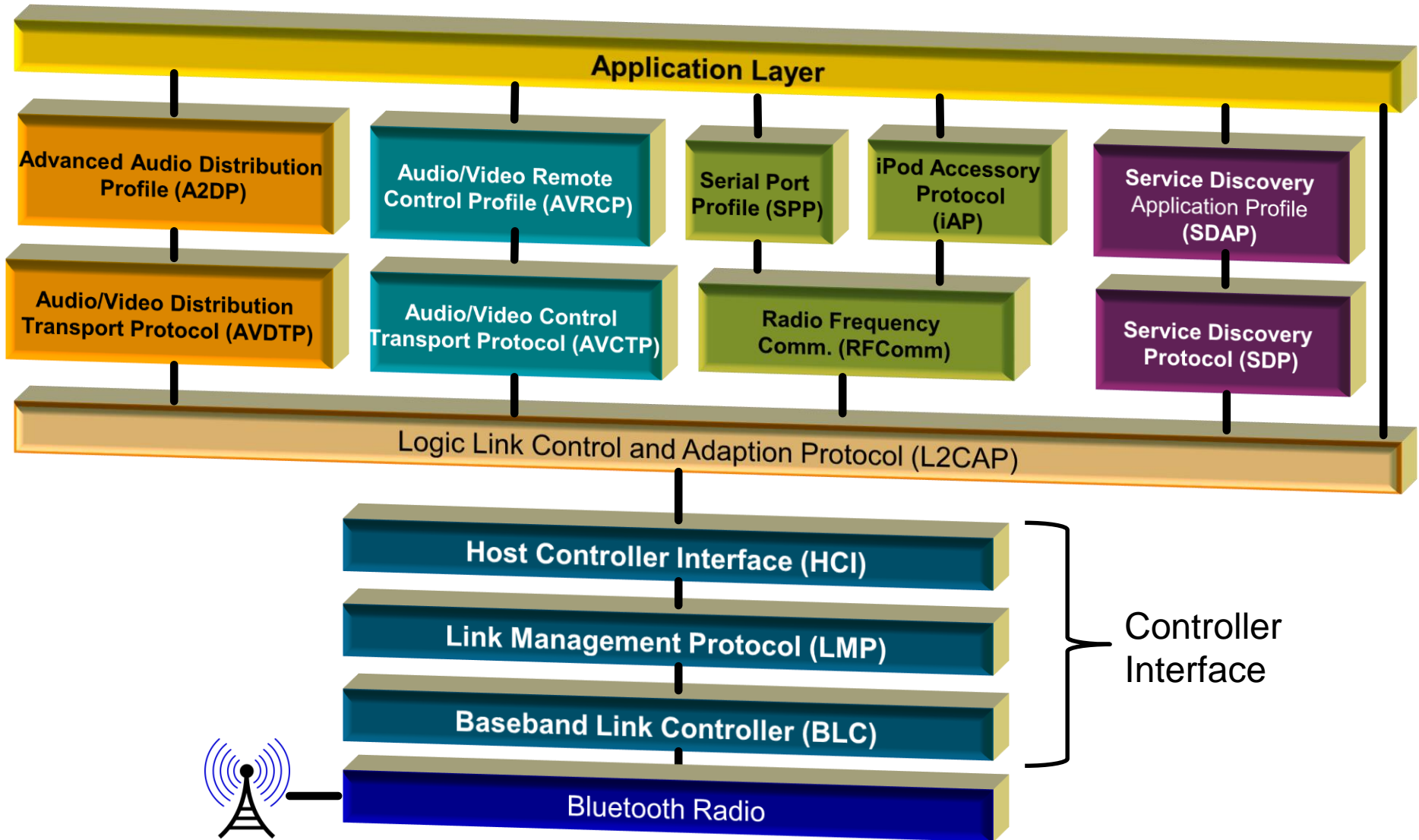

# Bluetooth® Stack

- Defines how a device uses the Bluetooth protocol
- Specifies communication behavior between 2 Bluetooth enabled devices
- Built on Bluetooth core stack
  - Wide spread integration and interoperability
- **Example Profiles**
  - Serial port profile
  - Phone book access profile
  - Audio control and distribution
  - Hands-free profile

## Bluetooth Protocol Stack

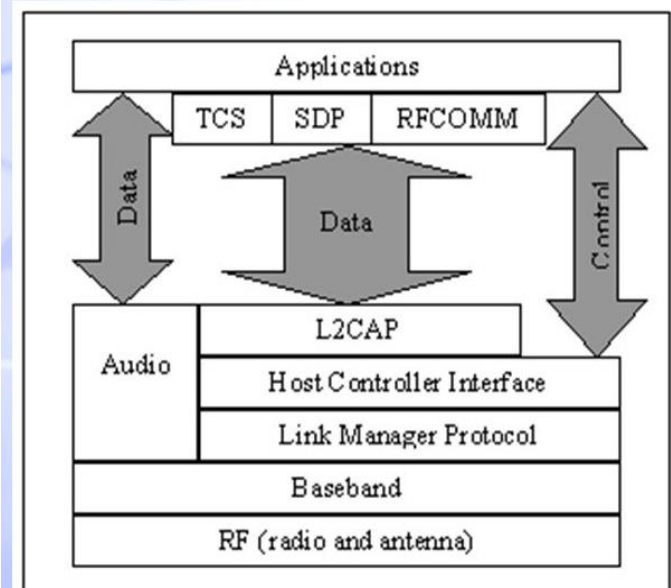

## Bluetooth Stack Profile Versions

Profile	Version	Supports
A2DP	1.3	Audio Streaming
AVRCP	1.5	Remote Control
SPP	1.2	Serial Data
SDP	1.1	Device Detection

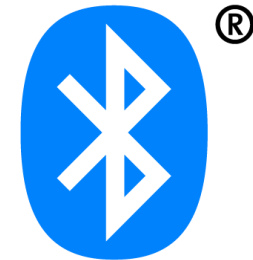

Protocols
HCI
L2CAP
LMP
RFCOMM
AVCTP
AVDTP

Decoders
SBC
AAC
LDAC

Special Applications
Bluetooth Audio (SBC or AAC)
Remote Control advanced features
Multiple Connections
Serial Data Communication (w/Audio)
Modular Radio Interfaces
Hands-Free and Phone Book Access

- **Host**

- Logic Link Control and Adaptation Protocol (L2CAP)
- Service Discovery Protocol (SDP)
- Host Controller Interface (HCI)

- **Controller**

- Link Management Protocol (LMP)
- Baseband Link Controller (BLC)
- Bluetooth Radio

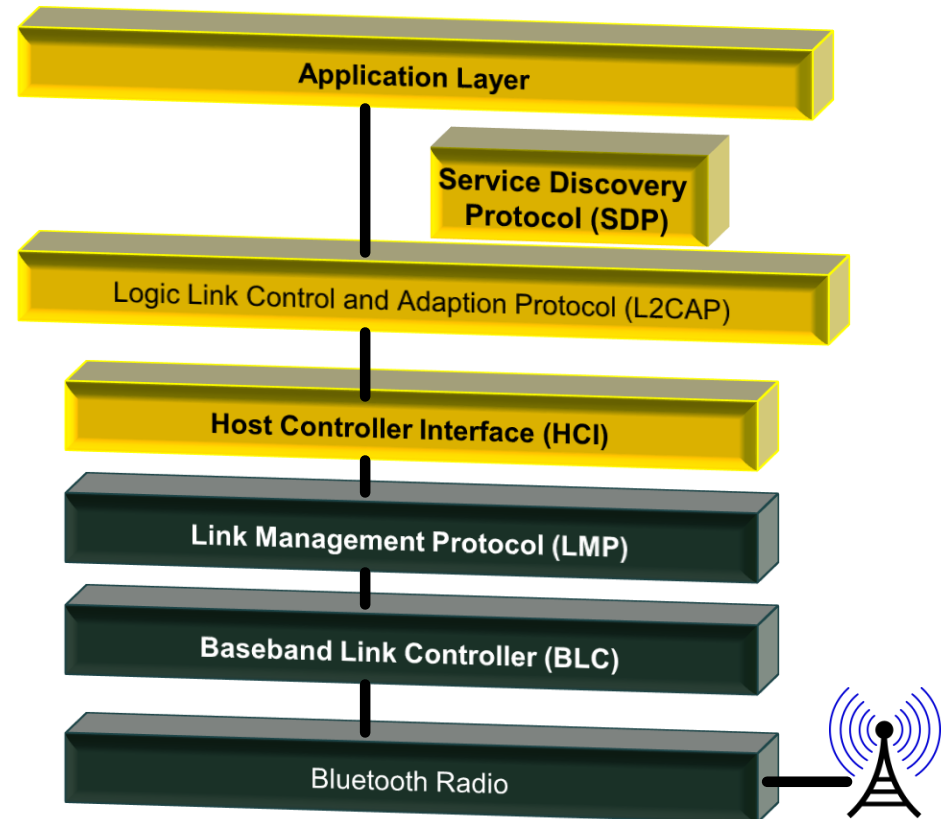

# Audio Applications



Stereo Speaker

Mono Speaker



Neckband



Key feature:  
**beam-forming NR/EC**



Stereo Headset



Soundbar

Key feature: **latency**



Mono Headset

# Target Applications

- **Stereo Headset**

- Earbuds, sports headset, headphones and neckbands
- Our small form factor (chip-down) implementation fits into tight spaces



- **Speaker**

- Portable speakers, outdoor multiple speakers
- Pre-certified modules enable quick time to market with low risk



- **Professional Headset**

- High quality voice headsets, conference room speakerphones
- Suitable for both SoC and modules





**MICROCHIP**

# **Bluetooth® Profiles and CODEC**



- **Advanced Audio Distribution Profile (A2DP v1.3)**
  - Distribution of high-quality audio
  - Stereo or mono streams on ACL channels
  - Includes mandatory support for the low-complexity SBC codec
- **Audio/Video Distribution Transport Protocol (AVDTP)**
  - Negotiation, Establishment and Transmission of A2DP links
  - Defines message formats for A/V streams

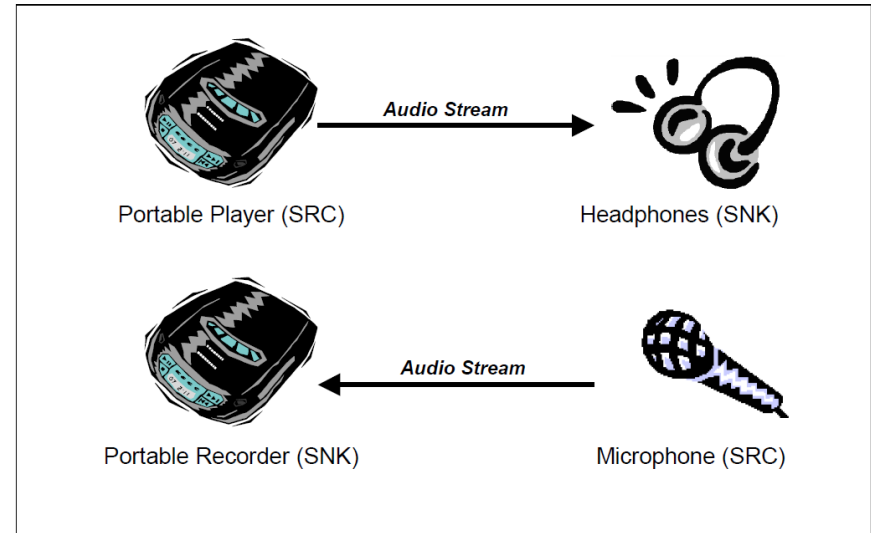

*Example of Configuration*

- **A2DP v1.2**

- Advanced Audio Distribution Profile
- Supports streaming of mono/stereo audio
- Sink (SNK) decodes stream
- Source (SRC) encodes stream
- Maximum bandwidth – 721 kbps
- Typically 44.1 kHz/16 bit/stereo playback

Example of configurations illustrating the roles for A2DP



- **Codecs used**

- SBC (mandatory)
- Support for optional/proprietary codecs like AAC, LDAC, MP3
- Optional codecs to be supported by both sides of connection
- Codec negotiation before establishing stream by transport layer

# Sub Band Codec (SBC)

---

- **One of several codecs available for A2DP transmission**
- **Support is mandatory**
- **44.1 kHz sampling frequency**
- **Stereo support**
- **Low complexity, medium bit rate, medium quality**
- **Royalty free to use with Bluetooth®**

# Audio Decoders

- **A2DP supports multiple audio coding standards**
- **SBC decoder is mandatory**
- **Supported audio decoders are**
  - SBC
  - AAC
- **Optional decoders are**
  - MP3
  - Apt-X
  - LDAC
- **Generally decoding is NOT done in the native audio format**
  - Transcoding from native format to SBC creates some loss



- **A2DP profile APIs**

- Initialization
- Event handler/callback
- Connect
- Disconnect

- **A2DP manager**

- Manages the state structure
- Uses APIs above
- Part of the application source code

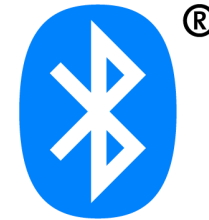

# AVRCP: Bluetooth® Remote Control Profile

- AVRCP v1.5
  - Audio/Video Remote Control Profile
  - Media Player Control
    - Track Play/Pause
    - Track Previous/Next
    - Volume Up/Down
  - Media Track Metadata
    - Track title, artist, album, genre
    - Track number, count, duration
    - Command to display metadata



# AVRCP Function

- Typically used with A2DP\*
- For controlling audio/visual devices over Bluetooth®
- **Controller (CT) sends command to Target (TG)**
  - CT: PC, Docking Station
  - TG: Audio Player, TV, Smart Phone

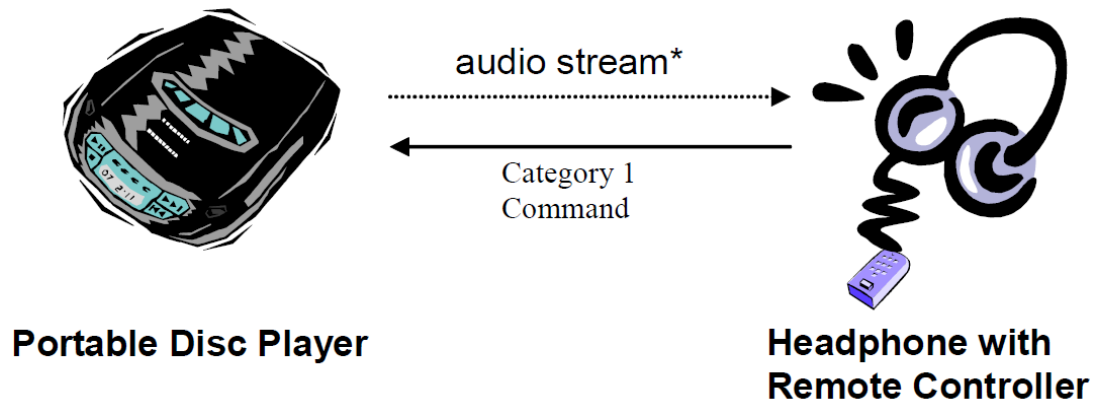

- **Serial Port Profile (SPP v1.2)**
  - Emulate serial communication
  - Uses legacy serial communication ports
  - Very low code and processing overhead
  - Good for data-only communication
  - Uses RFCOMM protocol
  - Special Bluetooth stack - FREE



- **Apple controls proprietary data links to the iPhone®/ iPad®/ iPod®**
  - Bluetooth
    - Exceptions are HID and Audio profiles
- **‘Made for iPod’ program**
  - No support for SPP
  - Instead, define iAP1/iAP2 protocols
  - All accessory connections **MUST** have an Apple authentication chip
  - MFI requires project plan to be approved
    - Ensure quality customs experience
    - Self test for interoperability & compatibility

- **HFP v1.6, HSP v1.2**

- Hands-free profile, headset profile
- Narrowband and wideband voice calls
- Remote control of mobile phone (only HFP)
  - HSP allows answer/end calls + volume control
- Audio gateway (AG): input/output gateway, e.g. mobile, PC
- Hands free unit: AG's remote audio input/output mechanism

- **Voice Codecs**

- CVSD (mandatory)
  - Continuous Variable Slope Delta Modulation
  - Narrowband speech codec
- mSBC (optional)
  - Mono-aural configuration of SBC at 16KHz
  - Supports Wideband speech

Example of configurations illustrating the roles for HFP

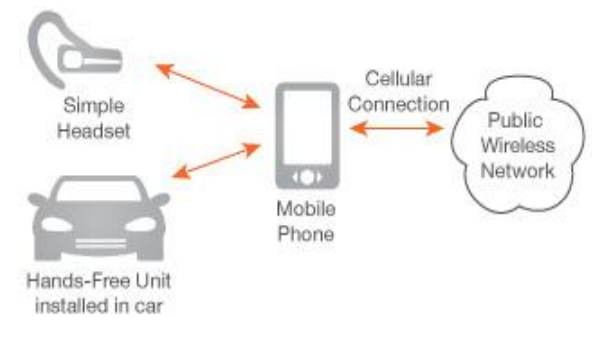

# Hands-Free Profile Demo

- Defines minimum set of functions such that a mobile phone can be used in conjunction with a hands-free device
- Remote control of the mobile phone by the hands-free device
- Voice connections between the mobile phone and the hands-free device

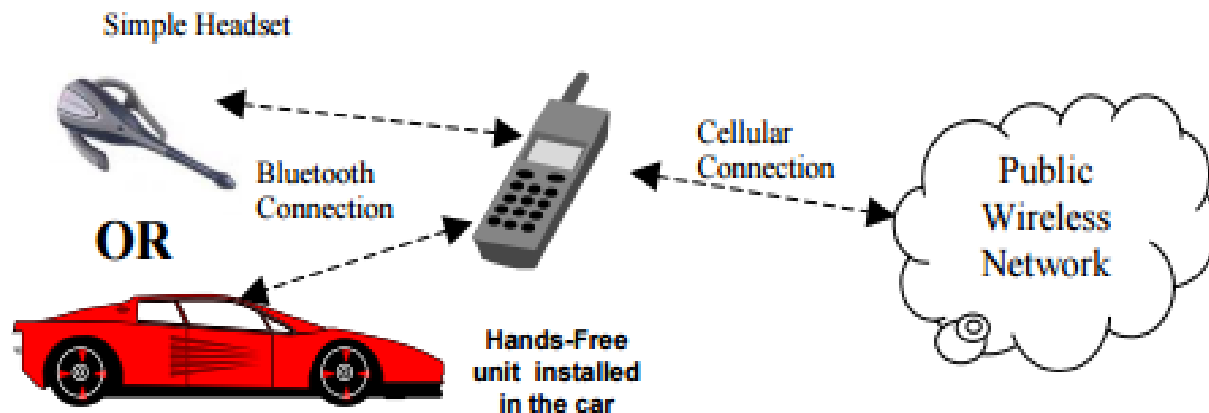

# Bluetooth® Phone Book Access Profile (PBAP)

- **PBAP specification defines the procedures and protocols to exchange Phone Book objects between devices**
- **The PBAP defines two roles:**
  - Phone Book Server Equipment (PSE) – contains the source phone book objects (mobile phone)
  - Phone Book Client Equipment (PCE) – retrieves phone book object from the PSE

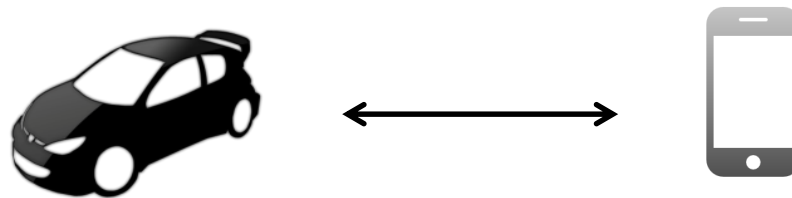

- **Music quality**
  - Good quality with SBC codec
  - More robust AAC codec available
- **Basic controls**
  - Intuitive but vary with handset
- **Interaction with handset**
  - Most audio applications support Bluetooth<sup>®</sup> and controls

# Bluetooth® Pairing

- **Three step process**

- Device discovery
  - Slave must be discoverable
- Pairing
  - Requires both devices to support the same profile
- Authentication
  - Optional
  - Required if any one of the two devices demands authentication



- **Information Exchanged**

- Device Name – *up to 248-bytes*
- Device Address – *48-bit, Public*
- Link key – *128-bit, Private*
- PIN – *16-bit – 128-bit, Security Key*



# Bluetooth® Stack Libraries

- **Bluetooth Stack**

- Bluetooth Stack - lib\_bluetooth\_vx.y.a
  - Distributed as archive/library (.a) file
  - SPP only version available, harmony compliant
  - Includes host and controller stacks
- Bluetooth Controller Driver - btport\_csr881x.c
  - Modular driver architecture, prototype provided at application level
  - HCI interface uses UART interface
  - Stack independent
  - CSR881x
  - RDA5876
  - More Bluetooth controllers in future

- **Audio Decoder Libraries**

- Libraries available for a fee
  - Stack independent
  - SBC - lib\_sbc\_decoder\_vx.y.a
  - AAC - lib\_aac\_decoder\_vx.y.a
  - MP3 - lib\_mp3\_decoder\_vx.y.a
- acoder Libraries



**MICROCHIP**

# **DSP Capabilities**



- **Crisp, clear audio for natural voice communications**
  - Removes ambient noise, call interferences
- **High Definition Clean Audio (HCA)**
  - Noise reduction(NR)
    - **Stationary noise suppression**
  - Echo Cancellation(EC)/ Suppression(ES)
    - **Linear/ non-linear echo cancellations**
  - Comfort noise insertion for MIC paths
    - **Insert comfort noise to maintain stable noise level**
  - 5-band EQs for SPK/MIC paths
    - **Compensate frequency imperfection**
  - High-pass filter for SPK/ MIC paths (HPF)
    - **Remove low-frequency board/background noise**

- **Enhances audio listening experience**
  - 5-band EQ for SPK
  - Multi-band dynamic range compression (MB-DRC)
  - Virtual bass (VB) enhancement
    - Enhance the bass using psychoacoustic algorithm
  - Audio widening(AW)
    - Makes close speakers sound like far-away placed
- **I<sup>2</sup>S Configurations**
  - Master/ Slave modes
  - External/ Internal MIC ADC
    - **Adopt DAC-only codec/ DSP or both external ADC/ DAC**

# High Pass Filter (HPF)

- **Filters unwanted low-frequency signals**
  - Eg. board noise, current noise, wind noise etc.
- **Low latency IIR filter**
- **7 selectable cut-off frequencies**

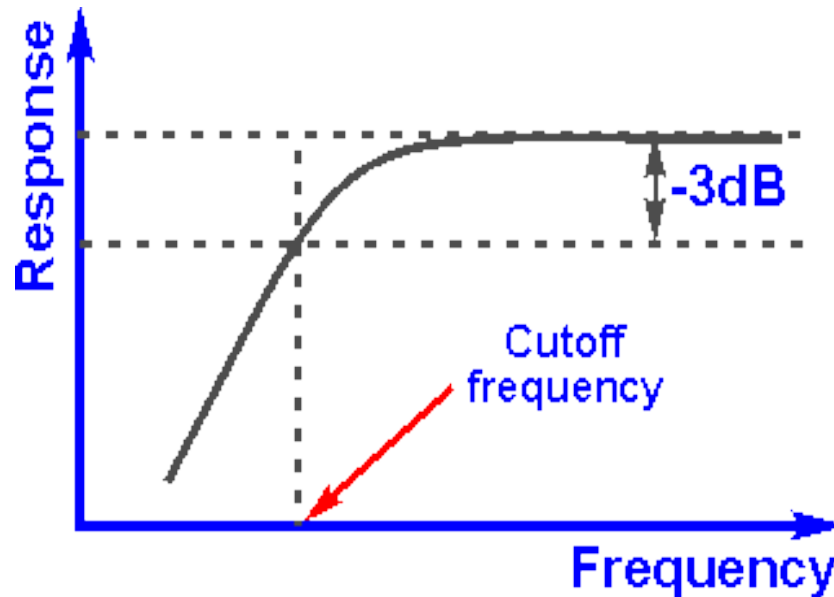

# Acoustic Echo Cancellation

- **Why Acoustic Echo Cancellation (AEC)**
  - Sound of speaker picked up by mic in same room
  - Delayed sound heard as echo at the “Far End”
  - Exists in any “duplex” communication system

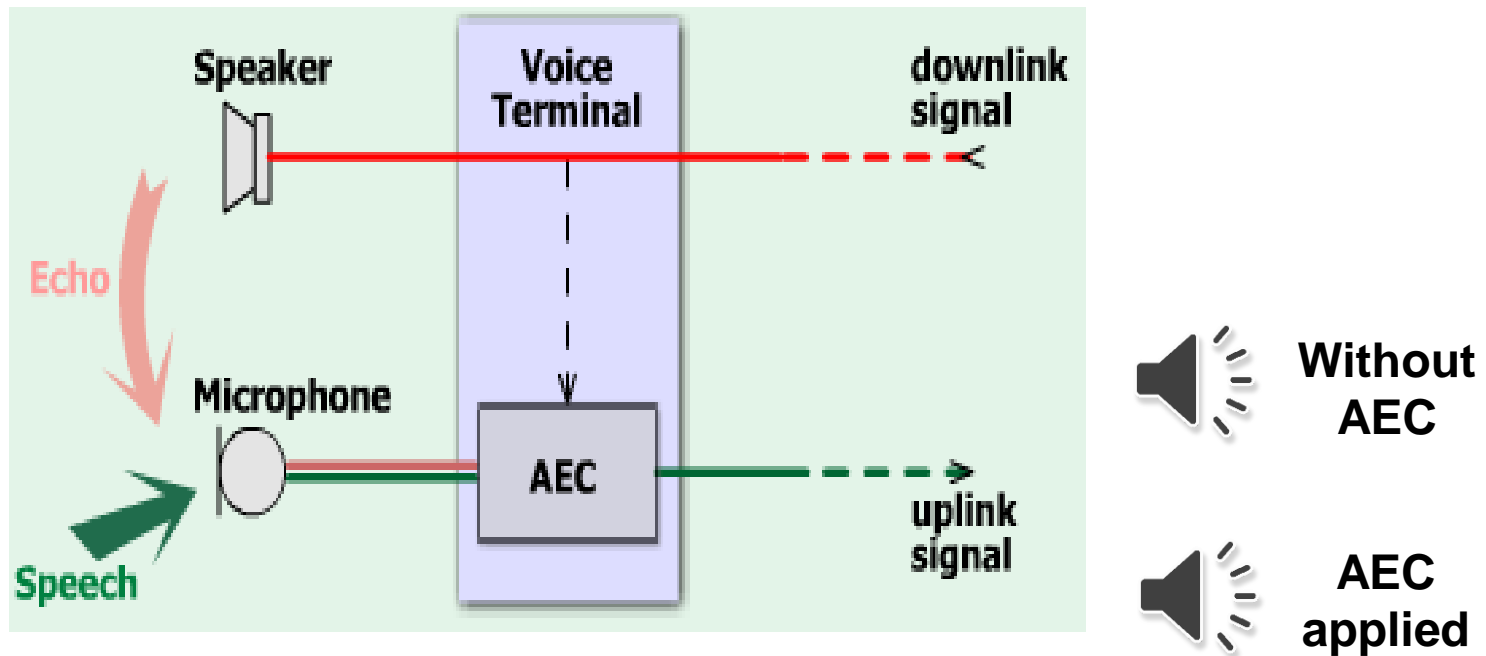

# Basics of AEC

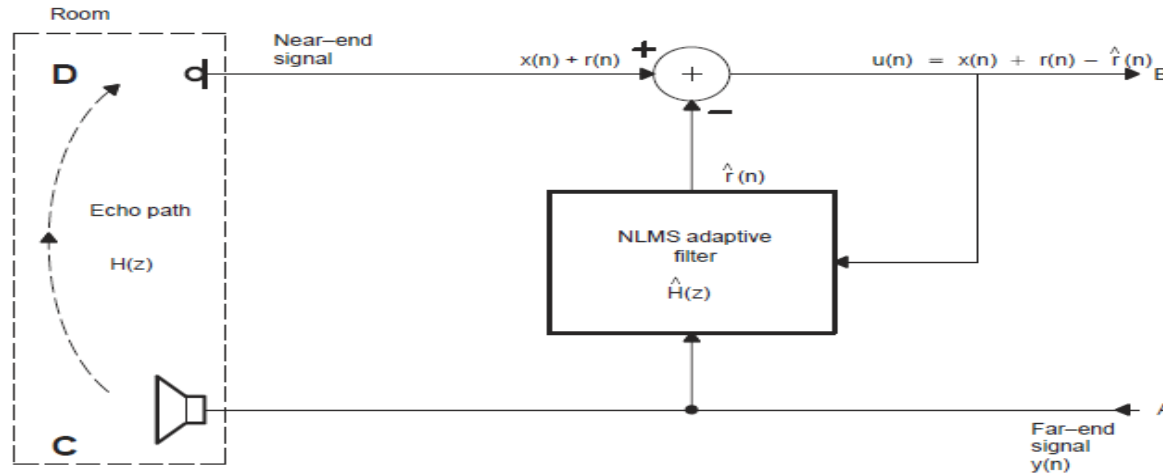

Figure 1. Echo Canceller Configuration

- **Linear echo cancellation (represented above)**
  - Adaptive filter to track Echo Path change over time
- **Acoustic echo suppression**
  - For residual echo due to non ideal hardware components
- **Voice Activity Detection**
  - Controls the level of full duplexity

# Noise Reduction

- **Remove stationary ambient noise**

- E.g. fan noise, white noise, engine noise, etc
- Suggested range 12 db ~ 21 db for MIC/SPKR path
- Higher suppression impacts quality in low SNR environment

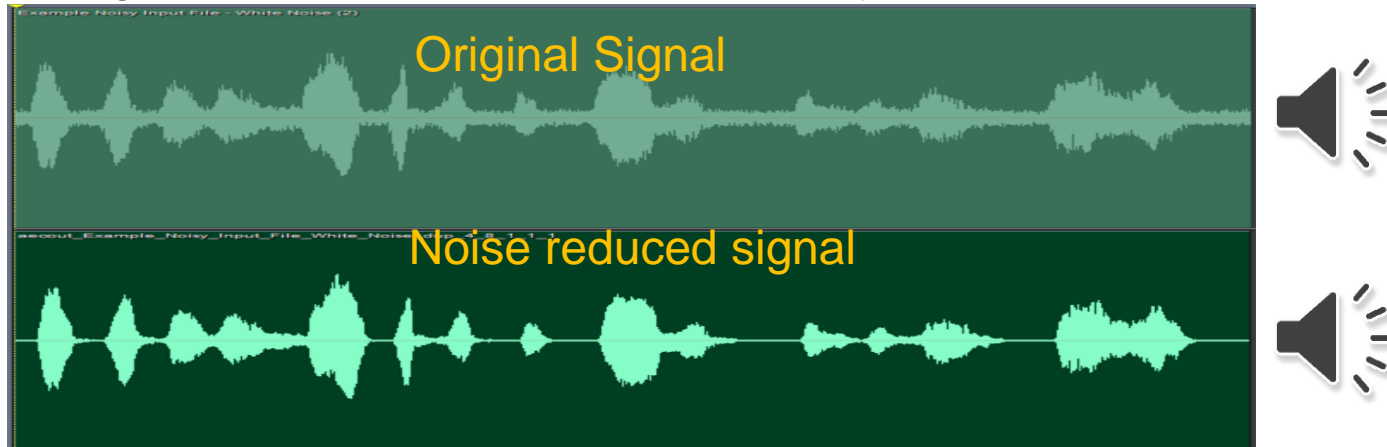

- **Dual mic solution (Silicon only)**

- Headset only applications
- Primary mic closer to the desired source
- Secondary mic captures ambient noise

# Equalization (EQ)

- 5 band Parametric Equalizer
- Compensates for imperfect frequency response
- Configurable for voice and audio modes
- Features :
  - Turn on/off EQ function
  - Adjustable gain, center frequency, Q
  - Number of bands (1-5)
  - Frequency response representation
  - Save/Load frequency response to file
  - Compare frequency responses
  - Save coefficients to file

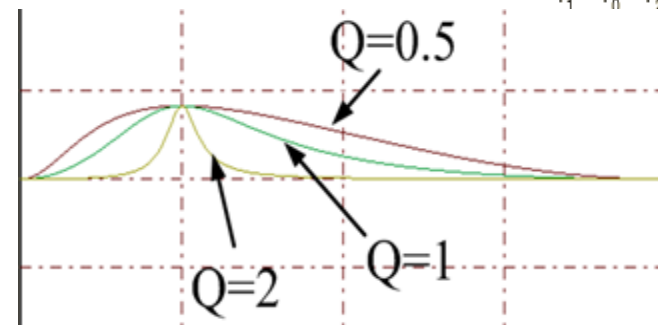
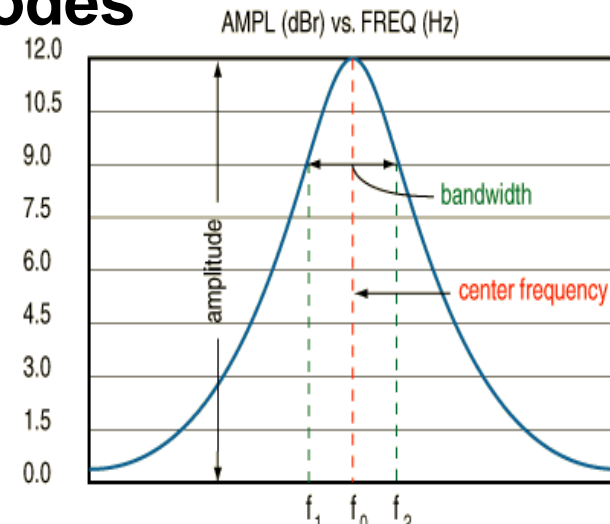



**MICROCHIP**

# **Design Procedure**



# Design Procedure

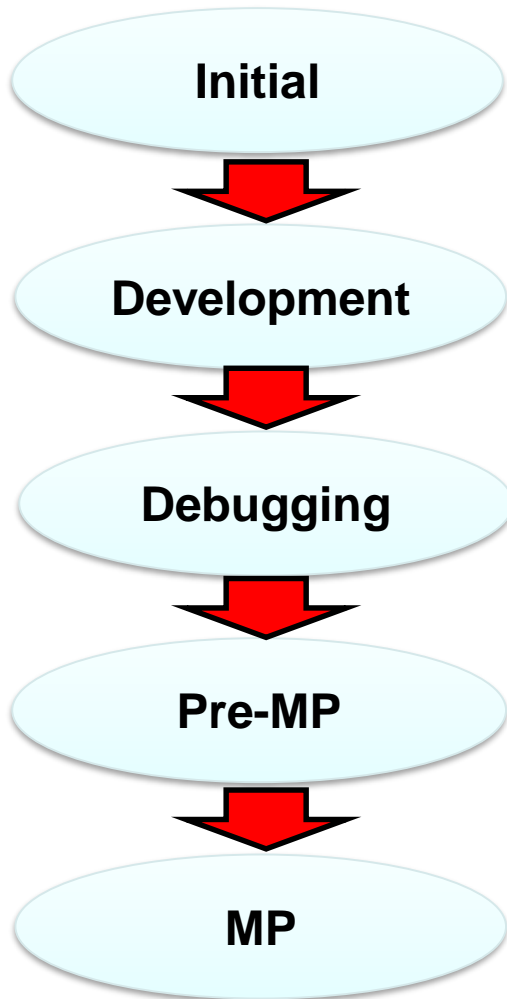

- ✓ Part choice
  
- ✓ Implementing features
- ✓ Prototype board design
  
- ✓ Improving audio quality
- ✓ Tuning-up noise
  
- ✓ BT SIG certification
- ✓ RF certification
  
- ✓ Audio/RF Calibration
- ✓ Input Bluetooth mac
- ✓ Download F/W

# Design Flow

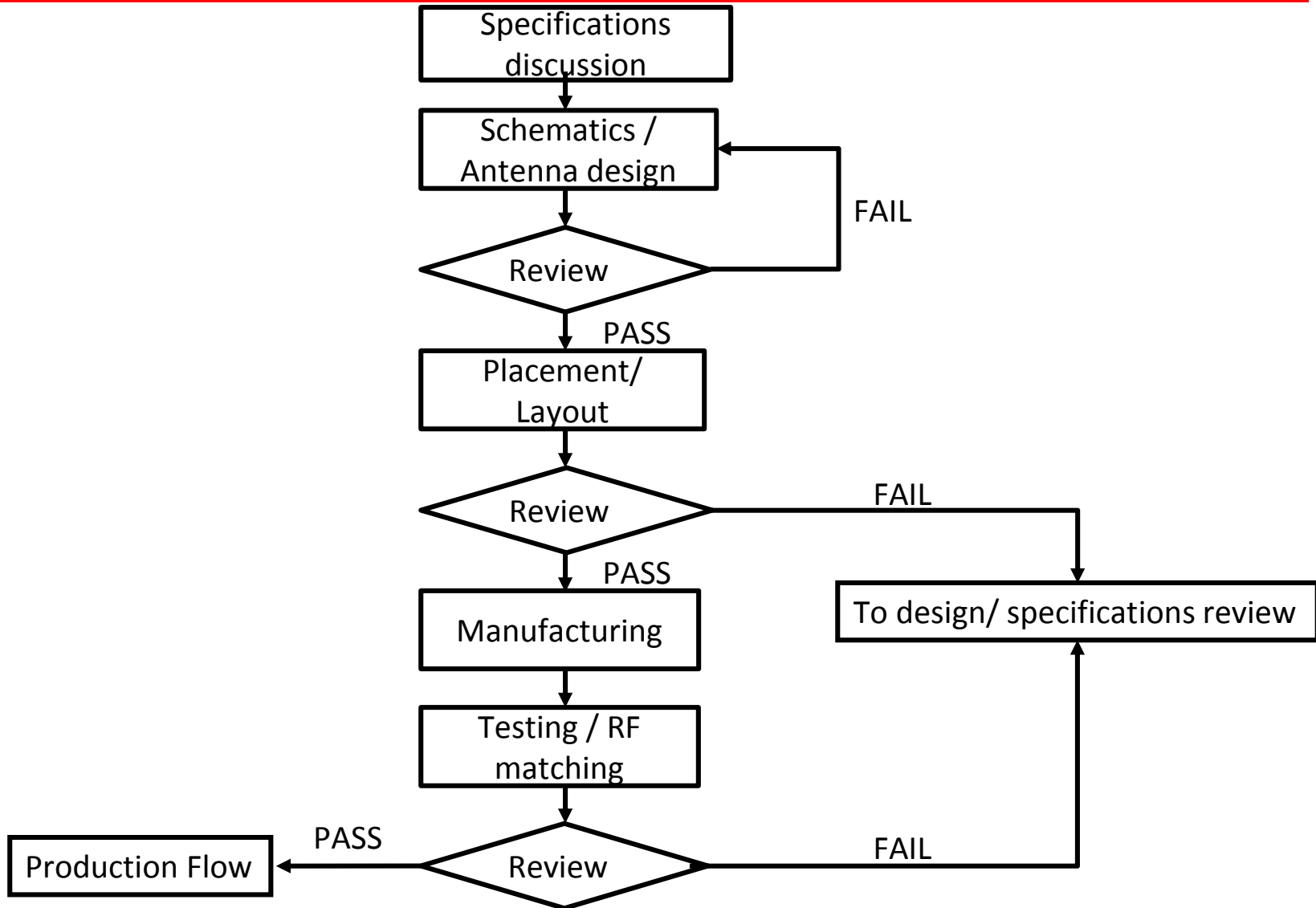



**MICROCHIP**

# **Antenna Design**



# Antenna Design - PCB

**Environment:**

- GND area
- Spacing to GND
- Battery location
- Components location
- Antenna location
- Keep-out area
- PCB Thickness

**Antenna Variants based on simulation**

**Verification:**

- Antenna matching
- Return Loss < -10 dB
- 3D pattern
- Gain
- Efficiency

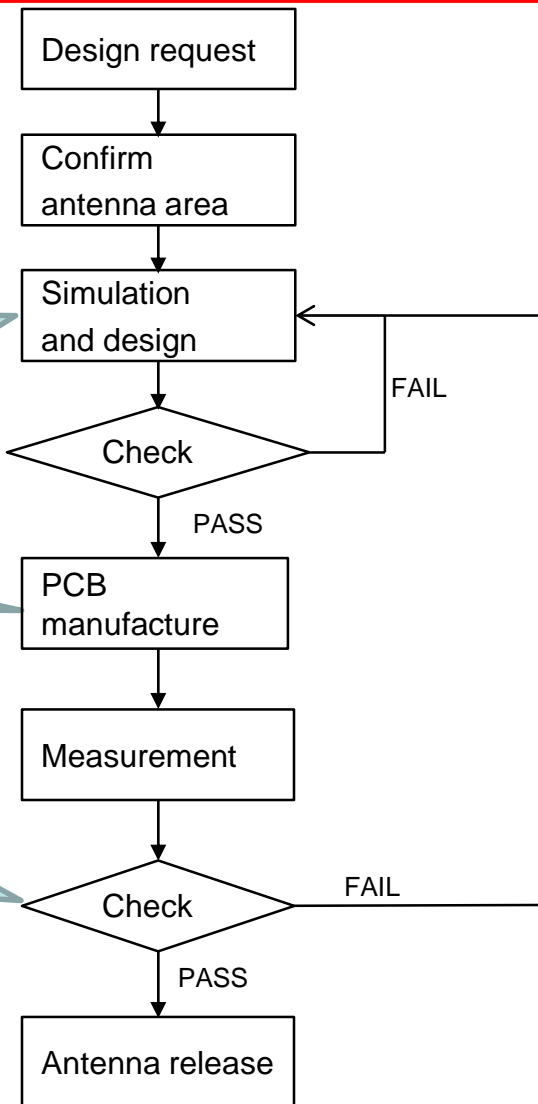

# Antenna Design and Simulation

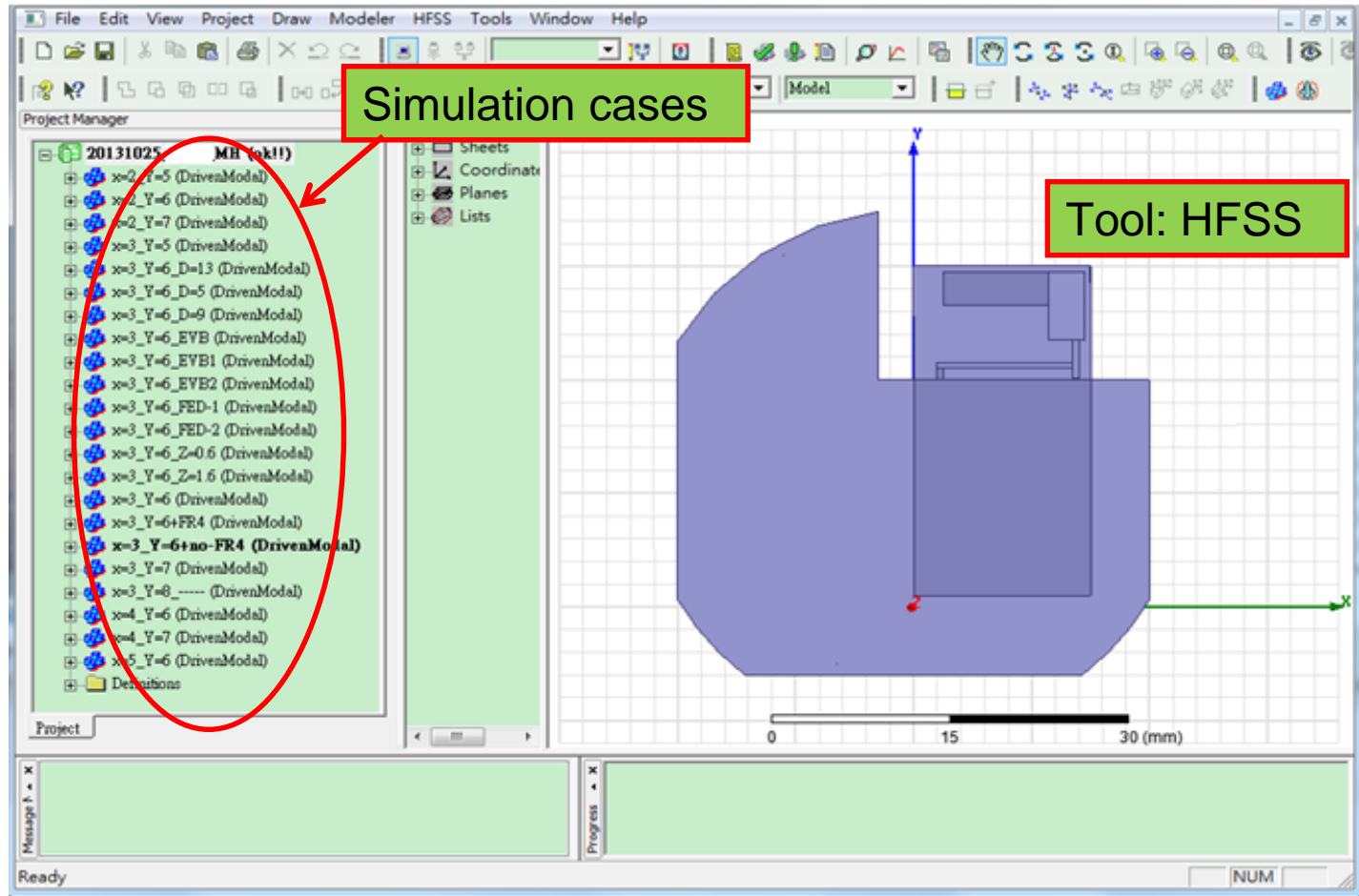

**Run simulation for different cases to determine the best solution**

# Antenna Placement

- Ideal pattern is disturbed by:
  - Metal parts in vicinity
  - Dielectrics
  - Electronics, etc

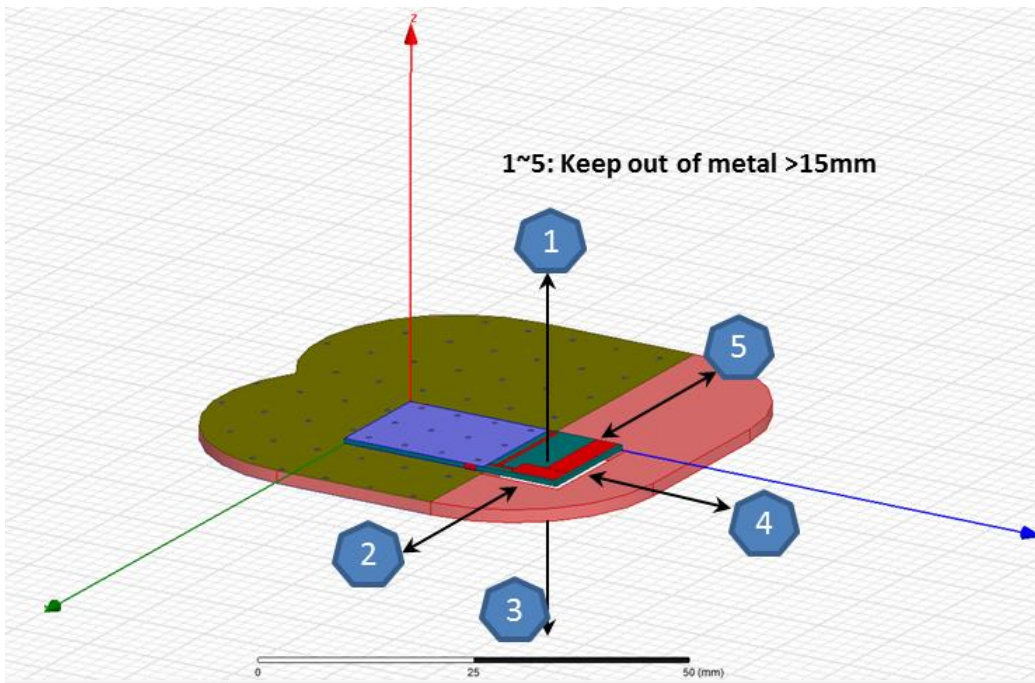

**Module/ Antenna Placement and “Keep Out” Area**

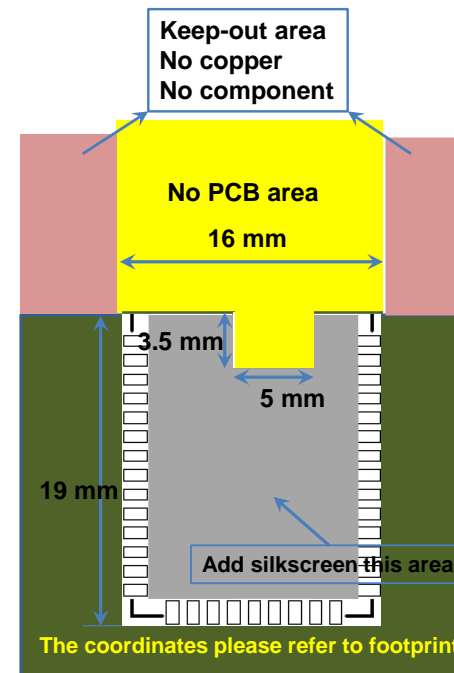

# Module Placement – For Radiation Performance

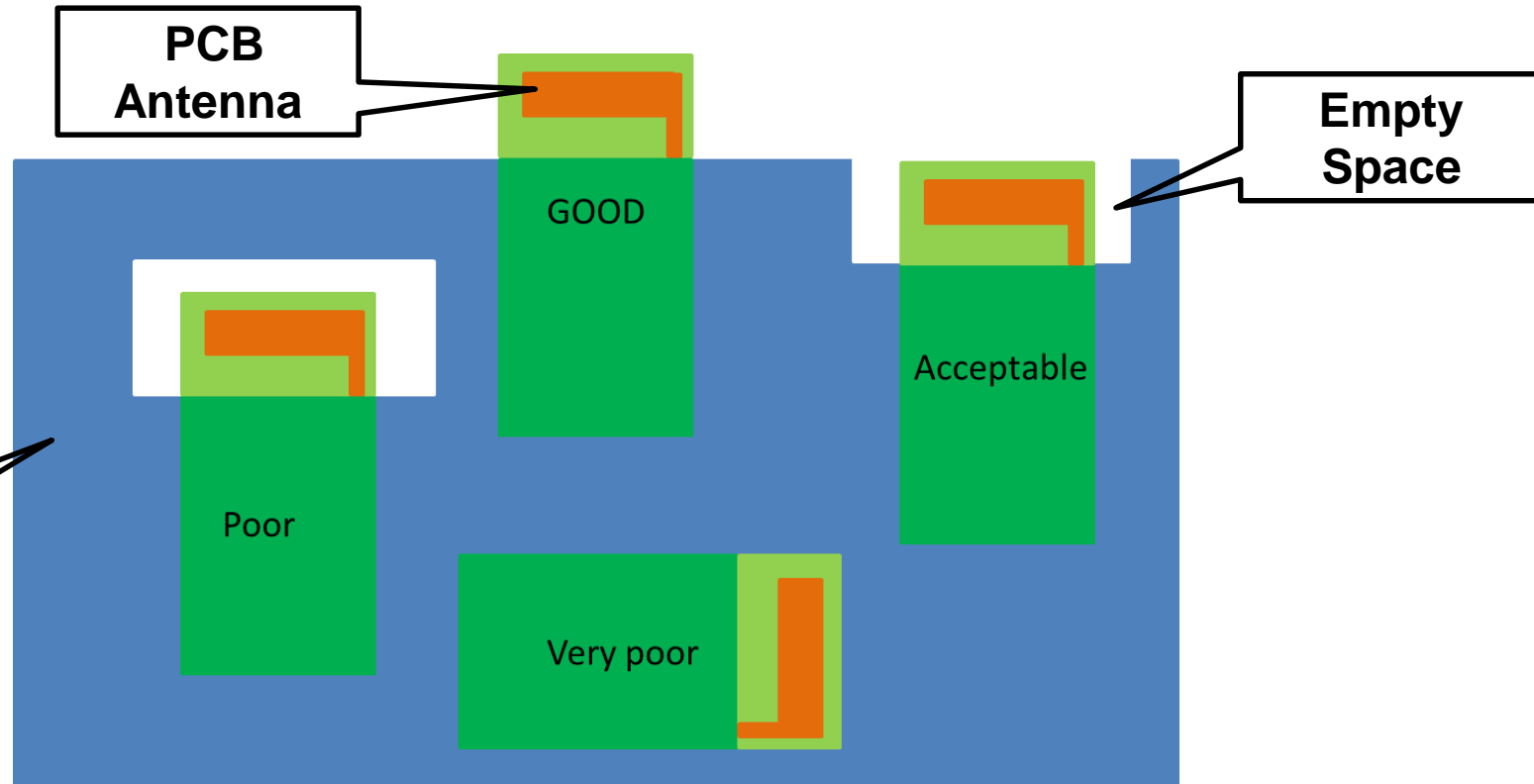

Antenna placement locations should avoid proximity to metal parts and ground planes.



**MICROCHIP**

**Thank you!**

