

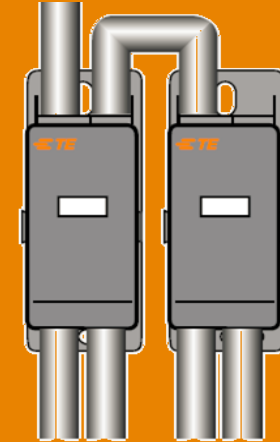

Mouser Webinar

배선 노이즈 방지 커넥터 구조 및
효율적인 제어부 설계 기법 세미나

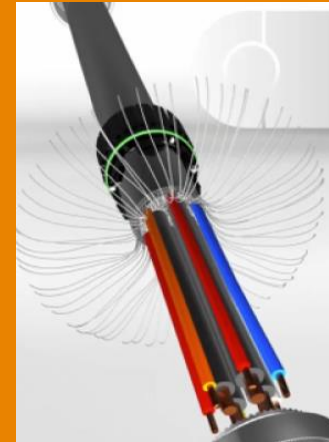

Hong Seung Mo sm.hong@te.com
Sales Manager
TE Connectivity Korea

■ 배선 노이즈 방지 커넥터 구조

■ Transmission Line

전송선 : 정보(에너지)의 전달경로

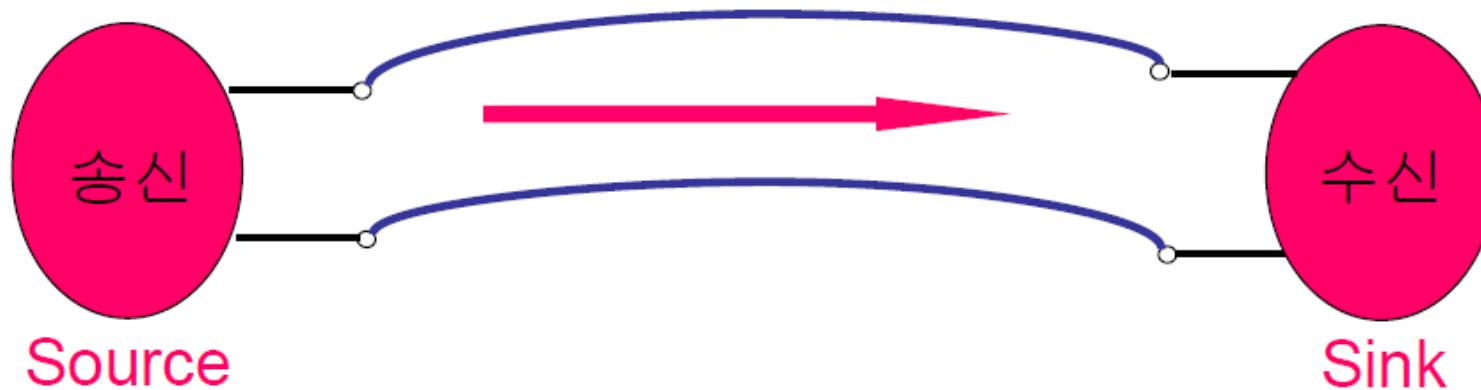

자유공간도 전송선이다!!

■ Transmission Line 의 종류 - 광대역 , 저손실 , 고전력

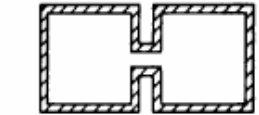
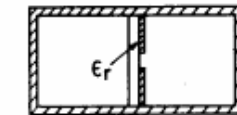
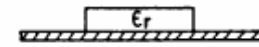
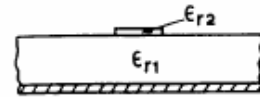
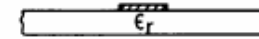
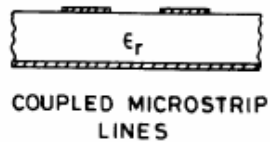
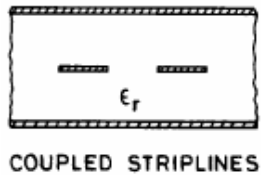
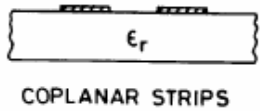
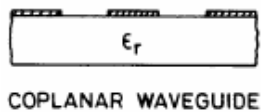
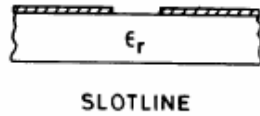
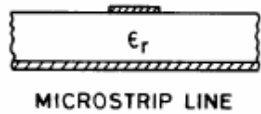
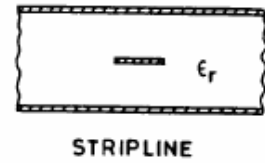
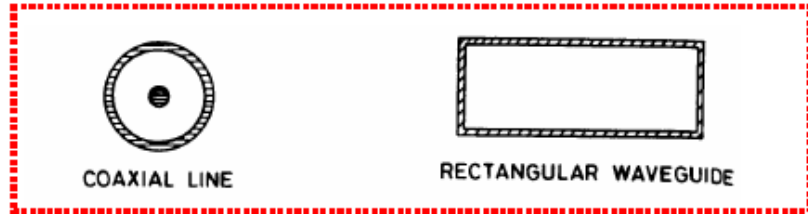

■ Transmission Line 특성 비교

TABLE 2.1 Comparison of Guiding Media and Waveguides

Item	Useful Frequency (GHz)	Impedance Level (Ω)	Cross-Sectional Dimensions	Q Factor	Power Rating	Active Device Mounting	Potential for Low-Cost Production
Rectangular waveguide	< 300	100–500	Moderate to large	High	High	Easy	Poor
Coaxial line	< 50	10–100	Moderate	Moderate	Moderate	Fair	Poor
Strip line	< 10	10–100	Moderate	Low	Low	Fair	Good
Microstrip line	\leq 100	10–100	Small	Low	Low	Easy	Good
Suspended strip line	\leq 150	20–150	Small	Moderate	Low	Easy	Fair
Fin line	\leq 150	20–400	Moderate	Moderate	Low	Easy	Fair
Slot line	\leq 60	60–200	Small	Low	Low	Fair	Good
Coplanar waveguide	\leq 60	40–150	Small	Low	Low	Fair	Good
Image guide	< 300	20–30	Moderate	High	Low	Poor	Good
Dielectric guide	< 300	20–50	Moderate	High	Low	Poor	Fair

Transmission Line 의 특성 임피던스

특성임피던스 $Z_0 = \sqrt{\frac{R + j\omega L}{G + j\omega C}}$

1) 전송선의 손실이 적은 경우 ($R \ll \omega L, G \ll \omega C$)





$$Z_0 \approx \sqrt{\frac{L}{C}} \left[1 - j \left(\frac{R}{2\omega L} - \frac{G}{2\omega C} \right) \right]$$

2) 무손실의 경우 ($R = G = 0$)

$$Z_0 = \sqrt{\frac{L}{C}}$$

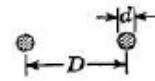
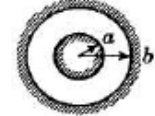
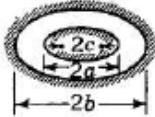
순저항!! 성분

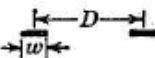
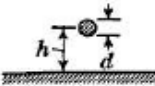
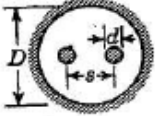
TABLE 2-3. CHARACTERISTIC IMPEDANCES OF SOME COMMON TRANSMISSION LINES

Line	Geometry	Characteristic impedance
Two wire		$Z_0 \approx \frac{\eta}{\pi} \log \frac{2D}{d} \quad D \gg d$
Coaxial		$Z_0 = \frac{\eta}{2\pi} \log \frac{b}{a}$
Confocal elliptic		$Z_0 = \frac{\eta}{2\pi} \log \frac{b + \sqrt{b^2 - c^2}}{a + \sqrt{a^2 - c^2}}$
Parallel plate		$Z_0 \approx \eta \frac{b}{w} \quad w \gg b$
Collinear plate		$Z_0 \approx \frac{\eta}{\pi} \log \frac{4D}{w} \quad D \gg w$
Wire above ground plane		$Z_0 \approx \frac{\eta}{2\pi} \log \frac{4h}{d} \quad h \gg d$
Shielded pair		$Z_0 \approx \frac{\eta}{\pi} \log \left(\frac{2s D^2 - s^2}{d D^2 + s^2} \right) \quad D \gg d, s \gg d$
Wire in trough		$Z_0 \approx \frac{\eta}{2\pi} \log \left(\frac{4w}{\pi d} \tanh \frac{\pi h}{w} \right) \quad h \gg d, w \gg d$

Coaxial Connector 의 임피던스 매칭 설계

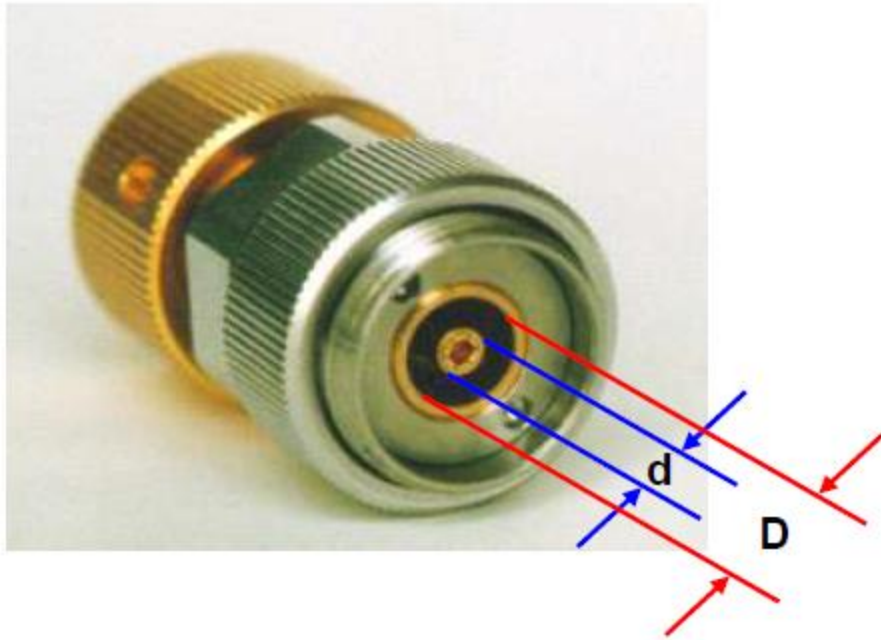

$$Z_o = \frac{1}{2\pi} \sqrt{\frac{\mu}{\epsilon}} \text{Ln}\left(\frac{D}{d}\right) \Rightarrow 50 \approx 60 \text{Ln}(2.3)$$

$$50 \Omega \Rightarrow D = 7 \text{ mm} \Rightarrow d = 3.04 \text{ mm}$$

■ Transmission Line 의 Z_0

- Z_0 determines relationship between voltage and current waves
- Z_0 is a function of physical dimensions and ϵ_r
- Z_0 is usually a real impedance (e.g. 50 or 75 Ω)

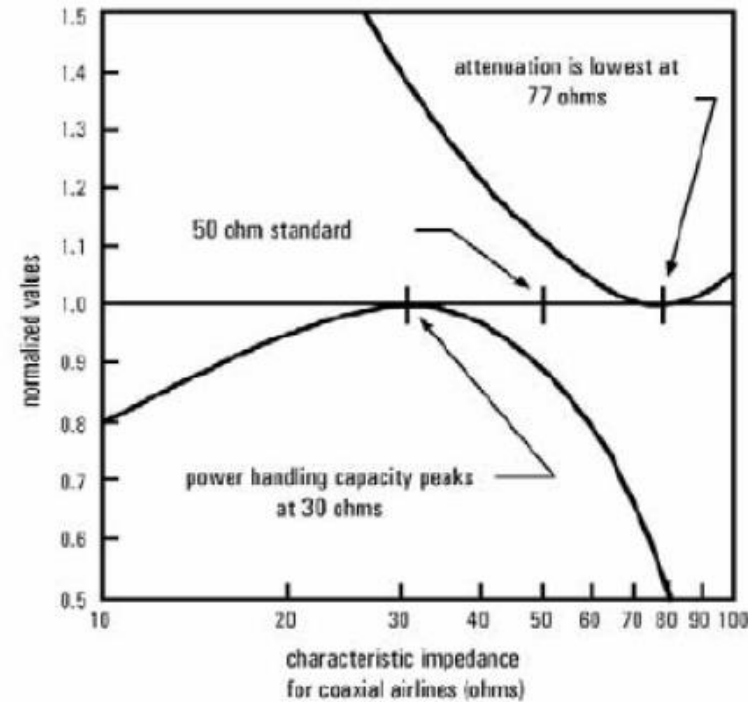
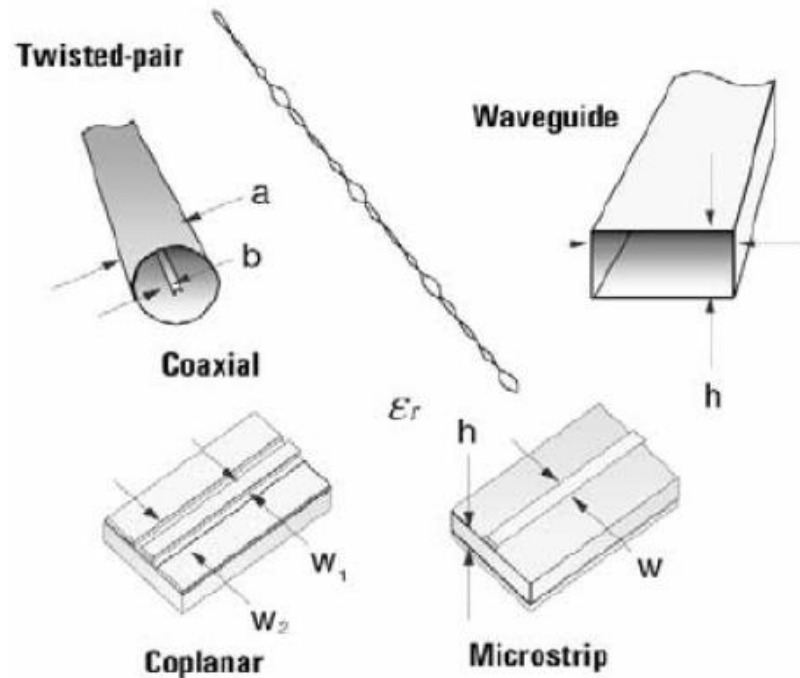

■ Transmission Line Insertion Loss & Return Loss

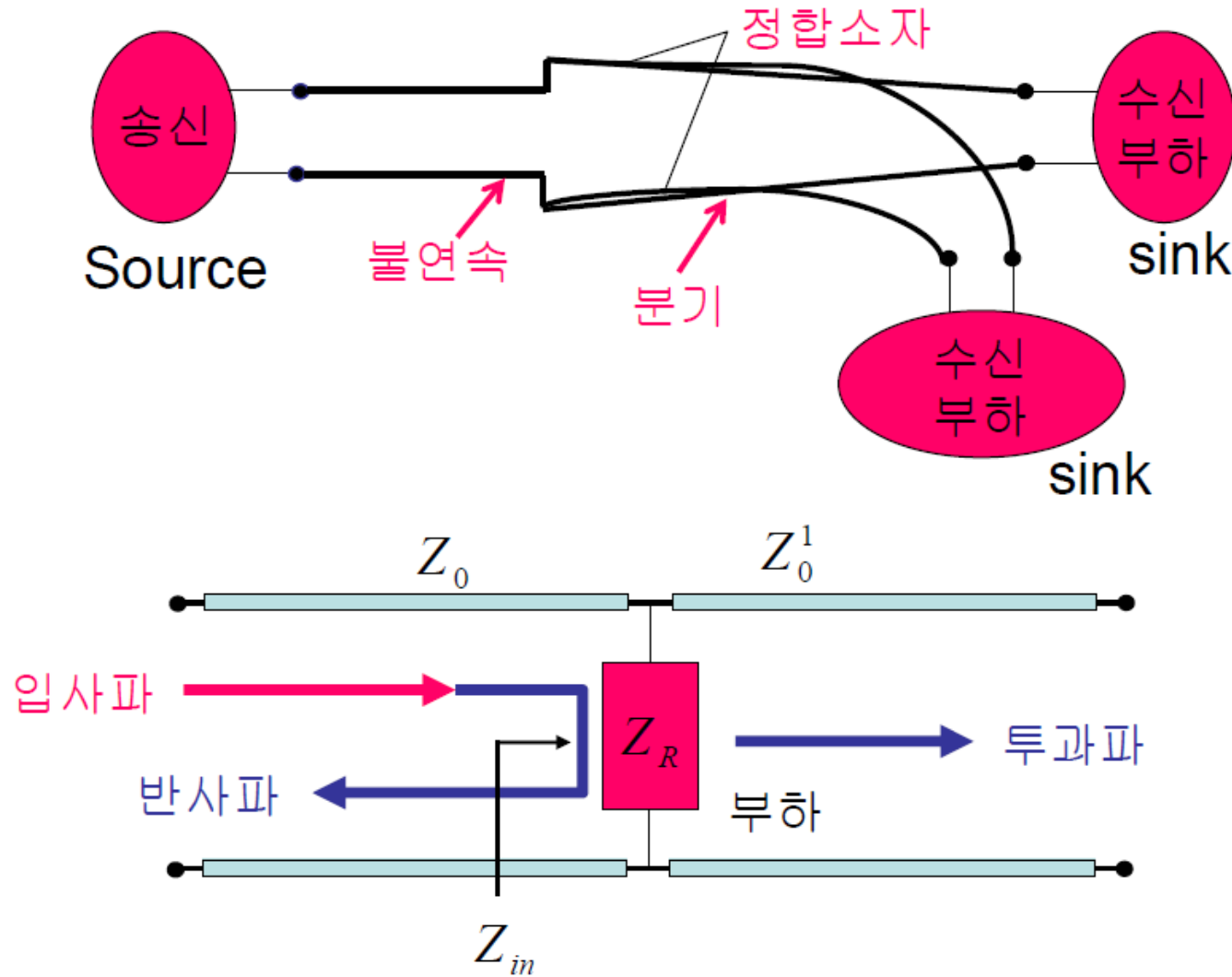

Special Shield Shape for Impedance Matching

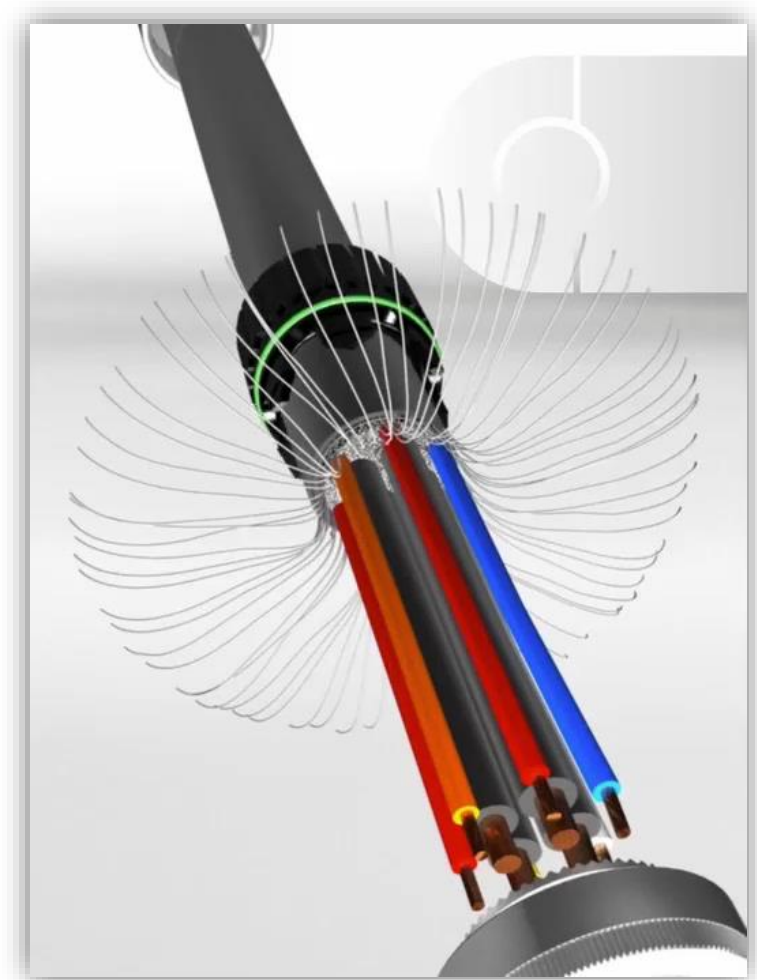
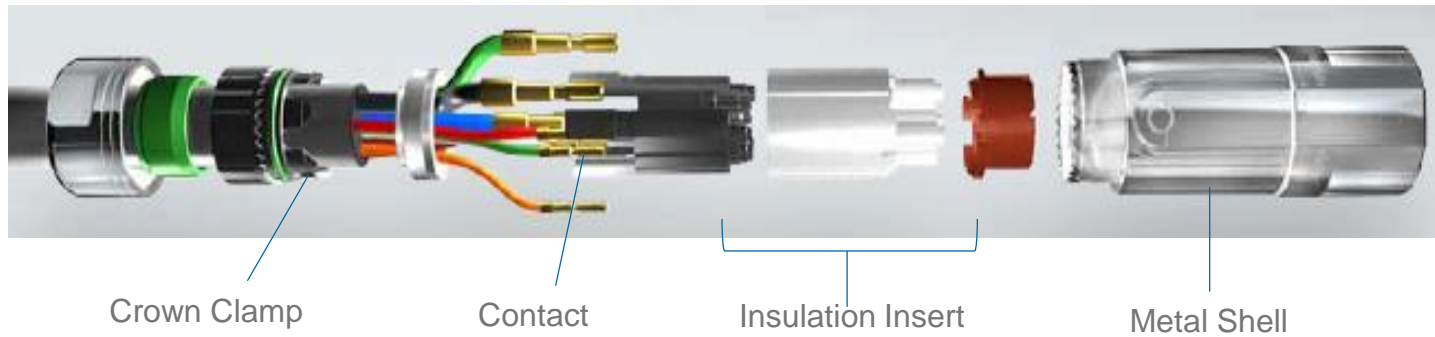

Movie of Crown Clamp

✓ Easy contact assembly / disassembly for Insulation Insert



✓ Crown clamp for shielding wire .

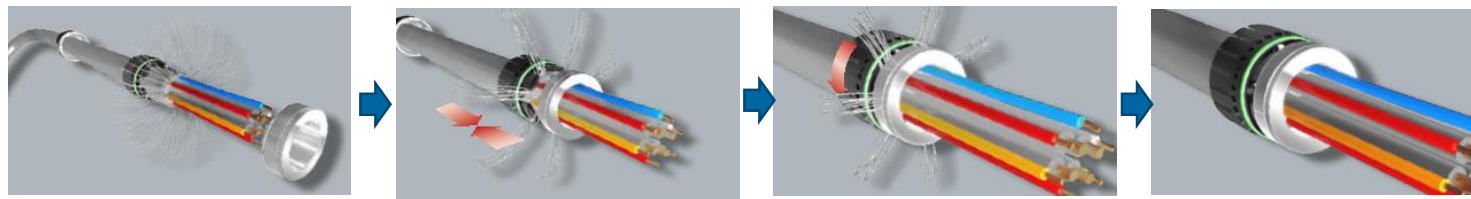

➤ Performance for EMI & High Speed

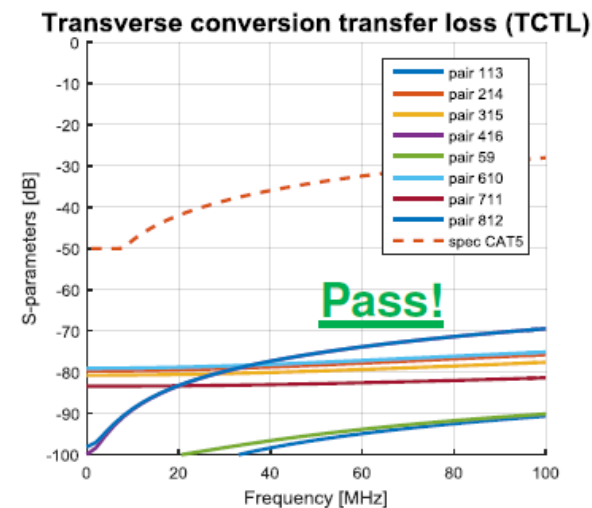
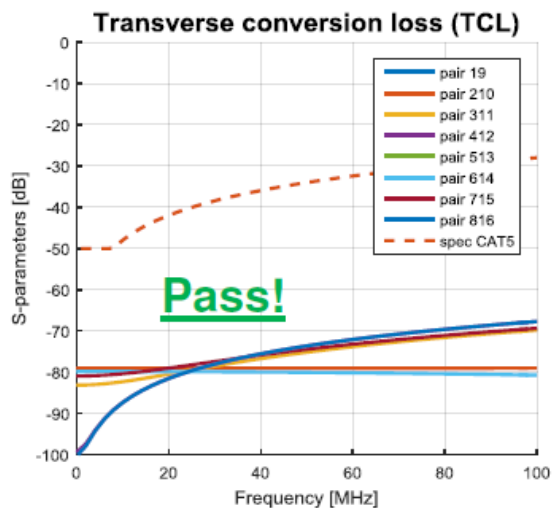
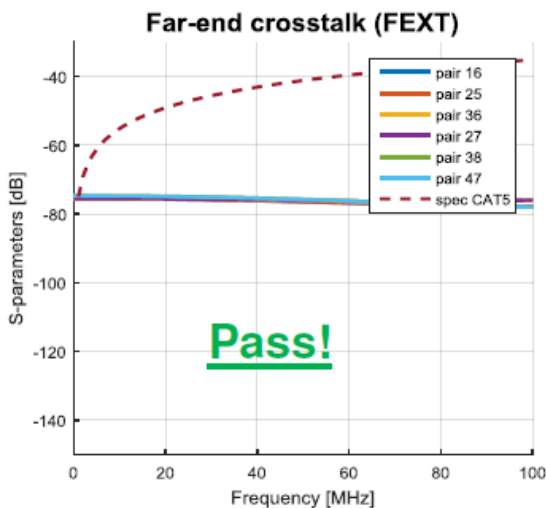
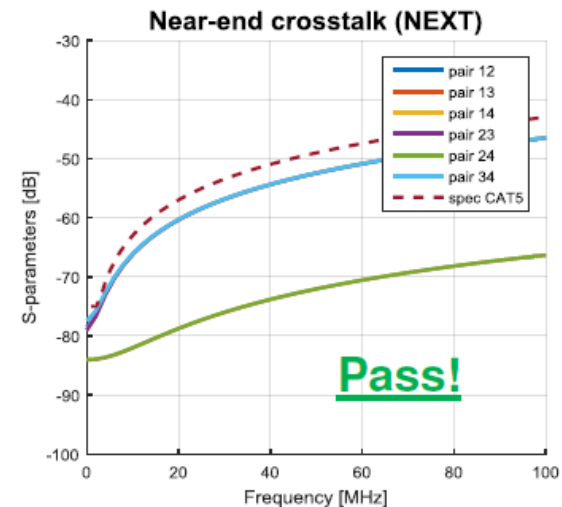
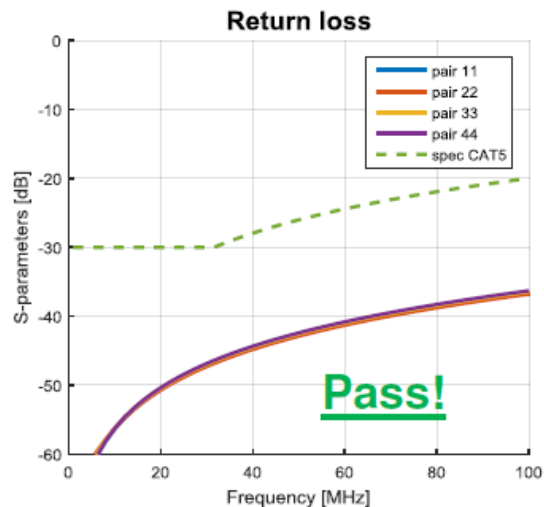
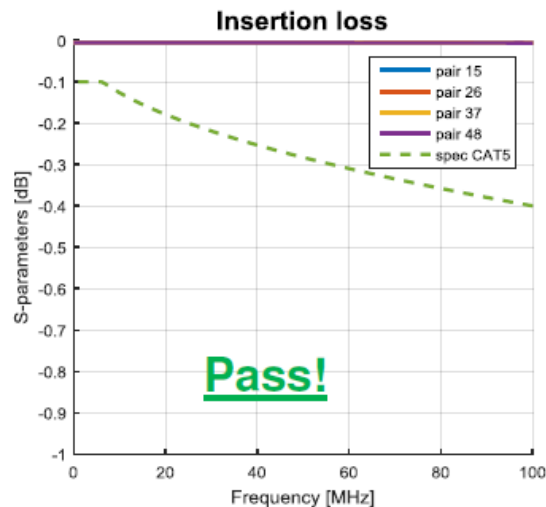

Trend: Reduction of installation costs

...the solution:

htec[®]

- Decentralized installation structures
- “Daisy chaining” of servo-drives
- **Significant reduction of cable lengths**

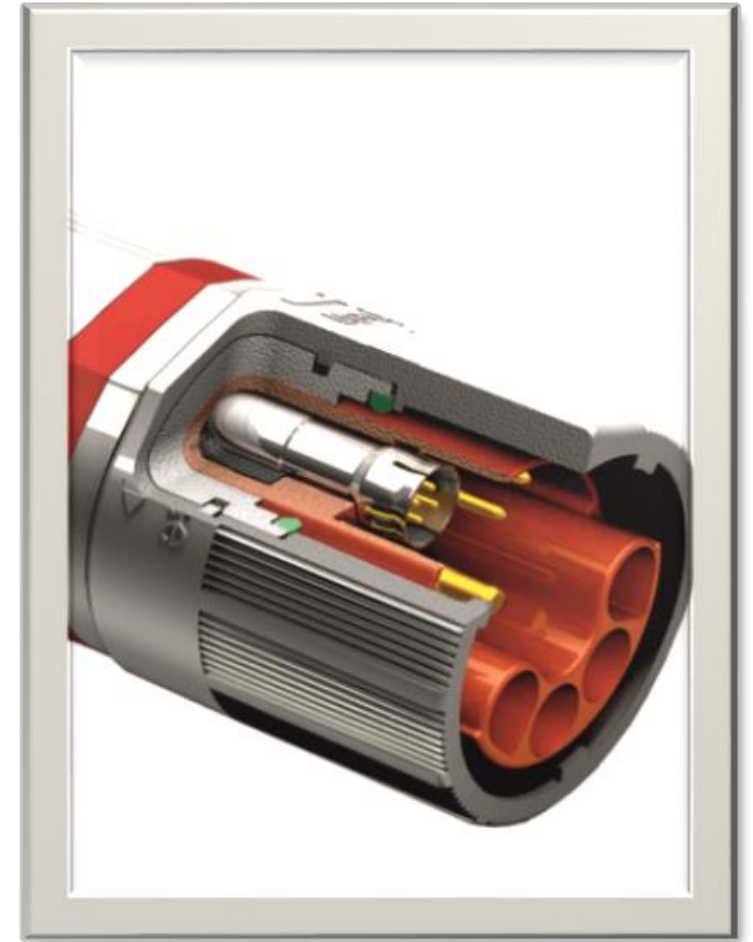

Trend: Reduction of installation times

...the solution:

Crown Clamp for shield termination

- Strain relief and integrated cable seal
- 360° shield termination without cutting the braid
- Secure locking of the cable

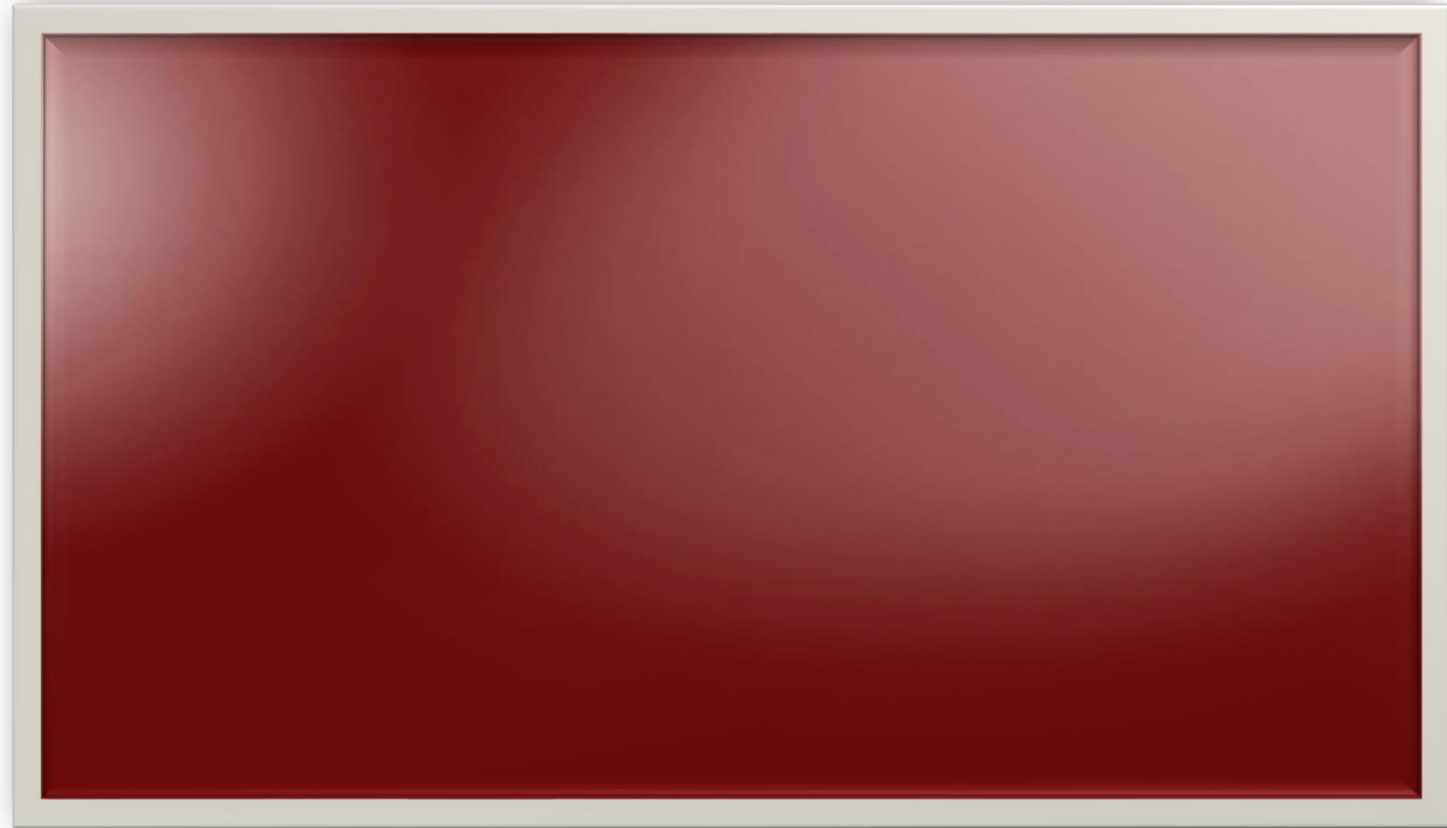

Trend: Reduction of installation times

...the solution:

Rotatable housing

- Cable direction can be chosen without special tools in a range of $\pm 115^\circ$
- One variant for all installations



Trend: Reduction of installation times

...the solution:

Insertion of contacts without tools

- Lateral insertion into the insulation body
- Positive locking



Trend: Reduction of installation times

...the solution:

Quick-locking system

speedtec[®]

Save
process cost with
speedtec

intercontec



The Configurator

....go to

www.intercontec.biz

www.intercontec.com

and select “Configurator”

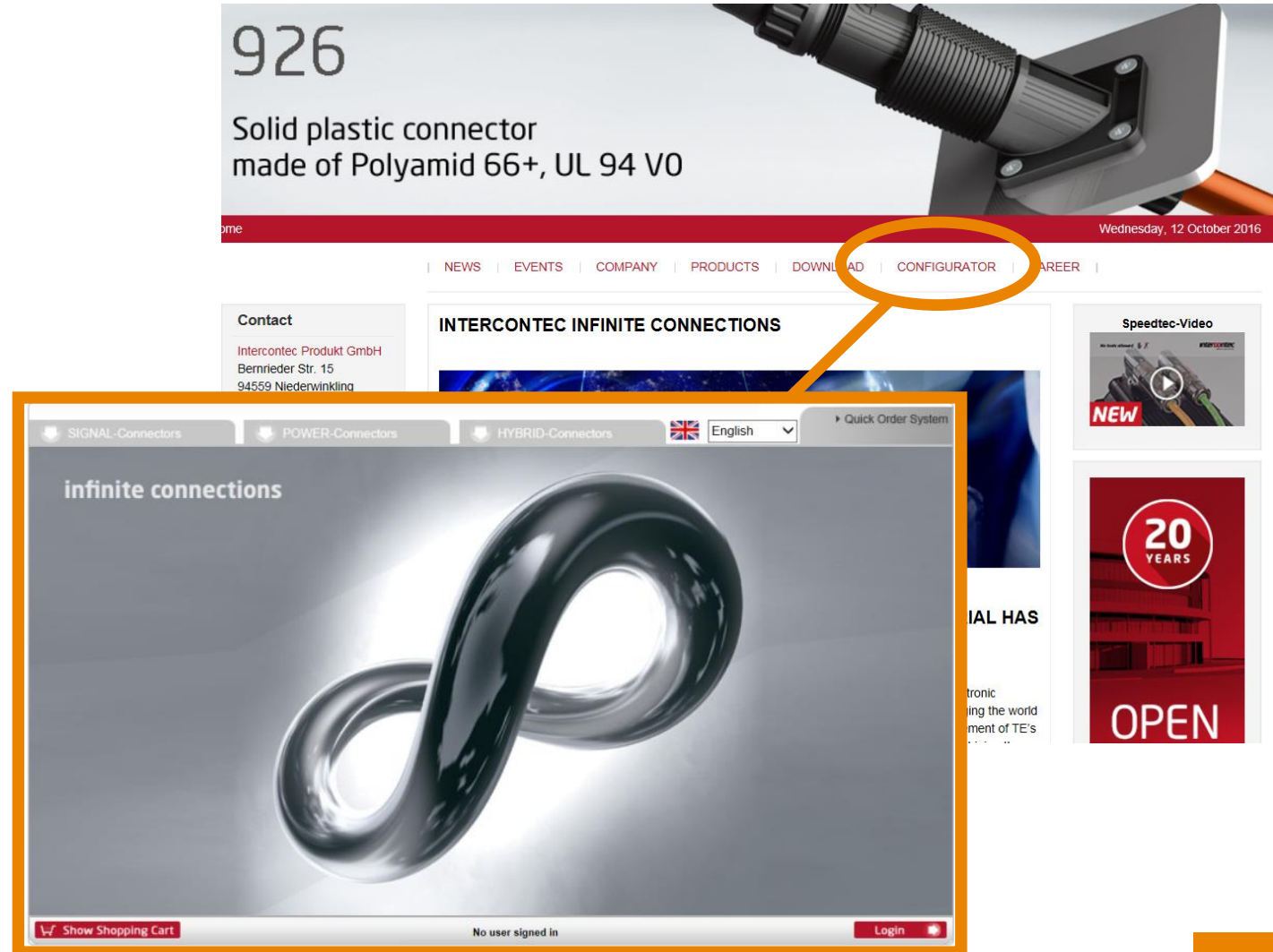

The image shows a screenshot of the Intercontec website. At the top, a navigation menu includes 'NEWS', 'EVENTS', 'COMPANY', 'PRODUCTS', 'DOWNLOAD', 'CONFIGURATOR', and 'CAREER'. The 'CONFIGURATOR' link is circled in orange. Below the navigation, there is a 'Contact' section for Intercontec Produkt GmbH. A large orange-bordered window displays the 'infinite connections' configurator interface, which includes a large infinity symbol, a language dropdown set to 'English', and a 'Quick Order System' link. At the bottom of this window, there are buttons for 'Show Shopping Cart', 'No user signed in', and 'Login'.

The Configurator

...the different housing styles can be selected...

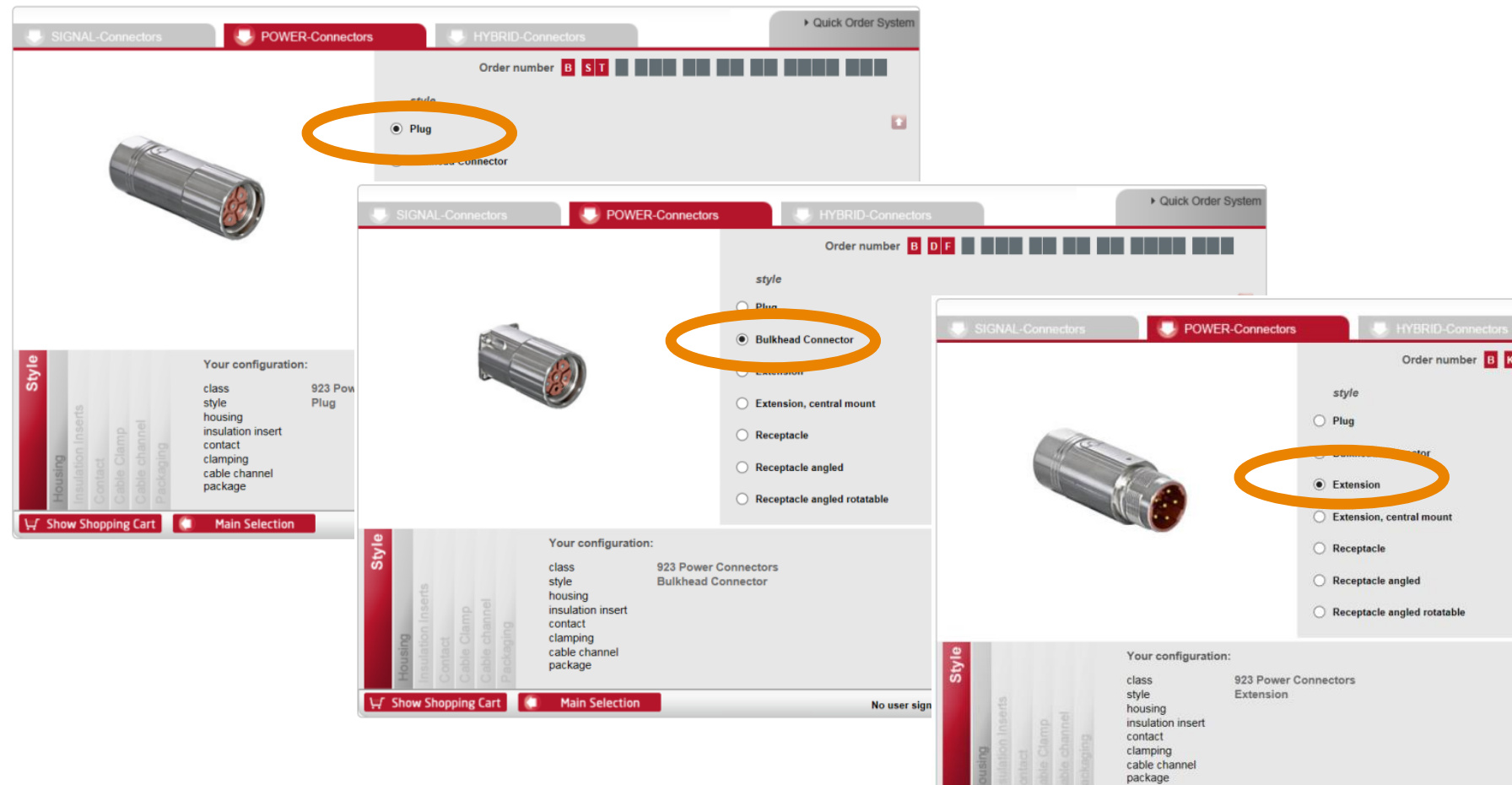

The Configurator

Data sheet generation

After finalizing the configuration, the **data sheet** button prompts to enter an e-mail address and....

Please insert your e-mail address.

OK Cancel Language

SIGNAL-Connectors POWER-Connectors HYBRID-Connectors Quick Order System

Your configuration Order number **B D F A 1 0 7 F R 2 3 0 0 0 1 5 0 0 0 0**

style insulation insert Distance bush contact clamping cable channel package

data sheet Lab report Assembly instructions

...the following documents will be provided instantly:

- **Data sheet** with all relevant technical and electrical data as well as drawings (mean measurements and flange mounting measurements)
- **Assembly instruction** with all details to assemble the connector as well a description of the needed tools

intercontec 923 Bulkhead connector

6-pin Earth-to-Housing Connection according to VDE 0627 Flange mount / Flange 25x25

B D F A 1 0 7 F R 2 3 0 0 0 1 5 0 0 0 0

Technical Data
 number of pins 6 (2+4E-2)
 color PL/S-L (nick./Ni-SN)
 temperature range -20 °C to 150 °C
 conduction type CRIMP

Electrical Data
 power 30 A
 rated current 630V (AC/DC)
 rated insulation voltage 6000 V

Material
 housing zinc diecast / nickel plated
 insulation insert PL/S-L (nick./Ni-SN)
 seals PBR
 contacts brass / gold plated

Contacts
 order code 60.021.11
 Contact Socket 2.0 mm
 crimp 2.30 - 4.00 mm
 contact resistance < 3 mΩ

Tools (not part of product contents)
 digital crimping tool for 2mm-2.5mm contacts order code: C3.236.00
 analog crimping tool for 1 mm-2 mm contacts order code: C3.231.00
 working force for crimp contacts order code: C3.204.00

QR code

Main Dimensions Bulkhead connector

*For max. wire cross-section, please refer to the cross-section of used contacts

intercontec MONTAGEANLEITUNG ASSEMBLY INSTRUCTIONS

923 Durchführung Spotlig. für Crimpkontakte 923 Bulk-Head Connector 6-pin, crimp version

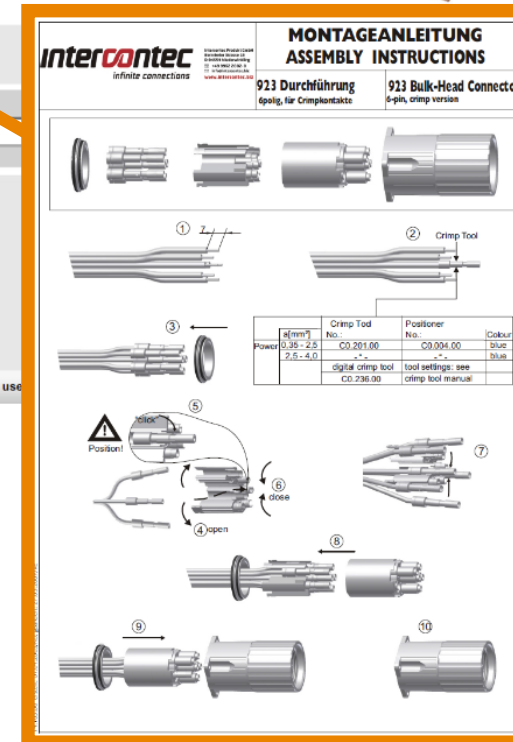

Power	Crimp Tool	Positioner	Colour
0.35 - 2.5	No. CO.201.00	No. CO.004.00	blue
2.5 - 4.0	digital crimp tool	tool settings: see	blue
	CO.236.00	crimp tool manual	

■ 효율적인 제어부 설계 기법



■ 나사방식 단자대라는 것은?

- ✓ 전기를 분배 시키는 것
- ✓ 보통은 세로 방향은 도통 시키며 가로 방향은 도통하지 않습니다.
- ✓ 그림과 같이 환형 압착 단자가 필요

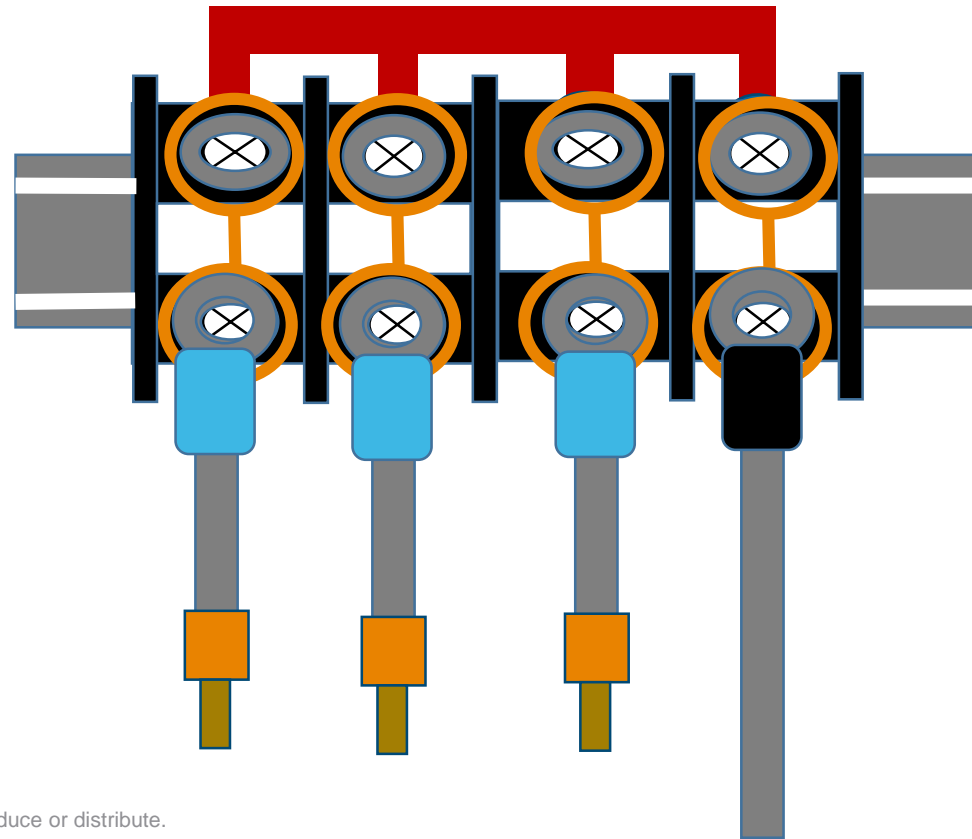

■ 유럽 스타일의 단자대

✓ 메리트 1. 공간 절약 가능

✓ 나사식

* 참고예

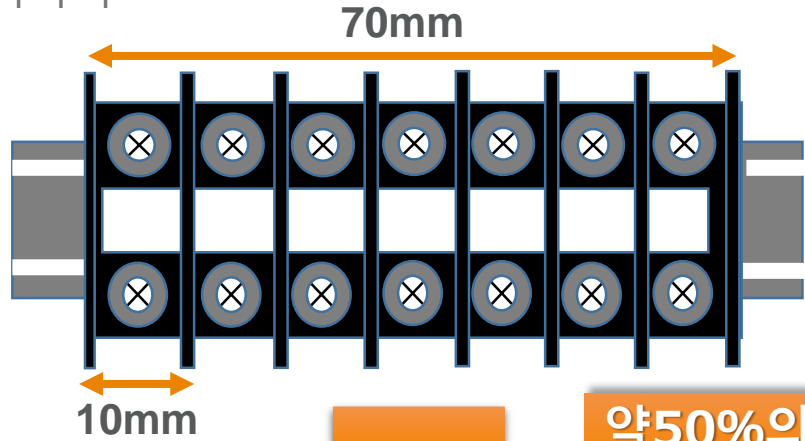

약50%의 공간
절약화를 실현!!

✓ Push식

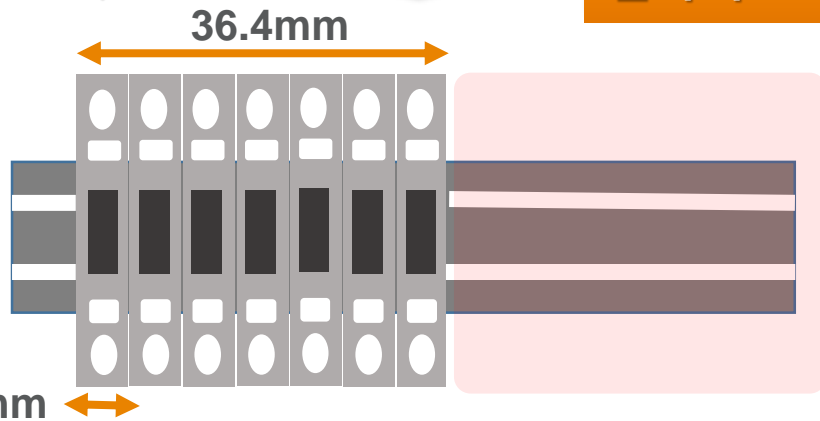

✓ 메리트 2. 공수절감

✓ 나사식

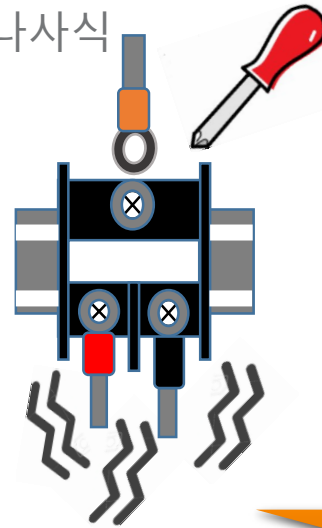

- ✓ 나사 조일때의 강도 관리 필요
(토크 관리, 풀림 방지등)
- ✓ 진동등에 의한 나사 풀림 위험

전선 피복 탈피 후
꽂아 넣는 것
만으로 완료!!

✓ Push식



- ✓ 원 액션의 삽입에 따른
공수 절감
- ✓ 진동등에 따른 풀림 또는
빠짐 없음

■ 국내 시장에 대한 유럽 스타일 단자대의 유의점

✓ 정말 공구 필요 없음??? → **페럴(Ferrules)** 단자를 필요하는 경우가 많음

✓ 페럴 단자의 **압착공수**가 발생해 버린다.



➤ Question : 왜 페럴 단자가 필요한가?

☞ 구미시장에서 사용되어지는 전선은 딱딱한 단선이 대부분

☞ 국내시장에서 사용되어 지는 전선은 유연한 연선이 대부분



국내시장에서는 페럴 단자가 필요한 경우가 많음

✓ 전선 삽입시에 클릭감이 없음 ☞ 전선을 당겨 보아서 확인해야함

✓ 환형 단자는 나사로 꼭 조이는 것으로 접촉 면적이 증가하여 발열되기 쉽지 않으나, Push in, Spring Cramp (Connector 포함)은 Contact의 접촉면적이 적은 이유로 나사 방식 보다 열이 발생할 경향이 있음



■ Entelec (엔트와랙) 이라는 것은 ?

TE 커넥티비티 (TE)는, 2018년8월, 스위스 · ABB사로 부터 Entelec 단자대 사업부를 인수하였습니다. TE는 이 사업부를 인수함으로써, 전원, 신호, 데이터 접속 분야에 대하여 , 특히 가혹한 환경속에서 목적에 맞는 총합적인 Solution을 제공할 수 있게 되었습니다.

Entelec (엔트와랙) 단자대에 대하여

1920년에 세워진 **DIN 레일 단자대** 개발 및 제조 사업부입니다.

70개국 이상의 나라에서 제품과 서비스를 제공하고 있습니다.

단자대의 연구, 개발을 행하며 현재 프랑스와 폴란드에 제조설비를 보유하고 있습니다.

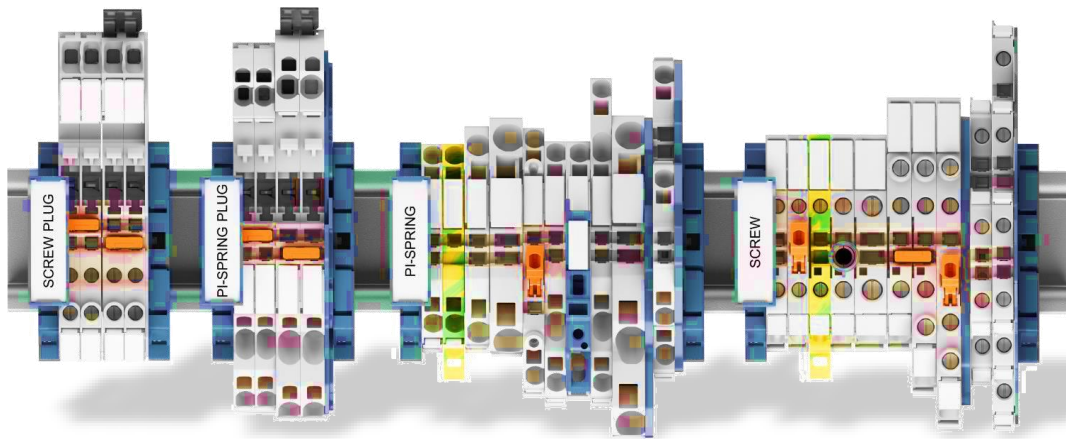

■ SNK 시리즈의 소개

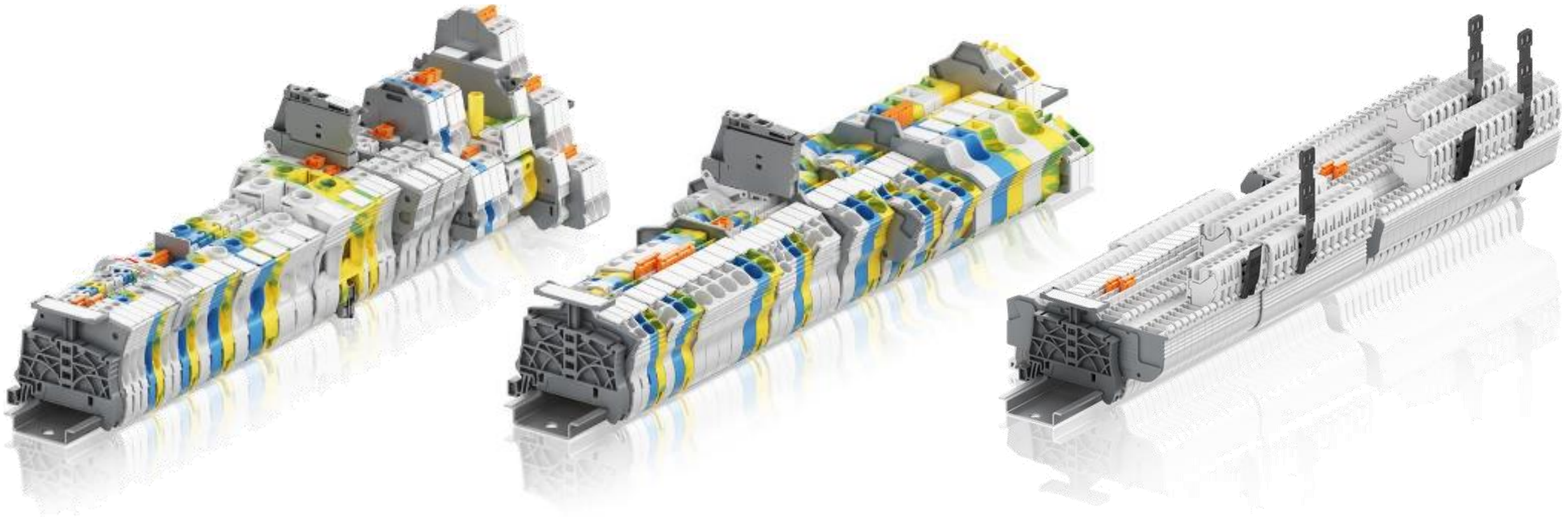

■ SNK 시리즈

➤ 다양한 결선 타입 & 적용 전선

✓ 적용전선 : **3 종류**

✓ 결선타입 : **4 종류**

Push in Type

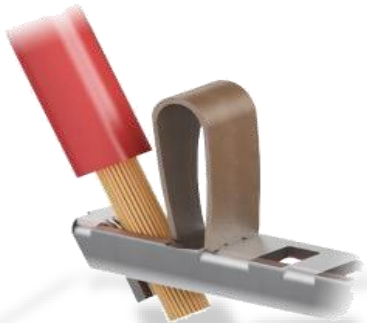

나사 타입

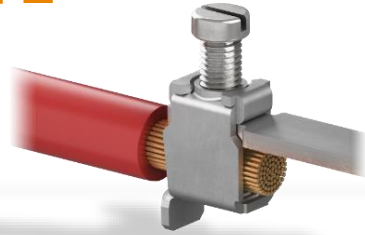

적용전선

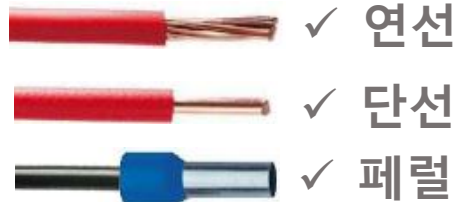

Spring Cramp

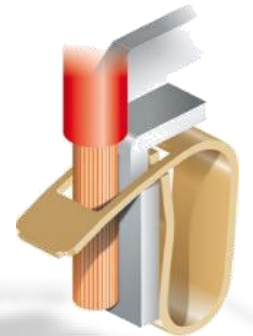

Pluggable

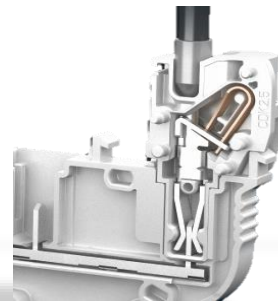

■ SNK 시리즈

➤ 사양 [개요] Push-in & Spring Cramp 시리즈

- ◆ 적용 전선 사이즈 : AWG26 – AWG4
- ◆ 전류치 : 20A – 76A
- ◆ 전압 : 1000V (IEC), 600V (UL-CSA)
- ◆ 보호등급 : IP20 (IEC), NEMA1(UL-CSA)
- ◆ Short Circuit Current Rating(SCCR) : 100kA
- ◆ 적용규격 :
- ◆ 하우징색 : 8색

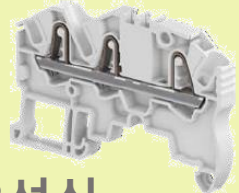

Color	
Grey	
Blue	
Orange	
Yellow	
Green	
Red	
White	
Black	



Grand

■ SNK 시리즈

➤ **특장** : Push-in & Spring Contact

✓ **최대의 특장** : 동일 제품에서 **Push-in & Spring Cramp** 가 가능 ! (특허취득)

2 in 1 connection

Push-in

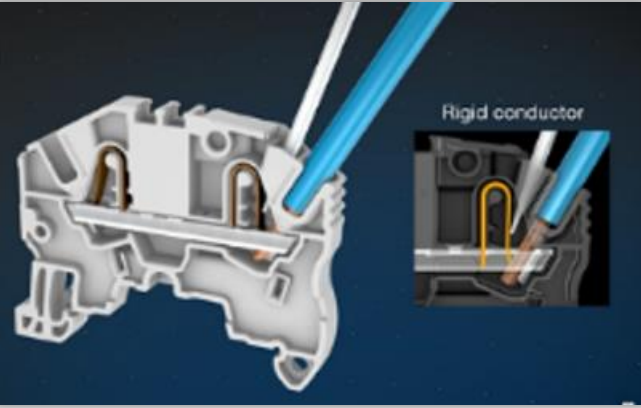

Spring Cramp

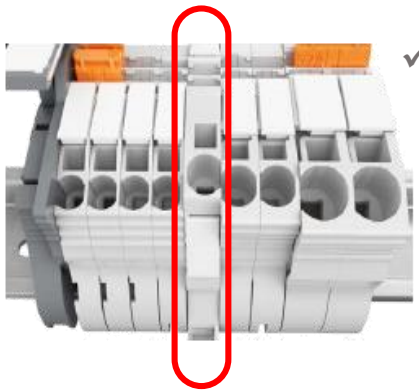
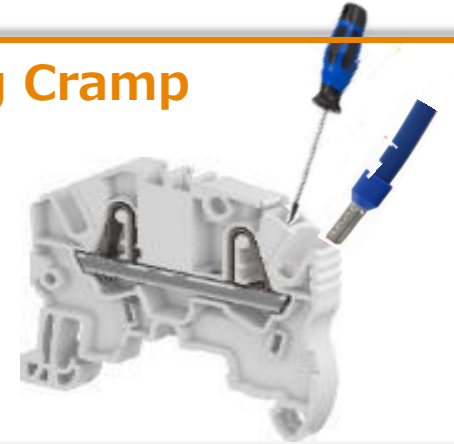

✓ DIN 레일 취부시
역삽방지



✓ 드라이버로
전압체크 가능
(Voltage test)

✓ 드라이버가 고정 가능하므로,
양쪽 손이 자유

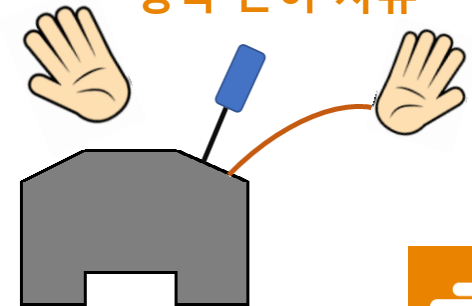

■ SNK 시리즈

➤ Pluggable type

✓ 특징①

플러그를 지닌 2피스 구조로 커넥터와 같은 탈착이 가능

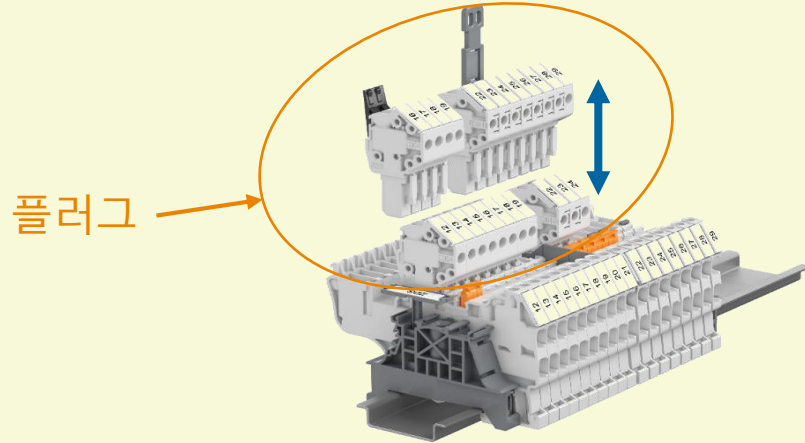

✓ 특징②

플러그의 연결이 가능하여 임의의 극수의 커넥터화가 가능



Lock Lever를 별도로 추가할 수 있는 구조

✓ 특징③

2접점 구조인 관계로 내진동성이 우수하다.

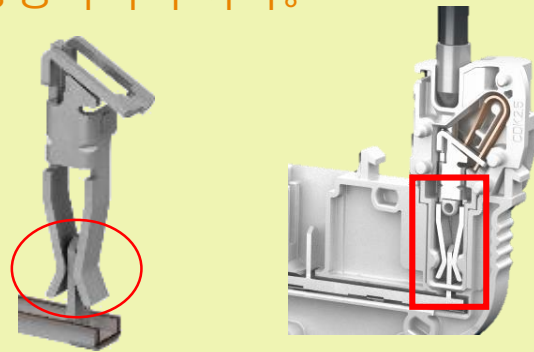

✓ 특징④

3 종류의 결선 방식의 조합

■ Pluggable-Pluggable

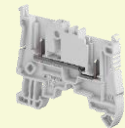

■ Push-in & Spring Cramp -Pluggable

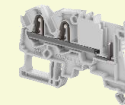

■ 나사방식 -Pluggable

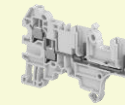

SNK 시리즈

악세서리류

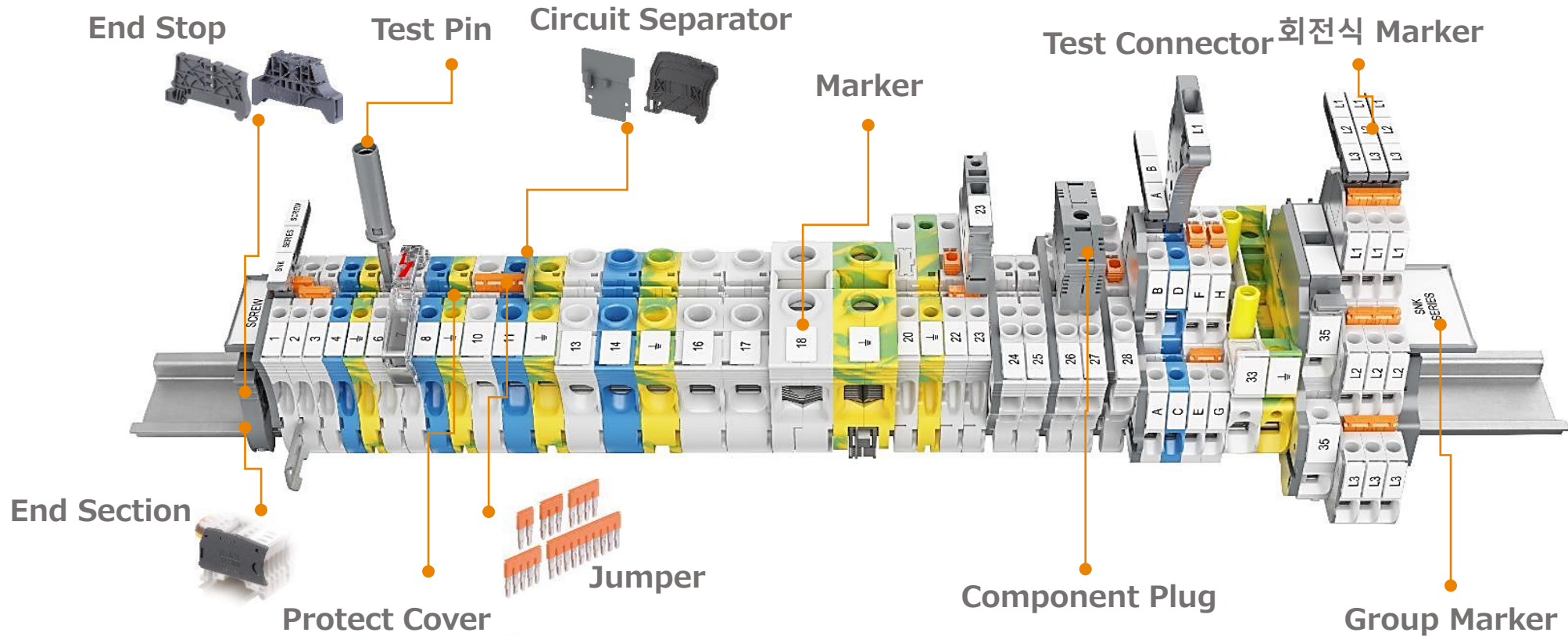

전용 마이너스 드라이버



페럴용 압착 공구

■ SNK 시리즈

➤ 페럴에 관하여

✓ Entelec 페럴용압착공구를 준비-페럴은 범용품이 적용 가능



Entelec 페럴 압착 공구
×
타사제 페럴



타사제 공구 × 타사제 페럴

- 페럴 단자 규격
* DIN46228-4
* UL486F

×

- 지정 치수 엄수

Entelec 단자대에
적용 [보증]

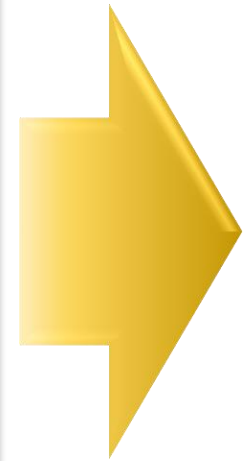
DBL 시리즈 DIN 레일 배전 블록

DBL POWER DISTRIBUTION BLOCKS



■ DBL 시리즈 DIN 레일 배전 블록

➤ DBL Distribution Blocks 시리즈란 ?

✓ 전원 라인을 복수로 분기시키거나 집약하는 것이 가능한 획기적 제품

Single Pole



Multi Pole



Grouping



넘기기 배선에 따른
다분기 출력

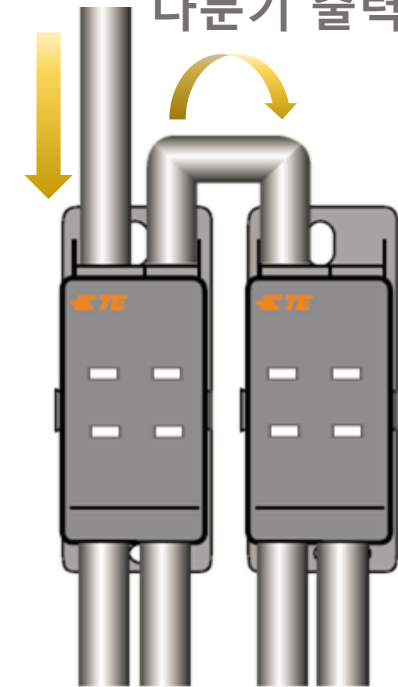

DBL 시리즈 DIN 레일 배전 블록

▶ 제품 사양 [개요]



- ◆ 정격전류치 : 80A~550A
- ◆ 정격전압치 : 1000VAC/1500VDC(IEC)
1000VAC/DC (UL)
- ◆ 적용전선 범위: AWG4~250Kcmil
- ◆ 결선방식 : 연선, 단선, 페럴 단자
- ◆ 취부방법 : DIN 레일, 패널 마운트 취부
- ◆ 대응 안전규격: IEC, UL, CSA, EAC, SCCR
- ◆ SCCR시험 : UL1059&UL508A에 따른SCCR 시험을
퓨즈와의 조합으로 100kA에서 Clear

결선부



Input : 육각 렌치
Output : +드라이버

***환형 단자 사용불가**

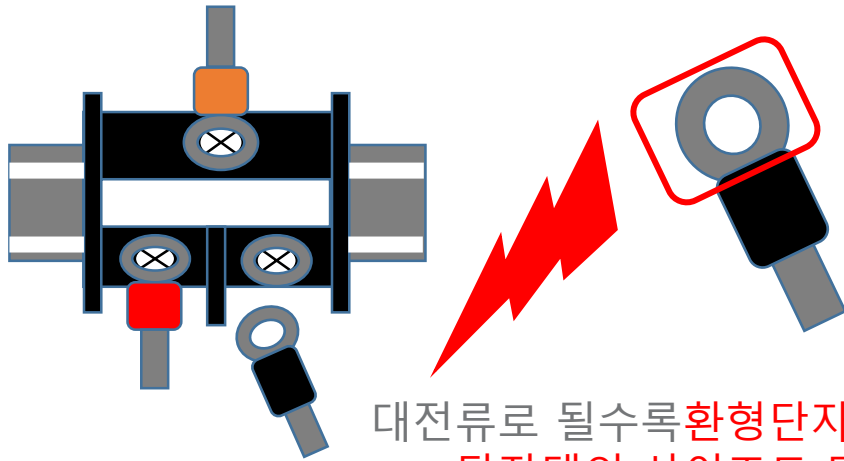

대전류로 될수록 환형 단자의 사이즈가 대형화 됨
☞ 단자대의 사이즈도 대형화

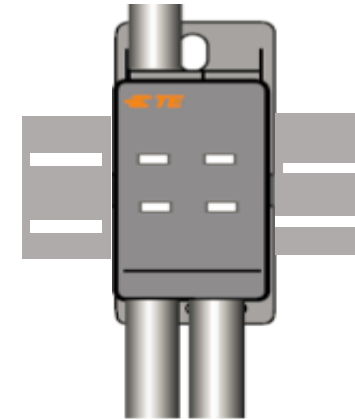

환형 단자 미사용
☞ 소형화 실현!

DBL Series DIN Rail Block

DBL Connecting Type [Wire Type]

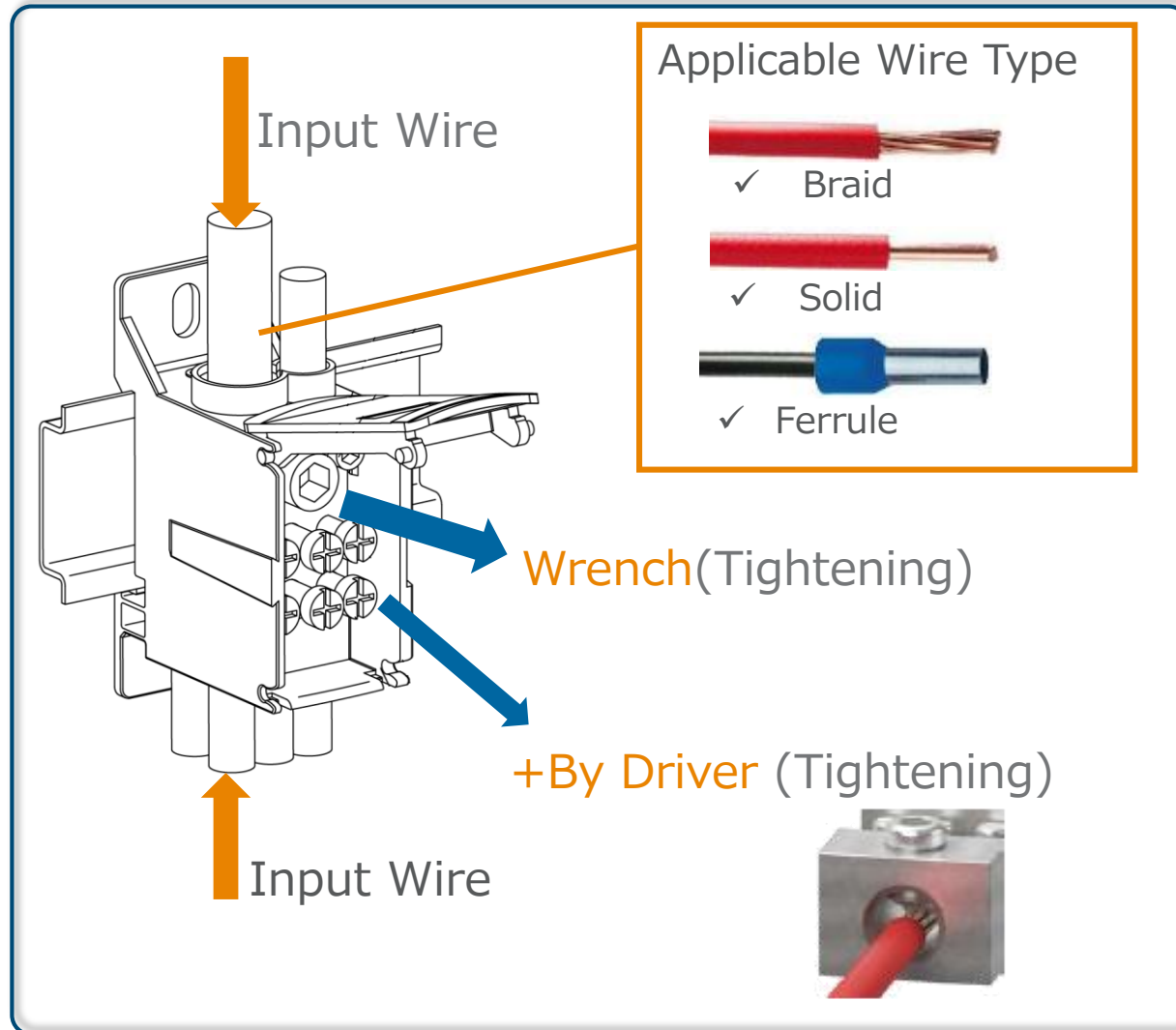

Input Wire

Applicable Wire Type

- ✓ Braid
- ✓ Solid
- ✓ Ferrule

Wrench (Tightening)

+By Driver (Tightening)

Input Wire

The diagram illustrates the wire connection process. An orange arrow labeled 'Input Wire' points to the top of the block. A blue arrow labeled 'Wrench (Tightening)' points to the terminal screws. Another blue arrow labeled '+By Driver (Tightening)' points to the bottom screws. A small inset shows a red wire being inserted into a terminal.

DBL Connecting Type [Bus Bar Type]

* DBL250-F, DBL500-F (곧 발매예정)

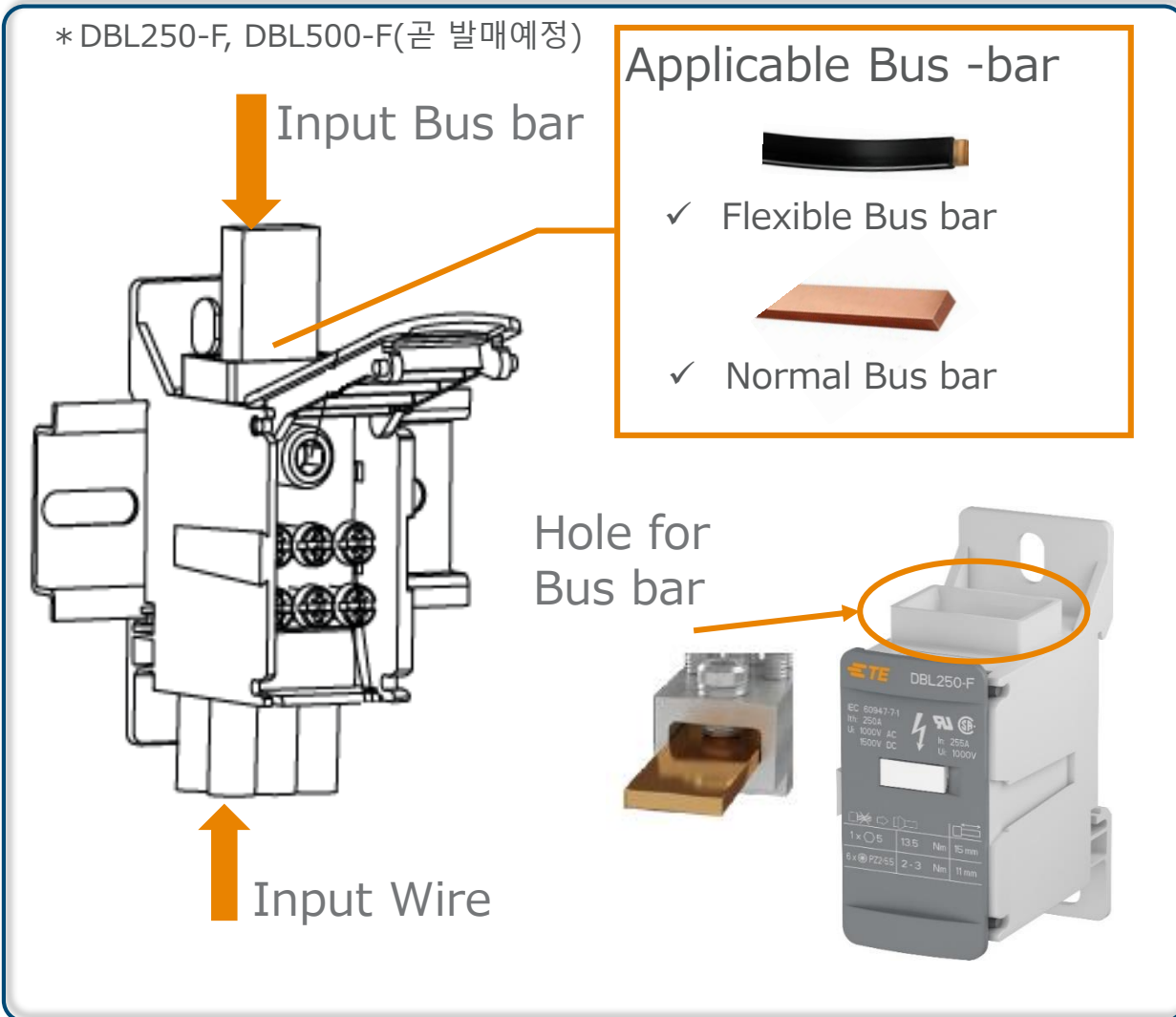

Input Bus bar

Applicable Bus -bar

- ✓ Flexible Bus bar
- ✓ Normal Bus bar

Hole for Bus bar

Input Wire

The diagram illustrates the bus bar connection process. An orange arrow labeled 'Input Bus bar' points to the top of the block. An orange arrow labeled 'Input Wire' points to the bottom. A callout shows a 'Hole for Bus bar' in the block. A photograph of a TE DBL250-F block is shown with a callout pointing to the bus bar hole.

DBL Series DIN Rail Block

Target Application & DBL Solution

Target Application



제어반



분전반



배전반

종례방식의 과제

Bus Bar에 의한 배전

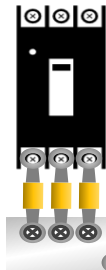

- ✓ 환형단자에서의 배선
- ✓ 특수 사양의 Bus bar
- ✓ 충전부의 노출

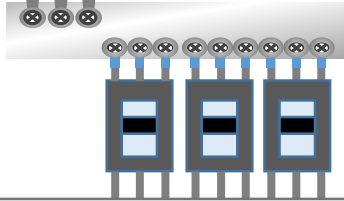

환형 분기 단자대에 의한 배전

- ✓ 환형단자에서의 배선
- ✓ 환형 단자대의 사이즈

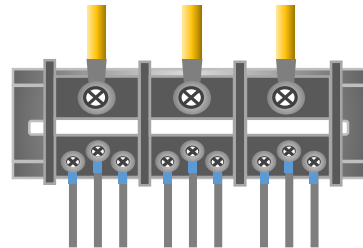

Entrelec DBL Solution

DBL로 실현 !

- ✓ 공간 절약화
- ✓ 환형단자 Bus bar 불필요
- ✓ 안전 대책

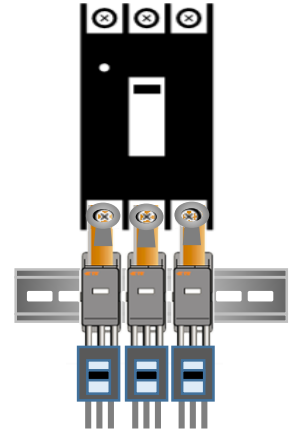

DBL로 실현 !

- ✓ 공간 절약화
- ✓ 환형단자 Bus bar 불필요
- ✓ 안전 대책

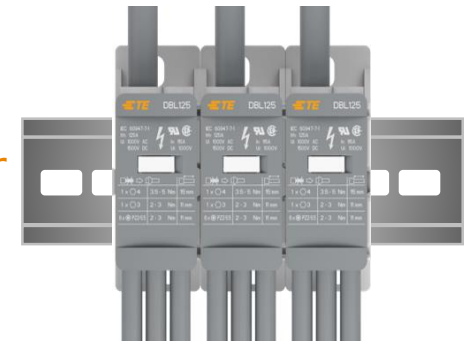

감사합니다.



TE 홍승모 부장 010-3392-5078
sm.hong@te.com