

스마트 모터 컨트롤 마우저 - 인피니언

이근형
2019년 10월 22일



Agenda

- 1 The world market for motors in appliances
- 2 VFD trends in MHA & SHA applications
- 3 Smart motor control solution
- 4 Design support

A world leader in semiconductor solutions



Our vision

We are the link between the real and the digital world.

Our values

We commit
We partner
We innovate
We perform

Our mission

We make life
easier, safer
and greener.

Part of your life. Part of tomorrow.

Agenda

1 The world market for motors in appliances

2 VFD trends in MHA & SHA applications

3 Smart motor control solution

4 Design support

The world market for motors in home appliances

The world market for electric motors in home appliances and residential HVAC applications – Unit shipments (thousands)

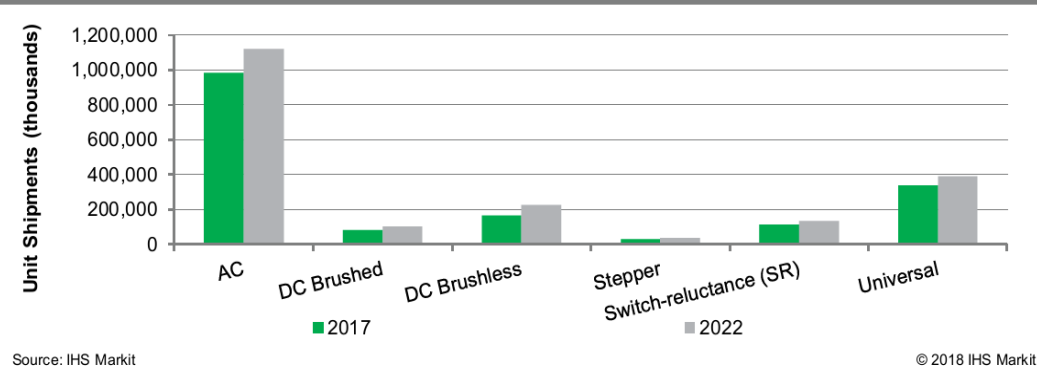

The world market for motor controls in home appliances and residential HVAC applications – Unit shipments (thousands)

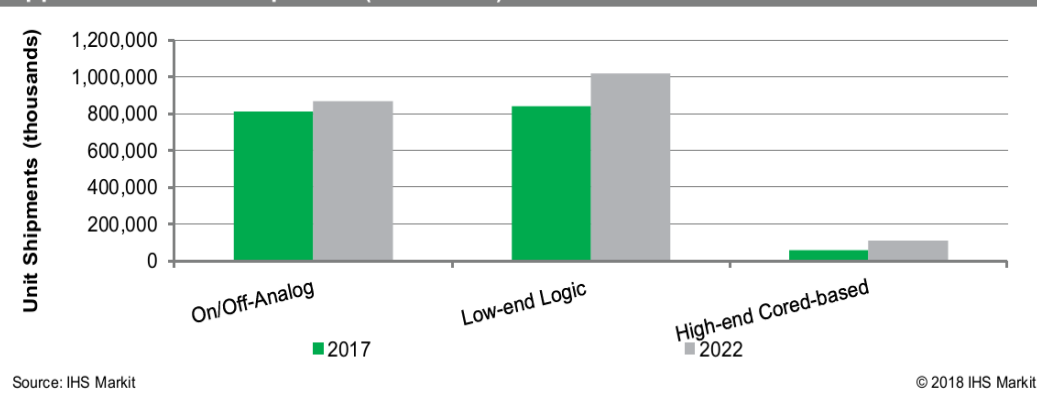

Motors in HA

- › The motors and motor controls in HA grew by 8.7%, with total revenues, USD 43.7B.
- › Unit shipments in 2017 were 5B, an increase of 7.6% from 2016 figures.
- › DC brushless motors are forecast to be the fastest growing.
- › High-end cored-based motor control is expected to have more shares leverage on high energy efficiency demand

AC motors

World market for AC motors in home appliances and residential HVAC applications – By unit shipments (thousand)

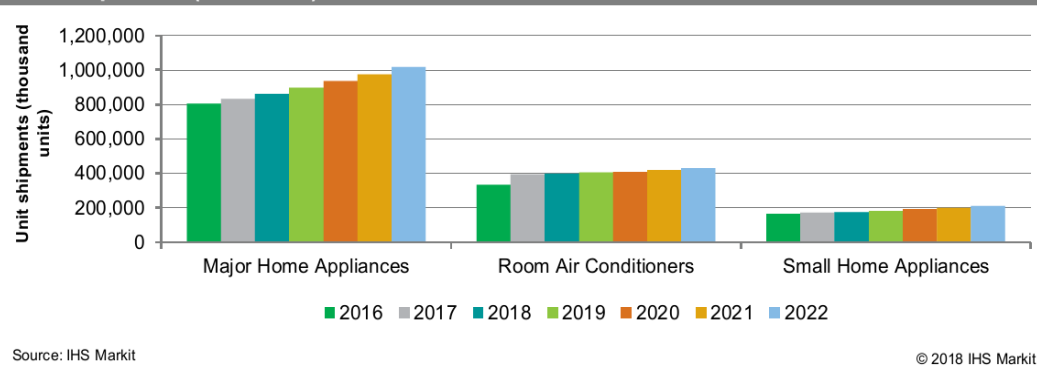

Market and trends

- > 1.4B AC motors shipped in Y2017 generating USD 7.4B in 2017.
- > Commonly used for dishwashers, refrigerators, and washing machines.
- > Clear transition from AC motors to DC brushless motors.

Semiconductor market

Despite a trend for greater variable speed usage in home appliances and residential HVAC application, slowing demand for AC motors

The vast majority of variable speed drives in this home appliances and residential HVAC applications segment are three-phase drives.

Typically a DSP or microcontroller. Depending on the level of control, a feedback signal providing information about the motor position may also be required to close the loop.

DC brushed motor

World market for DC brushed motor in home appliances and residential HVAC applications – By unit shipments (thousand)

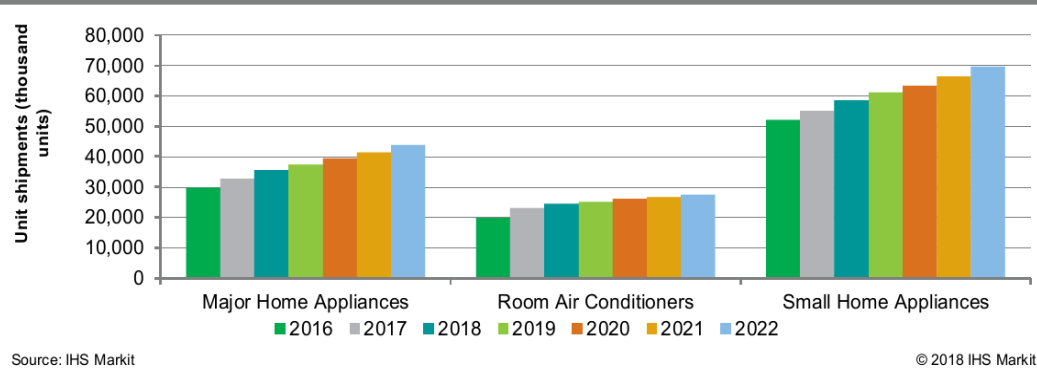

Market and trends

- > The global DC brushed motor unit shipment into the HA applications were about 0.1B in 2017.
- > Limited use for the low cost market suitable for price sensitive.
- > More than 50% of DC brushed motor were shipped for the use of SHA applications.

Semiconductor market

DC brushed motor represent the most cost-effective motor solution on the market and preferable option for small home appliance applications. Nearly 80% of DC brushed applications operate at a fixed speed.

Variable resistor and silicon controlled rectifier (SCR) for speed adjustment will be required for DC brushed motor control for appliances with AC input.

Minimal impact towards the semiconductor component demand because the semiconductor contents is limited.

DC brushless motor

World market for DC brushless motors in home appliances and residential HVAC applications – By unit shipments (thousand)

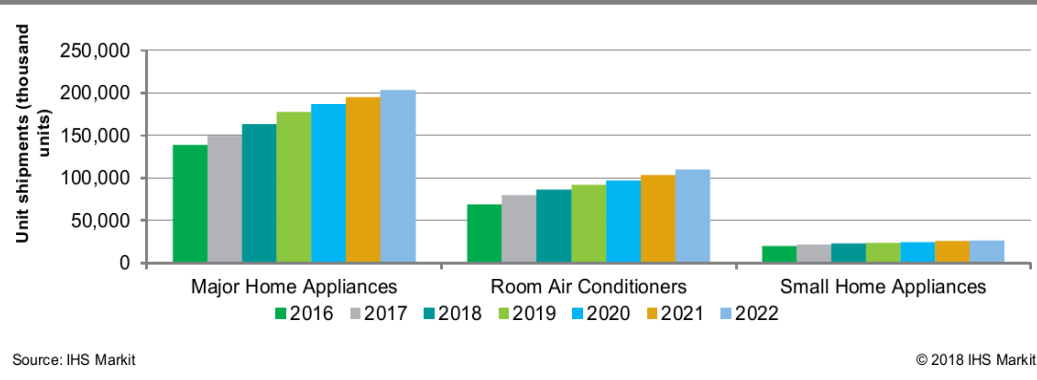

Semiconductor market

Unlike DC brushed motors, DC brushless motors cannot be driven directly from a power source, and require some form of electronic commutation to generate torque. The growth of DC brushless motors in home appliances applications creates opportunity for semiconductors.

BLDC motors tend to utilize a hall sensor for positional feedback, although it is possible to perform measurements on the back EMF to deduce rotor position. This latter control approach is often termed sensor-less control, since the Hall effect sensor is not used; however, the positional sensor is replaced with a current sensor to provide the back EMF measurements. Sensor-less control may be less expensive to implement, but it provides less sophisticated torque control of the motor, particularly at lower speeds.

Market and trends

- › BLDC motor in HA is predicted to grow by 11.3% from 2016 to 2017.
- › An increase in the penetration of BLDC motors in HA.
- › The growth of DC brushless motors in home appliances applications creates opportunity for semiconductors

Stepper motor

World market for stepper motors in home appliances and residential HVAC applications – By unit shipments (thousand)

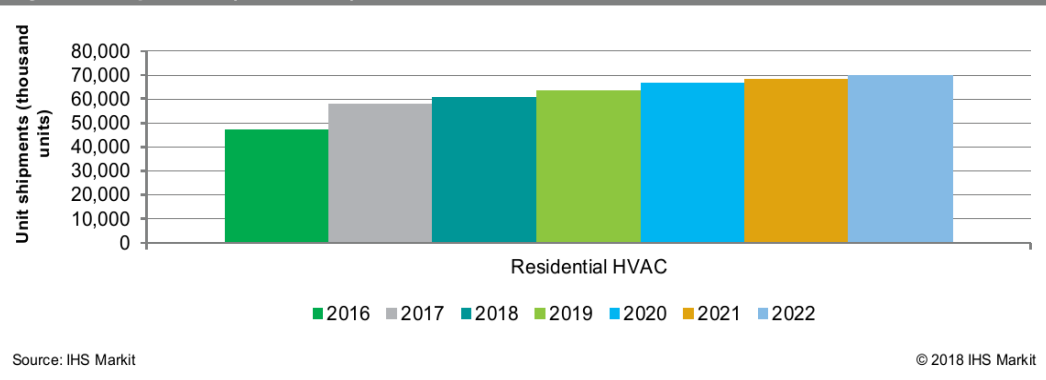

Semiconductor market

Stepper motor in residential HVAC typically controller by low-end MCU, DSP, or a similarly-designed logic circuit. In certain residential HVAC product which is more cost-sensitive, there is a little need for a 32-bit MCU just to control the louver positioning motors and it is not predicted that any high-end core-based control logic will be implemented in this market segment. However, in applications with higher-end technology such as smart air-conditioning system, MCUs in stepper drives are moving slowly to high-end core based controllers in order to support smarter and more complex feature such as configurable position controllers to control position ranges and parameters.

Market and trends

- > Stepper motors in residential HVAC is about 0.6B unit shipment in 2018.
- > Asia Pacific (including Japan) was the largest regional markets, with an estimated 55% share.
- > The market trend is closely tied to ductless room air-conditioner demand.
- > Controlled by MCU, DSP or logic circuit.

SR (Switched-reluctance) motor

World market for SR motors in home appliances and residential HVAC applications – By unit shipments (thousand)

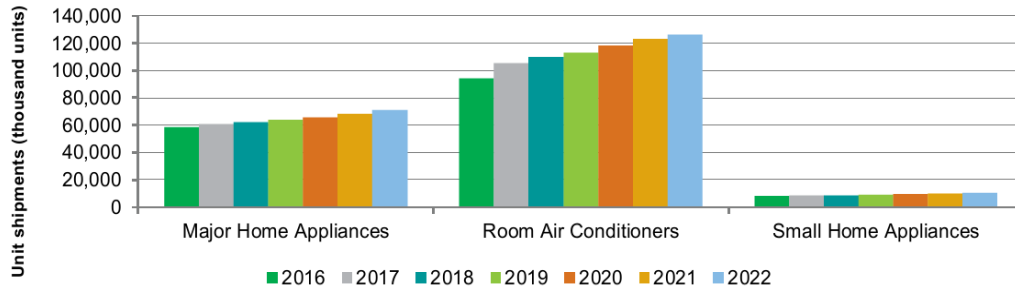

Source: IHS Markit

© 2018 IHS Markit

Semiconductor market

SR motors are gaining wider popularity among variable speed drives due to lower construction cost, which is characterized by an absence of magnets and rotor winding. The significant price drop of semiconductor as compared to a decade ago is driving the penetration of SR motors and drives in the home appliances segment. For numerous applications such as vacuum cleaners, availability and a moderate cost of the necessary electronic components has made SR drives a viable alternative to other commonly used motors like AC, DC brushless or universal motors. The majority of applications that adopt this motor type are likely to incorporate a power supply, and therefore use of this motor type will drive demand for rectifiers, particularly in small household appliances such as vacuum cleaners.

Market and trends

- › SR motors had the highest ASP in 2018. So the prices of SR motors are forecast to decline further than any other electric motors.
- › Simple construction, robustness and the ability to operate at high temperatures.
- › Can be found in front-load washing machines, blenders, vacuum cleaners.

Universal motor

World market for universal motors in home appliances and residential HVAC applications – By unit shipments (thousand)

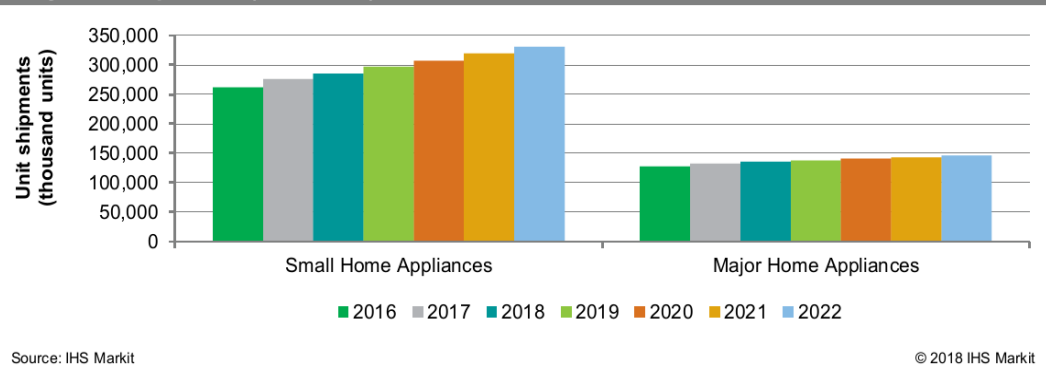

Semiconductor market

The opportunity for semiconductors used in universal motor control is very limited. Since other motor types offer better speed control, are less acoustically noisy and provide better reliability over time, any design choice to adopt a universal motor is made purely from a cost standpoint. As such, only rudimentary speed control is likely to be implemented, otherwise a different motor technology would likely be used. The largest volumes of these devices are found in the least expensive appliances like food processors and blenders targeted at the most price sensitive consumer markets

Market and trends

- › 0.4B units of universal motors shipped for home appliances.
- › Forecast to grow at the market average with a shipment CAGR of 3.1% from 2017 to 2022 as a result of increased competition from DC motors.
- › Targeted at the most price sensitive consumer markets.

Agenda

1 The world market for motors in appliances

2 VFD trends in MHA & SHA applications

3 Smart motor control solution

4 Design support

Inverter-based motor drive improves power efficiency

Fixed-speed drive

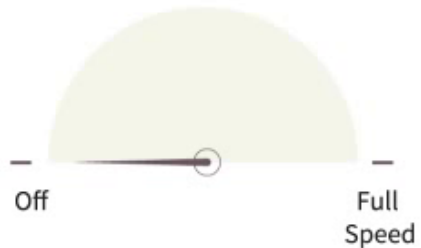

Non-Inverter

- Constantly turns on and off
- Wastes energy
- Creates excessive noise

**Higher
Energy
Efficiency**

Variable-speed drive

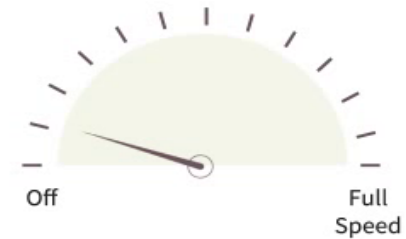

Inverter

- Changes its speed as need be
- Enables precise control
- Reduces energy consumption (up to 40%) and noise

Inverterization is driving the global demand for power semiconductors

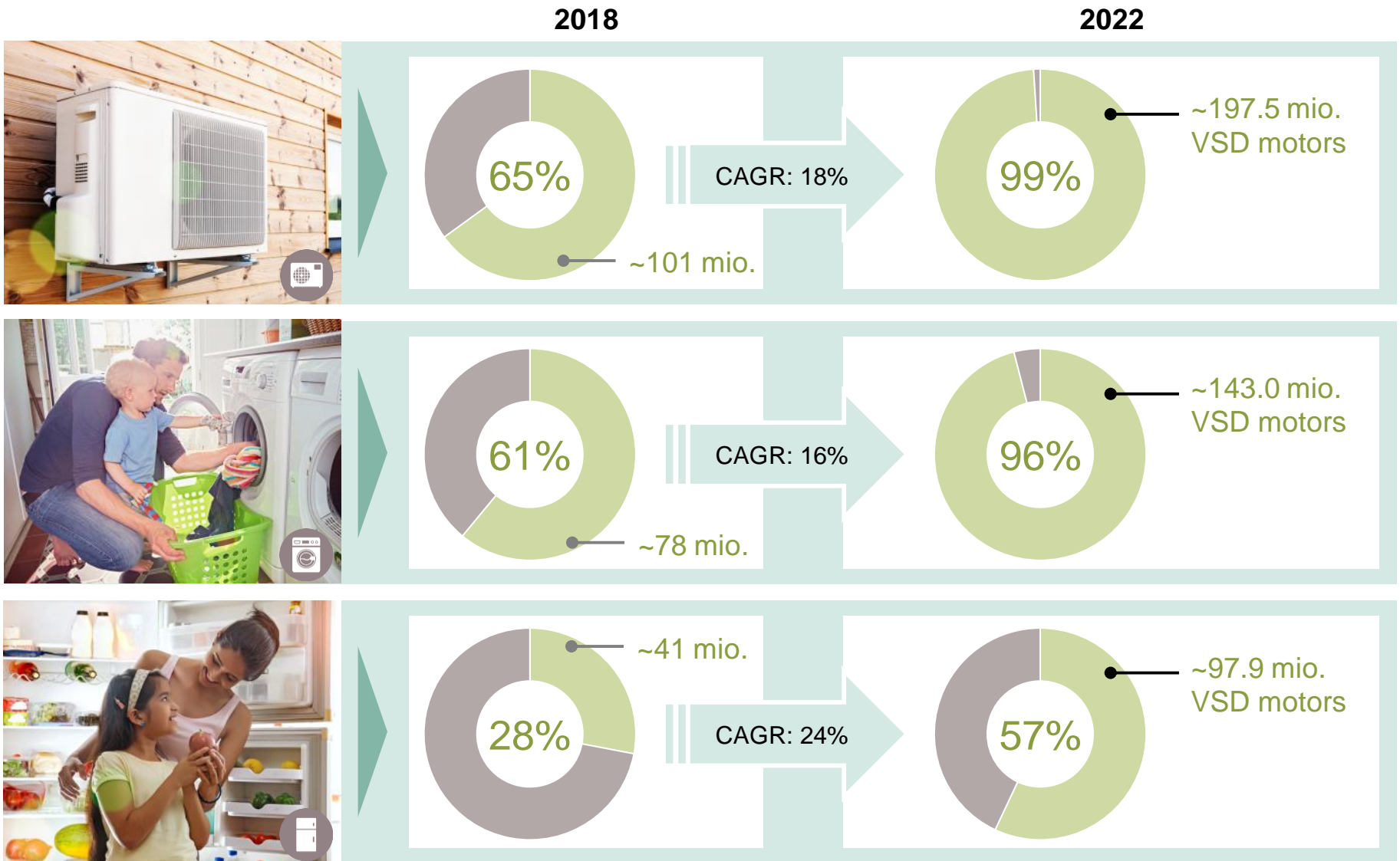

Note: Based on or includes content supplied by IHS Markit, Technology Group, "Home Appliance Database: All Devices & Associated Electronics", May 2018

How big is the total market and is it growing? SHA motor applications classified by IHS



Worldwide total motor shipments - SHA Unit Shipment ('000)

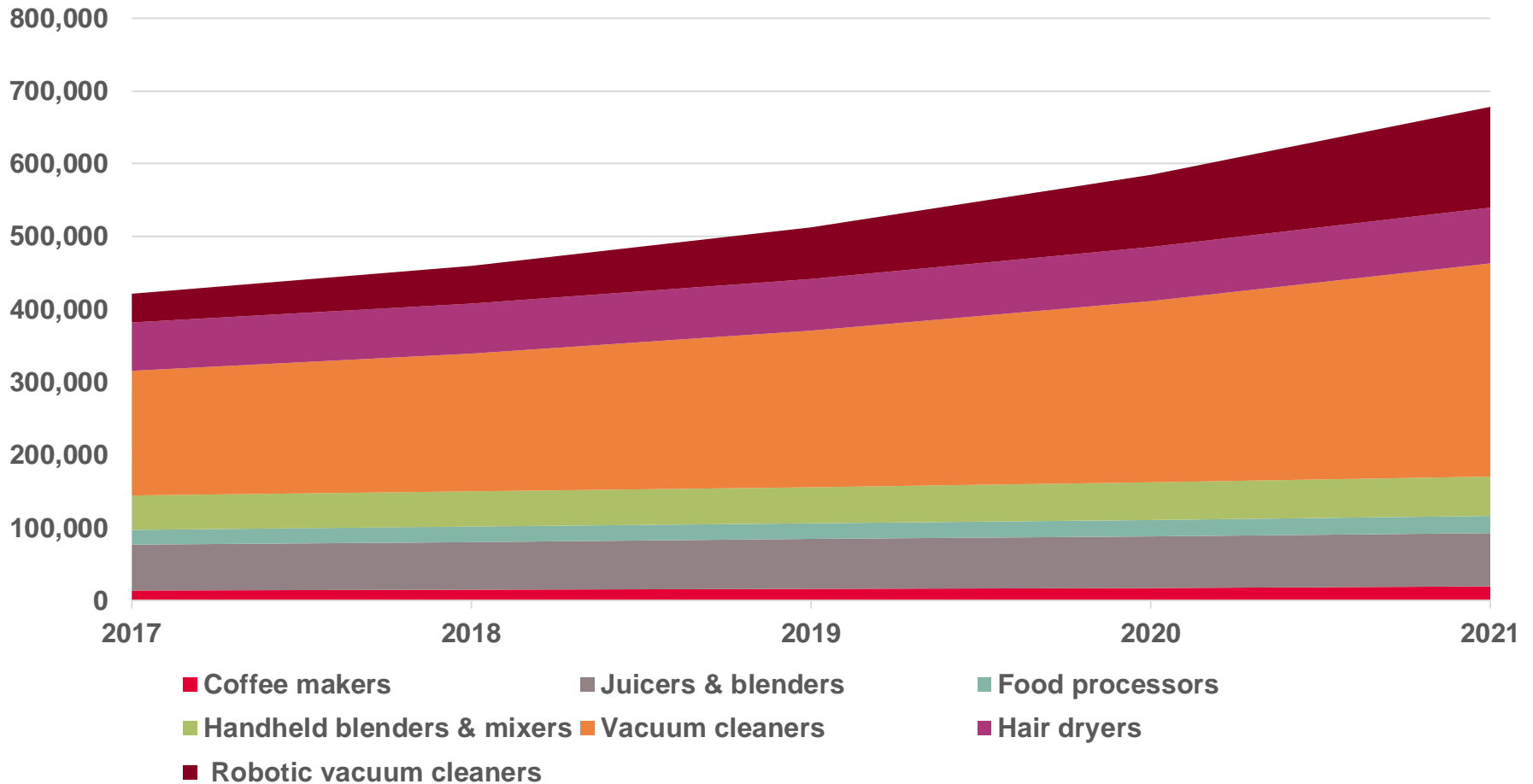

Source: IHS Jan 2019

BLDC blender

BLDC blender



- > **More durable**
 - > Without brush / commutator erosion.
 - > More extensive life expectancy and maintenance-free experience.
- > **Quieter**
 - > Without mechanical friction inside the motor.
 - > Noise is dramatically reduced.
- > **More Efficient**
 - > A higher energy efficiency than the conventional universal motors.
 - > Reduces energy consumption by up to 40%.
- > **More Powerful**
 - > Able to work at a desired constant high speed.
 - > Ensures a powerful performance from the start to the end.
- > **More Versatile**
 - > Works produces wider speed range and bigger torque.
 - > Any blending, crushing, or grinding tasks are all a breeze.
- > **Longer Continuous Work Time**
 - > Lower temperature rise so it allows for continuous work.
- > **More Safe**
 - > There is no sparking as there is no commutator and brushes.
 - > Supported by the housing, so they can be cooled by conduction.
 - > Entirely enclosed and protected from dirt or any foreign subjects

BLDC hair dryer

BLDC hair dryer



- > Powerful airflow
- > Smart heat control: REAL cool mode
- > More durable life time
- > Reasonable market price, USD 40 ~

How big is the total market and is it growing? More than IHS SHA classifications

Ceiling fan



Water purifier



Air circulator



Residential boiler



Dehumidifier



Desert cooler



Food waste disposer



Air purifier



Ceiling fan

India ceiling fan market size
Unit shipment ('000)

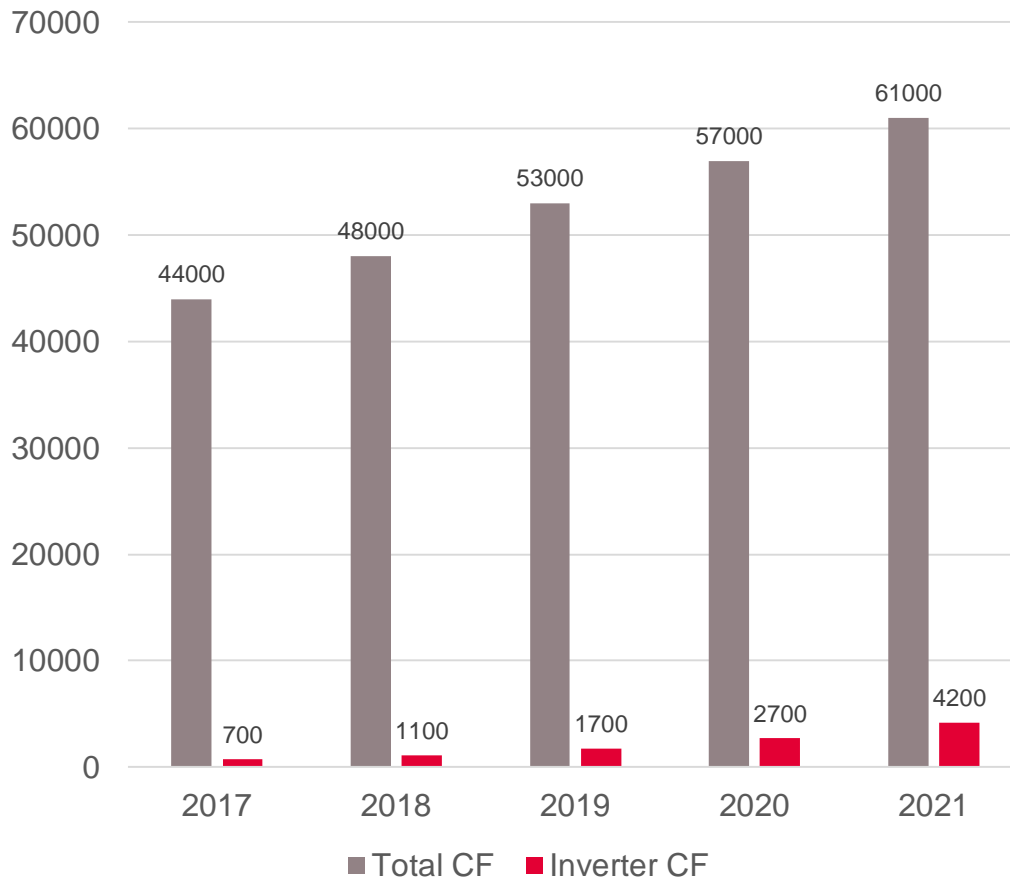

Source: IFA, Ministry of Power, India, CEAMA, Primary Respondents

India ceiling fan

- > The penetration of inverter ceiling fans was 1.8% in 2017; and the penetration is expected to increase to 6.9% by 2021.
- > Mainly low voltage BLDC motors are used for inverter ceiling fans. LV motor share is about 80%.
- > Infineon offering scope is motor controller, gate driver IC, power semiconductor, SMPS IC.
- > Local major players, Orient, Crompton, Havells, Bajaj have 70% shares. LG is also jumping into the market with premium models, smart ceiling fans.

Water purifier, air circulator & fan

Water purifier



- > No water tank; no bacterial propagation
- > Slim design
- > Cold water by inverterized compressor
- > Hot water by induction heating

Air circulator & fan



- > More and more BLDC motor for fans
- > Lower acoustic noise without mechanical friction
- > More energy efficient
- > More powerful at a high speed

Customer products & their trends

LG Smart Ceiling Fans - India's First Ceiling Fan With Dual Wing...

<https://www.lg.com> > ... > Home Appliances > Fans
Complement your home décor with all new premium range of **LG Ceiling Fans** in India featuring Dual Wings that delivers the best airflow with low turbulence ...



Usha Desert Air Coolers - Powerful Air flow & Multiple Capacity

<https://www.ushaaircoolers.com/desert-coolers>
2019. 3. 30. - USHA provides air **desert coolers** with wide range of tank capacity suitable for cooling large spaces. Check complete range of our **Desert Coolers** online.



해피콜, 프리미엄 블렌더 '액슬림S' 출시
매일경제 - 2019. 4. 17.
해피콜의 초고속 블렌더 라인업 최초로 **BLDC 모터(Brushless Direct Current motor)**를 탑재한 것도 강점이다. 일반 모터는 내부에 탄소성유로 된 ...
해피콜, 플래그십 초고속 블렌더 '액슬림S' 출시
이투데이 - 2019. 4. 17.

액슬림 시리즈의 최신이자 최고급 모델인 '액슬림S(모델명 BL7000)'는 기존 액슬림Z보다 더욱 강력하면서도 소음을 획기적으로 줄였다. 해피콜의 초고속 블렌더 라인업 최초로 **BLDC 모터(Brushless Direct Current motor)**를 탑재한 것도 강점이다. 일반 모터는 내부에 탄소성유로 된 브러시가 있어 모터를 사용할수록 이 부분이 마모된다. 브러시가 없는 BLDC 모터는 일반 모터 대비 내구성 우수해 고속 회전에도 큰 지장이 없고, 소음과 열 발생이 적어 항공가드론-에어컨 등 정밀 기기에 주로 사용돼 왔다.

Meet the new revolutionary LG Puricare Tankless water purifier

AUGUST 14, 2019 LIVING
BY STAR2.COM
PHOTOS BY LG ELECTRONICS MALAYSIA

In bringing the latest technology trend from South Korea, leading home appliances manufacturer LG Electronics Malaysia (LG) recently launched its PuriCare Tankless water purifier, providing Malaysians with healthy and easy access to clean drinking water at home.

Thanks to LG's innovative **Inverter Compressor and Induction Heating (IH) system**, the PuriCare Tankless water purifier can instantly offer hygienic drinking water – hot, cold, or room temperature – while consuming less energy.



Food waste disposer

스마트카라, 홍콩국제전자박람회2018 참가... 글로벌 시장 공략 나서
국민일보 - 2018. 10. 10.
친환경 음식물처리기 브랜드 스마트카라(대표 배성우)가 10월 13일부터 10 ... 또한 **메인 모터와 배기 FAN에 BLDC모터를 적용하여 내구성을 향상**...

친환경 음식물처리기 브랜드 스마트카라(대표 배성우)가 10월 13일부터 10월 16일까지 홍콩중합전시장에서 개최되는 세계 최대 규모의 전자제품 박람회인 제 38회 '홍콩국제전자박람회2018(HKEF2018)'에 참가한다.

여기에 5L 대용량 친환경 음식물처리기 '이노베이션(PCS-500)'의 경우 처리된 음식물을 보관할 수 있는 스마트 보관함을 도입해 처리된 음식물을 한번에 모아 버릴 수 있게 했다. 처리 용량을 5L로 늘려 처리 후 결과를 배출 횟수도 월 1~2회면 충분하다. 기존의 스마트보관 기능과 더불어 한 번에 음식물을 처리할 수 있도록 해 음식물 쓰레기 처리의 번거로움을 덜었다는 점에서 눈길을 끈다. 또한 **메인 모터와 배기 FAN에 BLDC모터**를 적용하여 내구성을 향상시키고 전력 소모 및 소음도 획기적으로 줄였다. 럭셔리한 실버 컬러의 스탠드형 디자인은 편의성 뿐 아니라 주방 인테리어까지 업그레이드시켜 인기를 끌고 있다.

Agenda

1 The world market for motors in appliances

2 VFD trends in MHA & SHA applications

3 Smart motor control solution

4 Design support

Constantly growing feature set in small & major home appliance applications

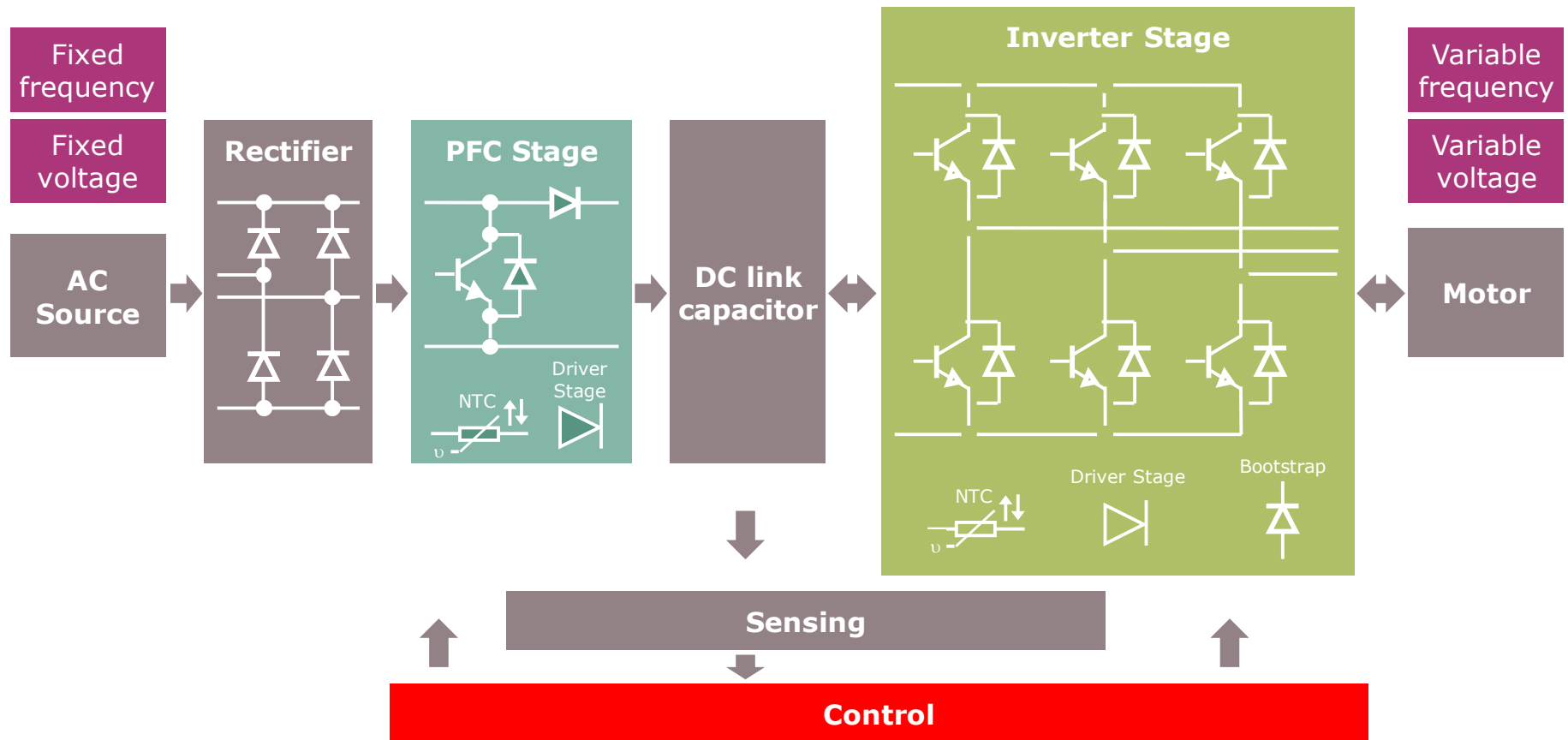

■ IPM ■ iMOTION™ ■ IPM / IGBT, Diode, Gate IC

Intelligent Power Module (IPM) integrates complete inverter stage in one compact package

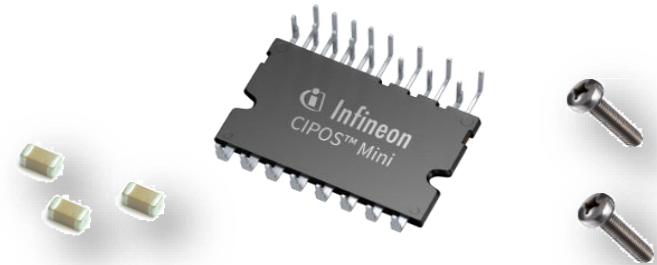
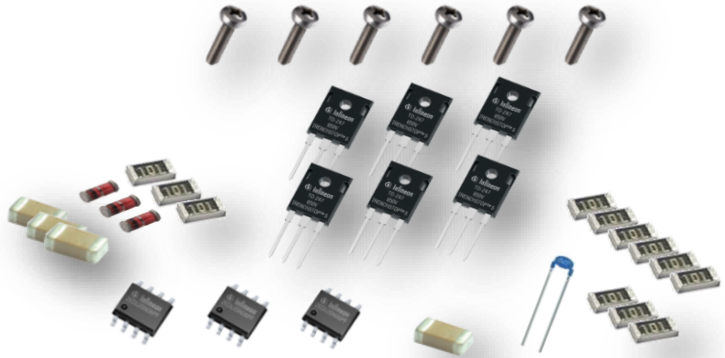

Discrete Solutions

Strong benefits of IPM drive IPM demand increase from various applications

- *Easy of use, higher Integration of additional features*
- *Fast time to market*

IPM

Fewer external components

Significant **PCB space saving**

Improved **manufacturing** process

System cost reduction

Improved **efficiency** and **reliability**

Faster time to market

CIPOS™ IPM Product Portfolio

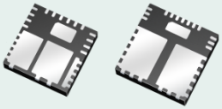
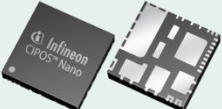
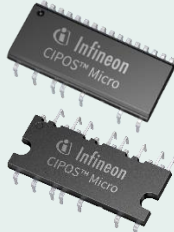
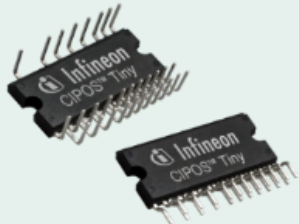
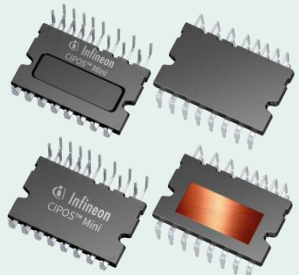
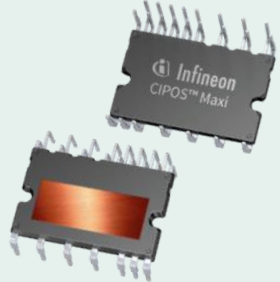

: completing line-up for broad application coverage

CIPOS™ Nano	CIPOS™ Micro	CIPOS™ Tiny	CIPOS™ Mini	CIPOS™ Maxi
Compact IPM	Standard IPM		Performance IPM	
Space constrain	Cost sensitive	Cost & performance	Performance & integration	High power
7x8x0.9 mm 8x9x0.9 mm  12x12x0.9 mm 	29x12x2.9 mm 	34 x 15 x 3.8mm 	36 x 21 x 3.1mm 	36 x 23 x 3.1mm 
	<i>Entry level DIP packages</i>	<i>DIP / SIP packages</i>	<i>Customization possible to win unique opportunities</i>	<i>Customized solutions & highest functionality as key enabler</i>
All MOSFET Half-bridge: 40/100/250/500V 3-phase inv.: 250/500V Smart IPM	MOSFET: 250/500V IGBT: 600V 3/4/6A	IGBT 600V 6A – 20A	IGBT 600V 4A-30A 3-phase inverter, PFC, SRM, Inv + PFC	IGBT 1200V 5A/10A

CIPOS™ Mini Product Overview

DIP 36x21

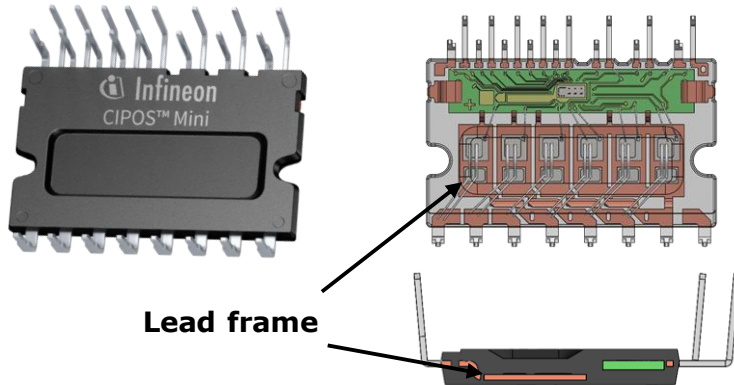

DIP 36x21D

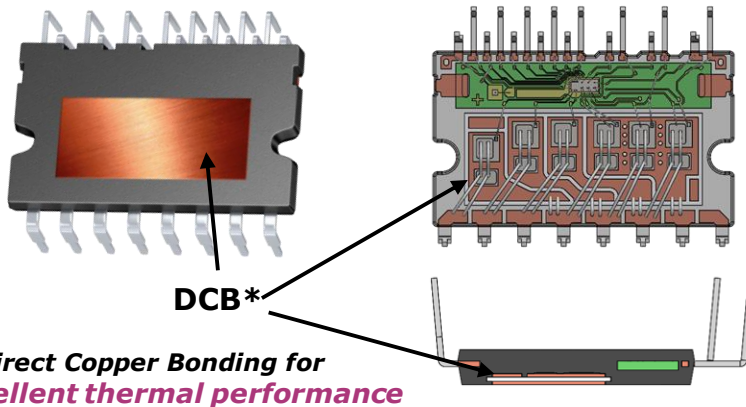

***: Direct Copper Bonding for Excellent thermal performance**

Overview

- › Fully isolated dual-in-line transfer molded package
- › Body size **36 x 21 x 3.1** mm with 24 pins
- › Wide range of current rating : **4A to 30A**
- › Broad range of applications : inverter to PFC
- › Two kinds of package types:
DIP 36x21 and **DIP 36x21D with DCB** substrate

Product line up

Inverter	600V 4A, 6A, 10A, 15A, 20A, 30A 600V 0.33Ω	DIP 36x21
	600V, 15A, 20A, 30A	
SRM	600V 15A, 20A	DIP 36x21D
PFC	650V 20A, 30A	
PFC + Inverter	600V 10A, 15A, 20A*	

***: Under development**



CIPOS™ Mini IPM Product Coverage

Broad range of applications from inverter to PFC

Inverter

- > 3 phase inverter
- > 4 ~ 30A
- > Home appliances and motor drives motor power up to 3kW

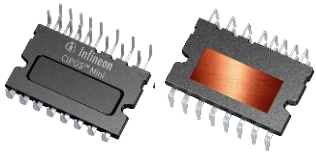

Asymmetric Inverter

- > 2 phase asymm. inverter for switch reluctance motor (SRM)
- > 15A, 20A
- > Unique IPM for SRM : such as vacuum cleaner

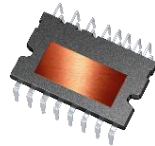

PFC

- > 2 or 3 phase interleaved power factor correction (PFC)
- > 20A or 30A
- > Easy heatsink mounting in combination with Mini inverter IPM

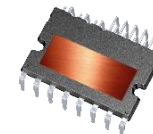

Inverter + PFC

- > Inverter + PFC in one package
- > 10 or 15A
- > System size reduction with PFC integration into inverter module

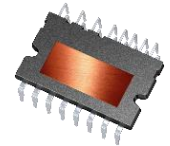

Infineon Offers Variable Speed Motor Drives

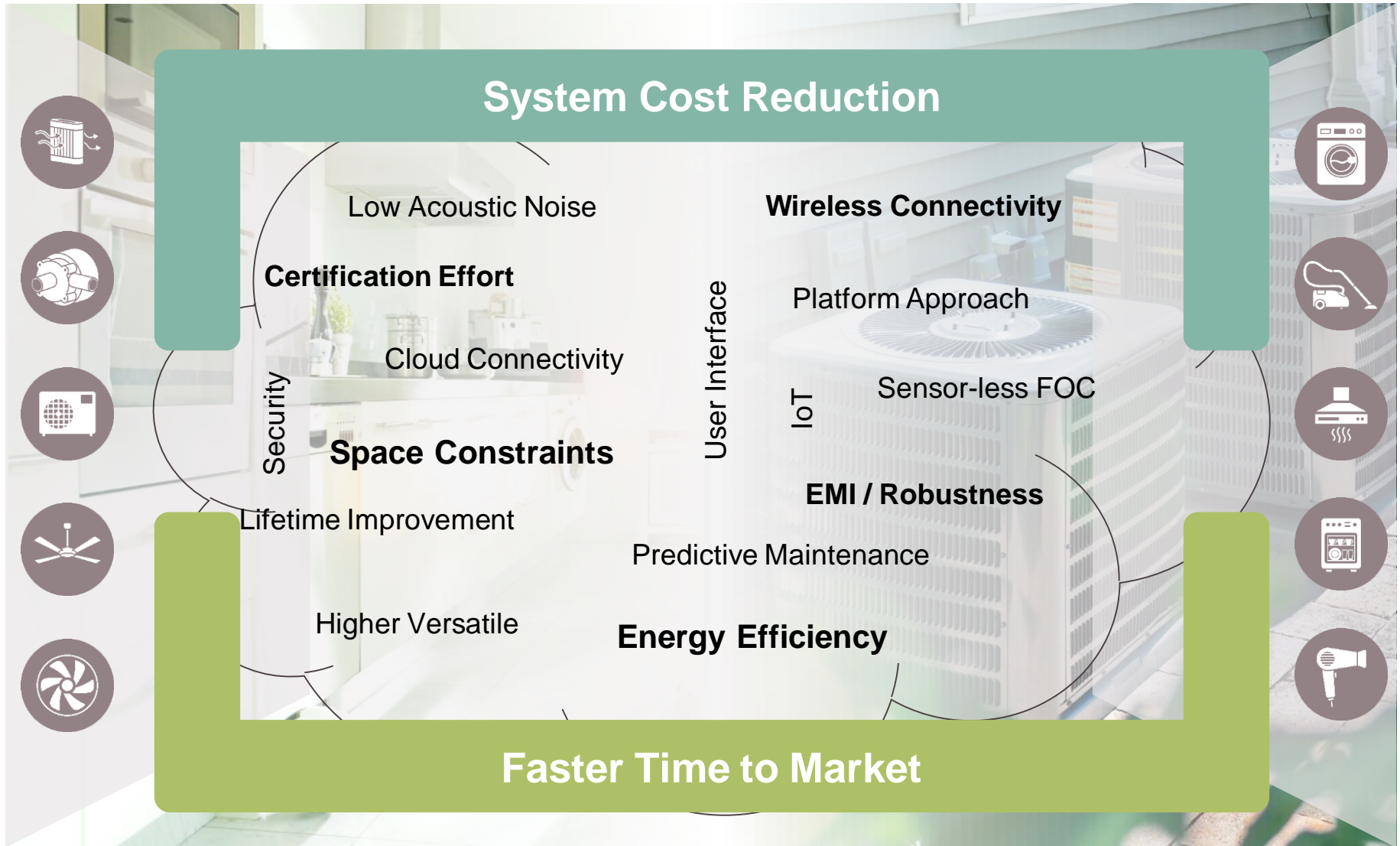

What is iMOTION™ ?

iMOTION™

Solution Platform Dedicated to Motor Control

established in
2006

>30 productive
parts

High Volume
Production

Target Applications

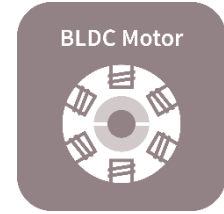
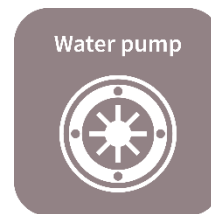
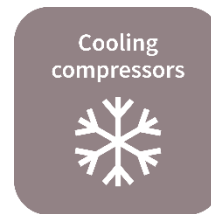
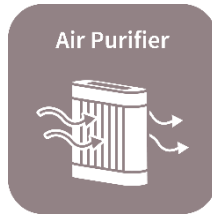

Motion Control Engine (MCE)

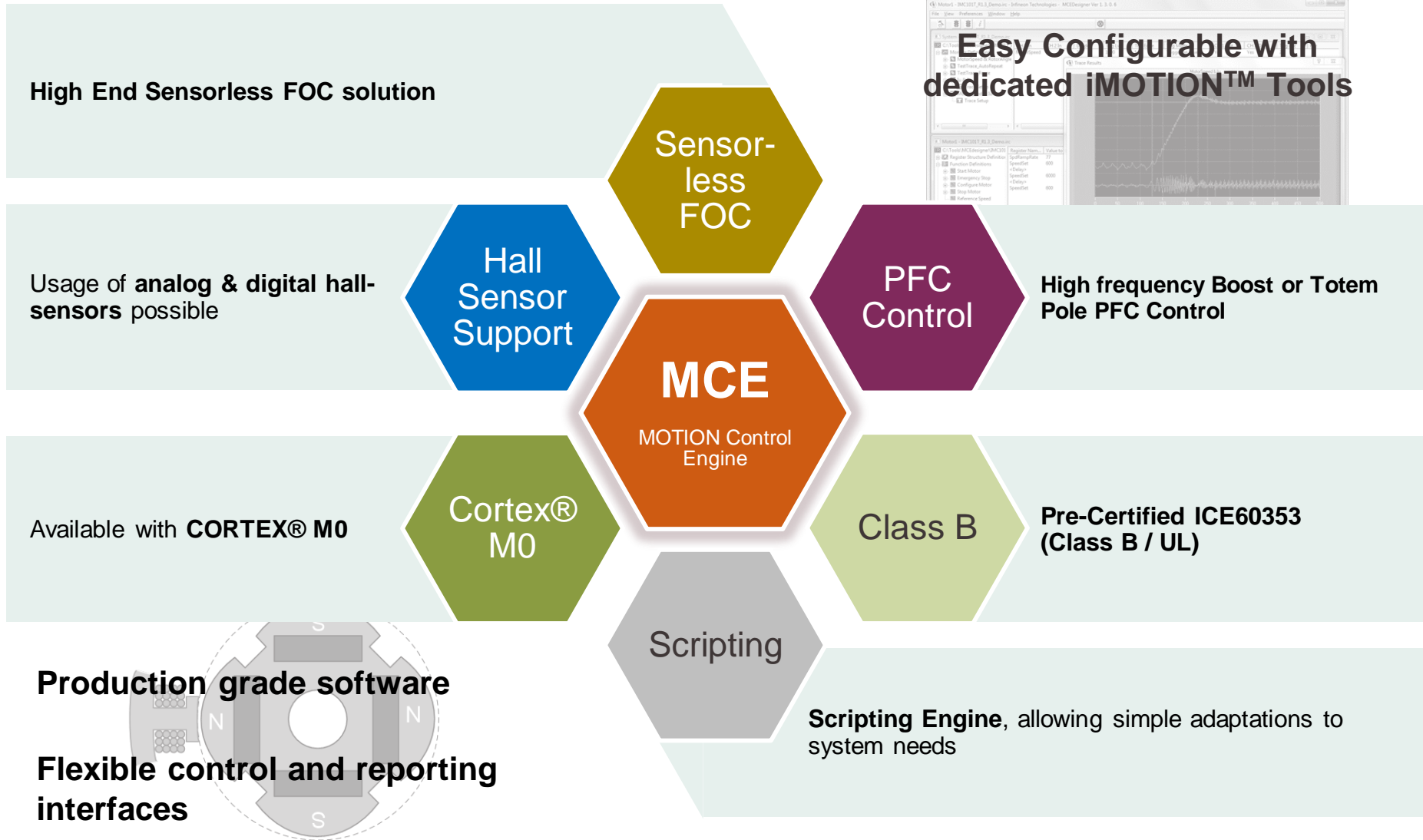

iMOTION™ reduces significantly time & resource needs in the overall motor & PFC software development cycle

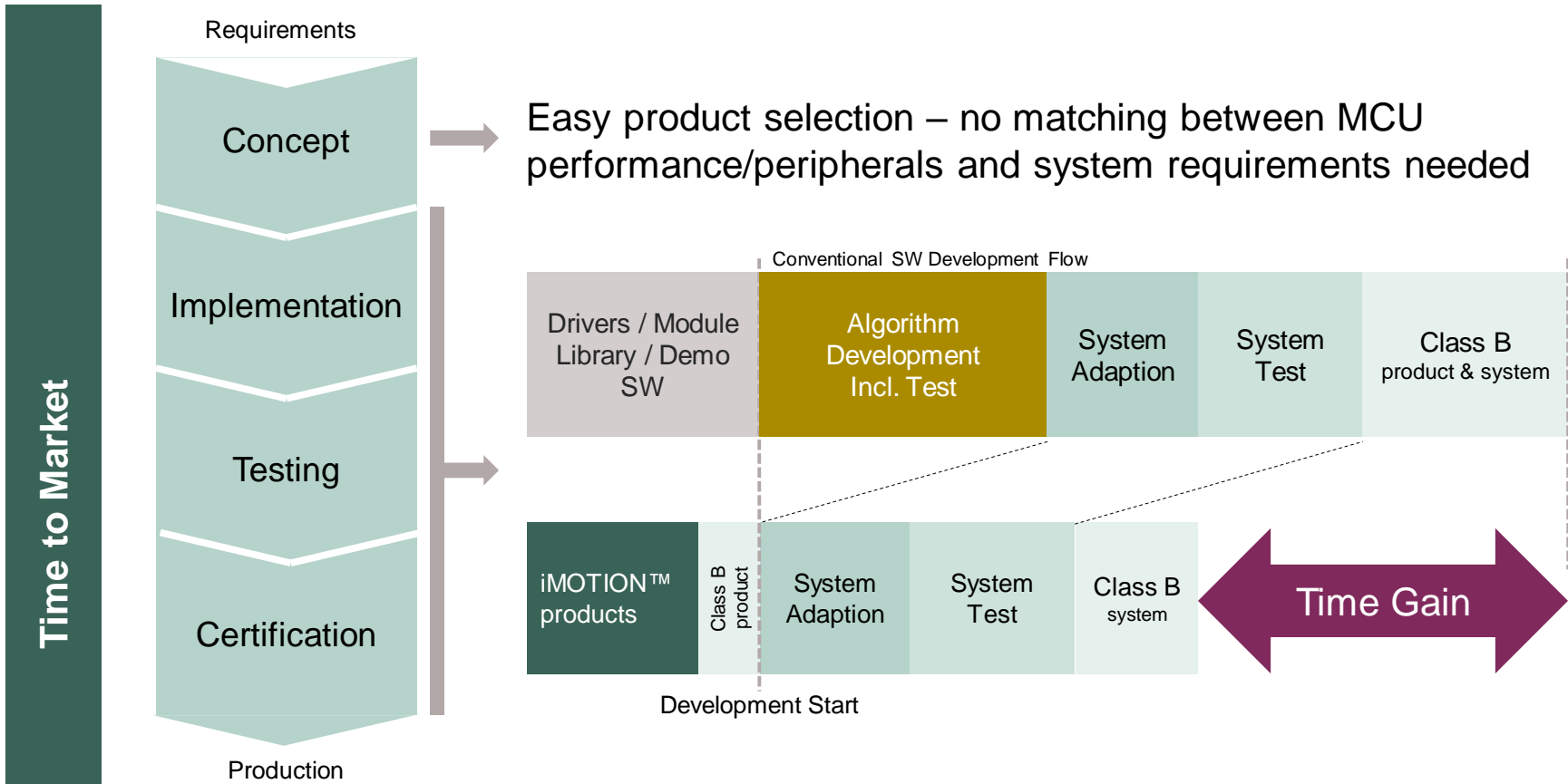

Major benefits – Significant time to market improvement

- > Simplified product selection
- > State of the art algorithms – production ready & UL/ClassB pre-certified
- > RnD Cost savings of ~180k\$ (Assumption: 12MM a 15k\$)

iMOTION™ Tools Easy Setup and Tuning



Get any motor running in less than 1 hour

- › **PC Tools** for easy drive setup and tuning
- › Download latest motor control software (MCE) from Infineon website
 - › Guaranteed compatibility via Secure Chip-ID
- › **Three easy steps** to get the drive up and running
 - › Generate initial parameters for motor (& PFC)
 - › Download parameter set to Evaluation Board
 - › Start, monitor & fine-tune the motor drive

MCEWizard

- › Generate initial drive control parameters
- › Guiding through several self-explanatory questions

MCEDesigner

- › Program and update MCE and drive parameters
- › Control, monitor and tune the drive

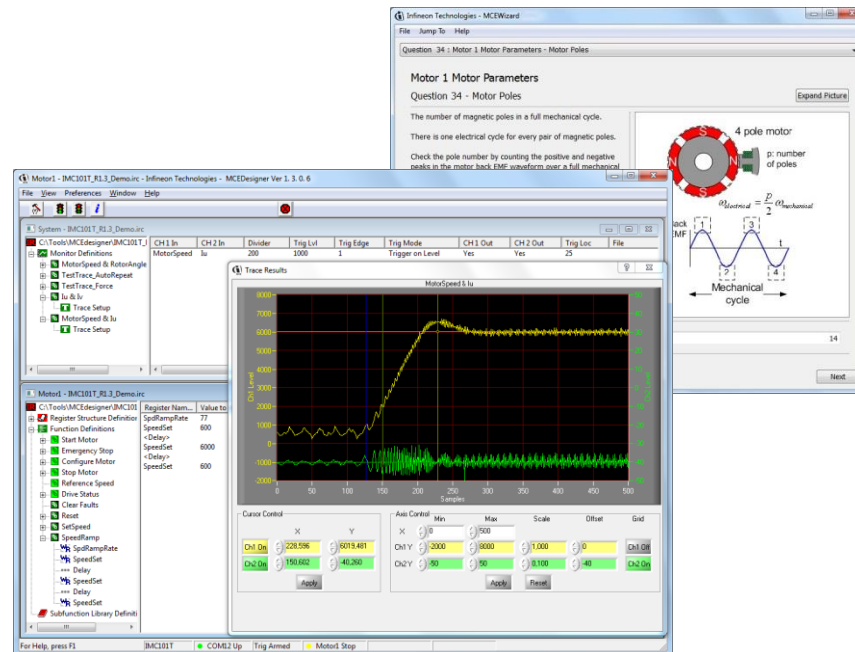

iMOTION™ - a motor control platform with scalable integration of HW and SW



Integration

Flexibility

iMOTION™ Controller

iMOTION™ Smart Driver

iMOTION™ Smart IPM

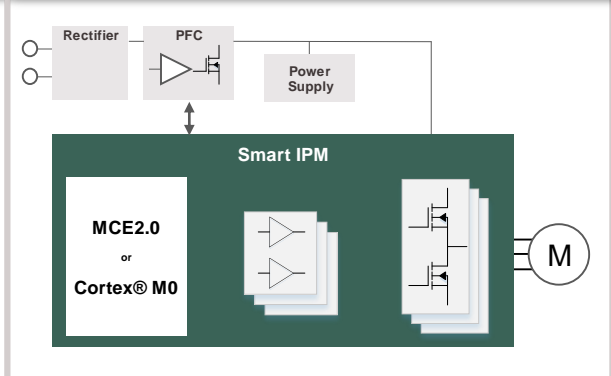
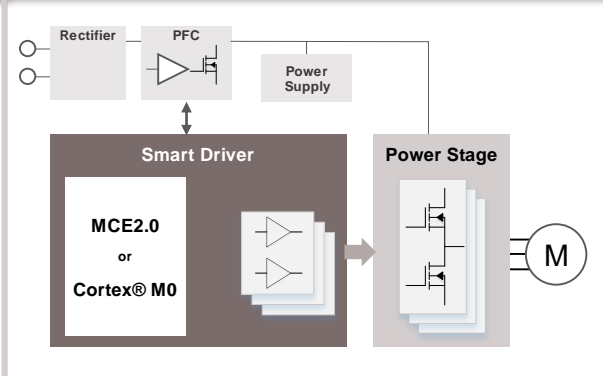
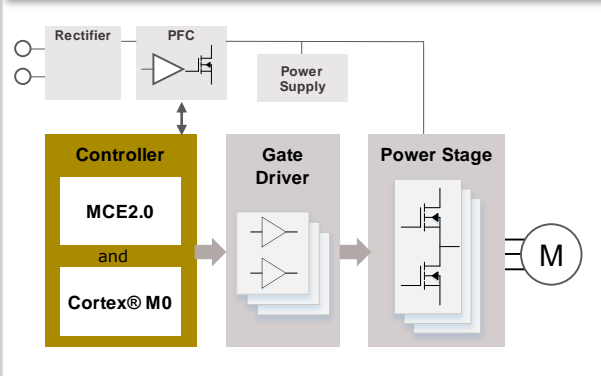

Digital Controller
MCE2.0 and CORTEX® M0

Digital Controller
MCE2.0 or CORTEX® M0

Digital Controller
MCE2.0 or CORTEX® M0

Controller + Gate Driver + MOSFET's

+600V Gate Driver

+600V Gate Driver

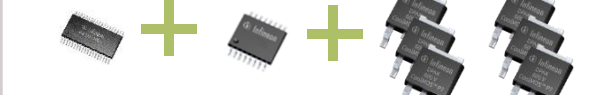

+3ph 600V MOSFET power stage

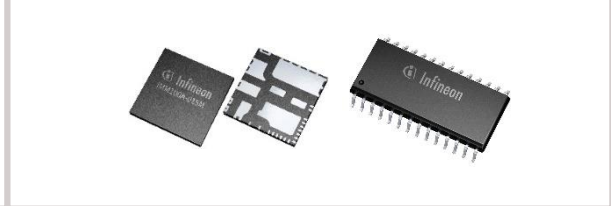
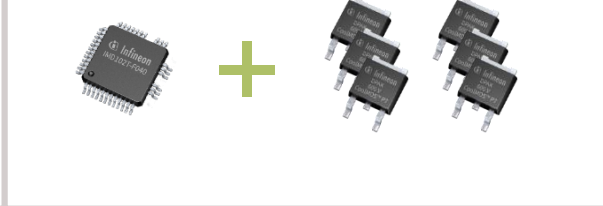
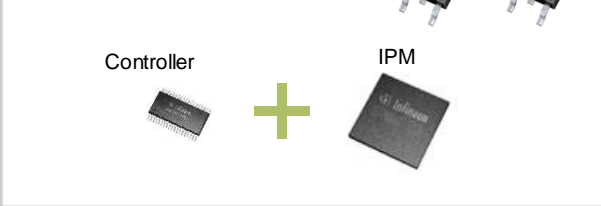

Hardware Integration

Example: IMM100A – up to 100W Full Inverter in One-Package

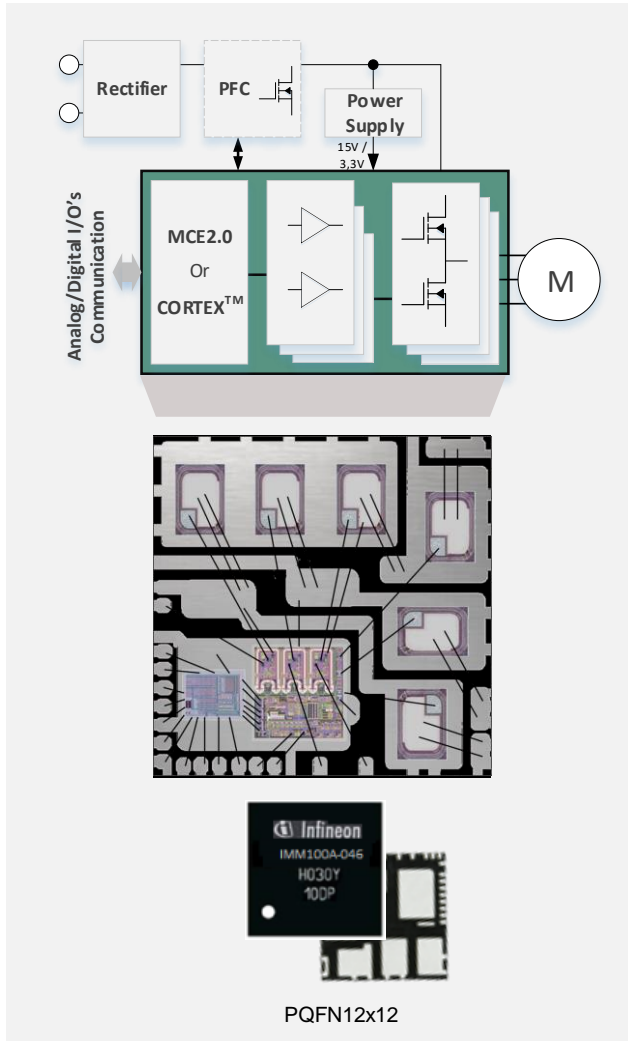

Impact on PCB size & # of components

<p>Traditional IPM Solution</p>		<ul style="list-style-type: none"> > Leaded power package > 2 side-mounted PCB as controller sits on the back side
<p>Solution going to CIPQOS™ Nano</p>		<p>Step1:</p> <ul style="list-style-type: none"> > SMD power package (PQFN) > Controller still separate package <p>> significant PCB space savings</p>
<p>Solution with iMOTION™ Smart IPM</p>		<p>Step2:</p> <ul style="list-style-type: none"> > Full Integration in PQFN > Only discrete / supply components separate <p>> significant PCB space savings</p> <p>> reduced component count</p> <p>> simplified logistic</p>

iMOTION™ provides the flexibility to increase PFC Frequency allowing inductor and system cost reduction.

Example using high frequency Boost PFC

iMOTION™ algorithms support high PFC frequencies. Reduction of inductor costs/space on traditional Boost PFC topologies.

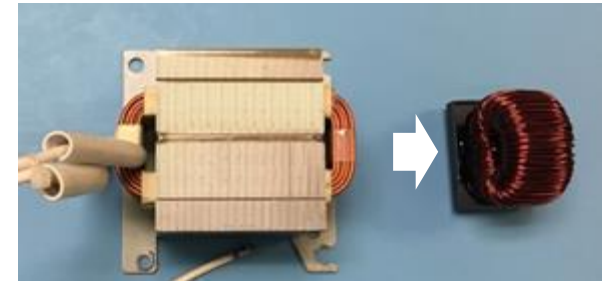
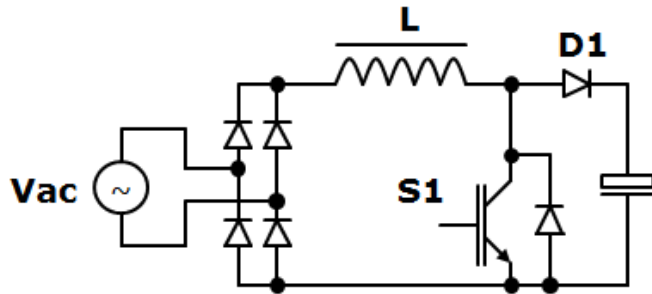

Examples (2kW system) shows inductor size improvement going from 24kHz to 42kHz. Higher frequency is possible (subject to trade off between heat dissipation versus F_c of PFC)

Major benefits

- › Reducing inductor cost up to 50%
- › Simplified assembly (off board → on board mounting)

Example. Controller + PFC integrated IPM

***1 hour or less,
get a motor running !***

**iMOTION™
MADK control boards**

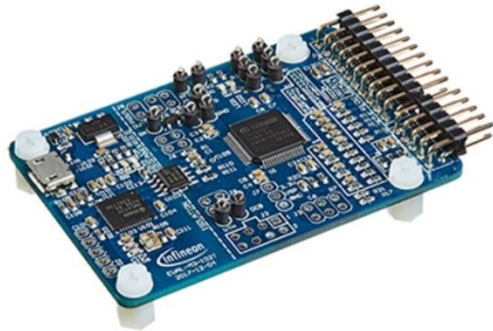

**EVAL-M3-102T
IMC102T-F064
iMOTION™ 2.0
SP001780582**

M3 Platform Interface

CIPOS™ Mini IPM

**EVAL-M3-CM615PN
CIPOS™ Mini with PFC integrated IPM,
IFCM15P60GD, 600V
SP001823760**

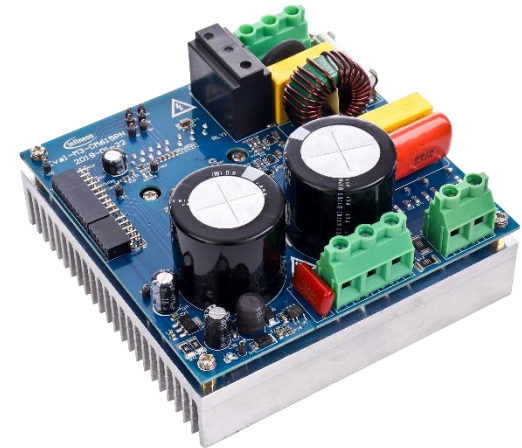

***Compact and flexible
motor drive solutions***

Agenda

- 1 The world market for motors in appliances
- 2 VFD trends in MHA & SHA applications
- 3 Smart motor control solution
- 4 Design support

IFX comprehensive offers for Motor control

Simulation tool

- > Thermal simulation
- > Electric simulation
- > Sensor simulation

Solution

- > PDH
- > Complete solution

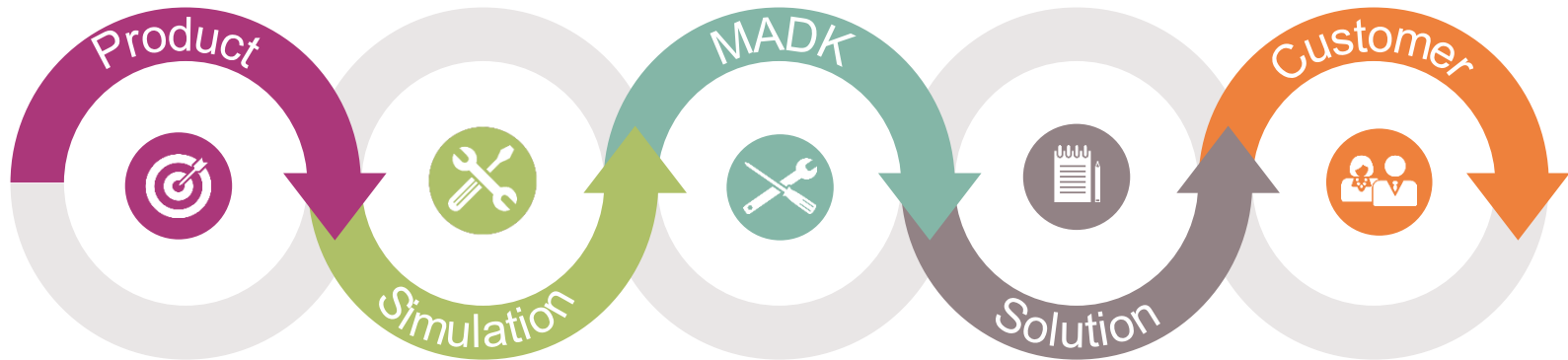

Product

- > iMOTION™
- > CIPOS™
- > Discrete, GD
- > SMPS, sensors

MADK

- > Controller board
- > Power board

Customer

- > On-site engineering support
- > IFX labs in X'ian, Pavia, ELS

MADK Platform

Description

- > **Modular** and **scalable** evaluation platform for PMSM motors
- > Wide range of **control and power boards**
- > Integrated **Motion Control Engine (MCE)** - No programming required – ready-2-run
- > Galvanic **isolated USB debug interface** for safe connection to PC
- > Easy motor setup and control using iMOTION™ MCEWizzard and MCEDesigner tools
- > Various test points for testing and debugging

Controller Boards

EVAL-M3-102T

- > Controller: IMC102T-F064
- > Motor and PFC control
- >  M3 Interface Connector















EVAL-M1-101T

- > Controller: IMC101T-T038
- > Single motor control
- >  M1 Interface Connector



Power Boards

M3
M1

	EVAL-M1-E1B1245N-SiC	EASY1B CoolSiC™ MOSFET FS45MR12W1 *2; 1200V		11kW 6kW
	EVAL-M1-E1B1235N	EASY1B FS35R12W1 *2; 1200V		3kW
	EVAL-M1-CM610N3	CIPOS™ Mini IKCM10H60GA; 600V		750W
	EVAL-M3-CM615PN	CIPS™ Mini with PFC IFCM15P60GD; 600V		650W
	EVAL-M1-IM393-?	CIPOS™ TINY 600V		600W
	EVAL-M1-05F310	CIPOS™ Nano IRSM005-310MH; 100V		300W
	EVAL-M1-05-65D	CIPOS™ Micro IRSM505-065DA2; 500V		250W
	EVAL-M1-05-84D	CIPOS™ Micro IRSM505-084DA2; 250V		250W
	EVAL-M1-05F804	CIPOS™ Nano IRSM005-800MH; 40V		200W
	EVAL-M1-36-45A	CIPOS™ Nano IRSM836-045MA; 500V		80W
	EVAL-M1-36-84A	CIPOS™ Nano IRSM836-084MA; 250V		20W

Output Power

IFAP PDH

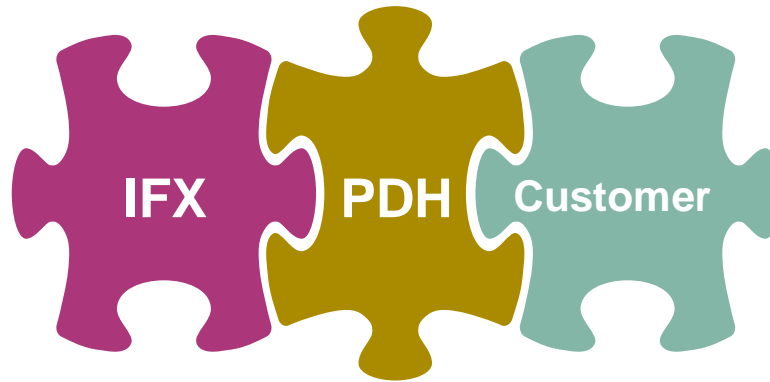
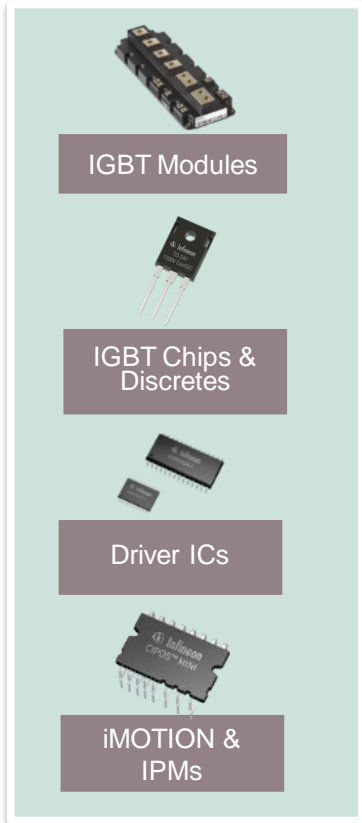

- > PCB design
- > Sub-system design
- > Demo board
- > Testing
- > Qualification
- > Others

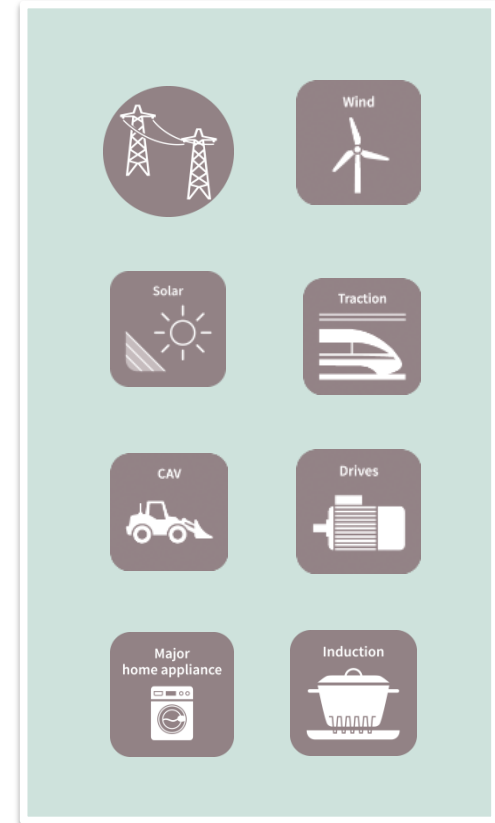

Partnering is key to address:

- Faster time to market
- Broadens customer base by connecting them to desired expertise / services



Part of your life. Part of tomorrow.