

Go battery-less

The first multi-standard wireless MCU platform for the IoT



Launching Feb. 25, 2015

Low power, easily connected IoT applications

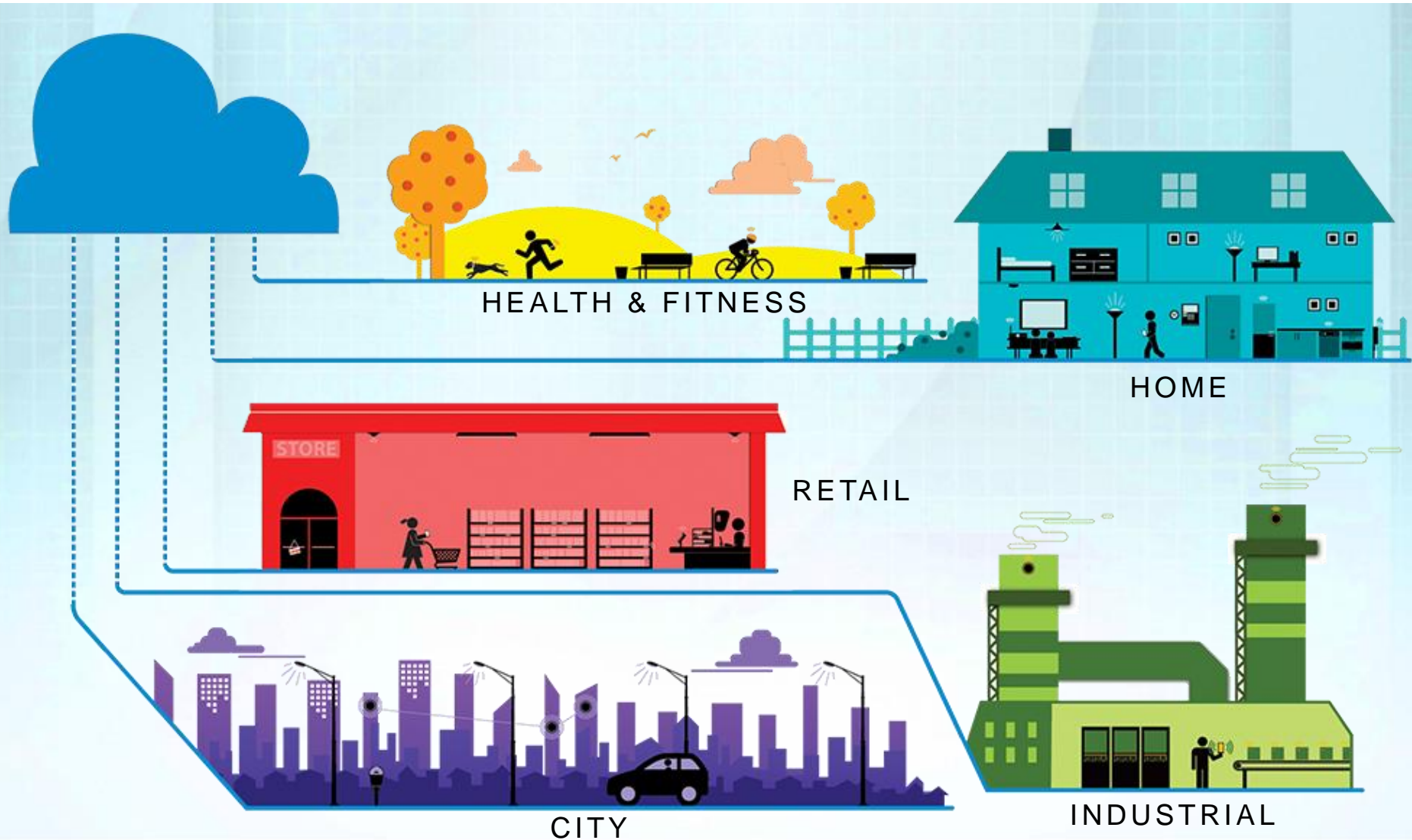

Expanding the SimpleLink wireless connectivity portfolio with ultra-low power MCUs

The lowest power

- Multi-year, always-on operation with a coin cell battery
- Go battery-less with energy harvesting
- Integrated ultra-low power sensor controller



Industry's only multi-standard platform

- Code and pin compatibility across:
 - *Bluetooth*[®] Smart
 - 6LoWPAN
 - ZigBee[®]
 - Sub-1 GHz
 - ZigBee RF4CE[™]
 - Proprietary modes up to 5Mbps



Easiest to design with

- Minimal RF experience required
- Ready to use protocol stacks and TI-RTOS
- Programmable ARM[®] Cortex[®]-M3 based MCU
- Simplest RF & antenna design
- Built-in robust security
- Tools and reference designs



Low-power operation

1 When processing with MCU

- Fast processing using less than 3.3 mA @48MHz
- Less time used for stack and application processing and BLE connection events

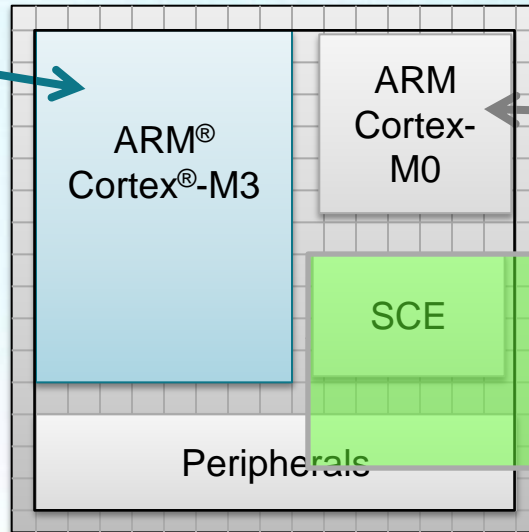
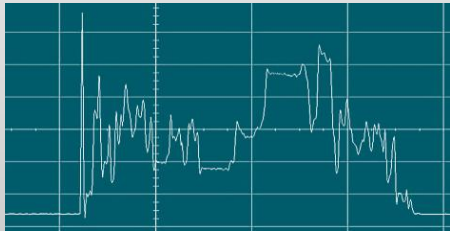

Sleep Current:

- 1 μ A Sleep with RTC and full retention
- Less than 0.1 μ A in Shutdown

2 When in sleep

4 When radio is in Receive or Transmit

- ~6mA RX / TX current

3 When peripheral is polled for data

- Sensor controller and its peripherals can be powered while rest of system is power off.
- Run Sensor Reading with < 3 μ A current consumption



The lowest power: 1/2 the power of other MCUs

Designed for low-power operation

- Multi-year on a coin cell battery or use energy harvesting
- Faster processing
- Power-optimized radio
- Ultra-low sleep current
- Less than 0.15 μA in shutdown
- Only MCU with integrated sensor controller

Ultra-low power

| When | Parameter @ 3V | Value |
|---------------------|--|------------------------------|
| While processing | ARM® Cortex®-M3 Running CoreMark | 61 $\mu\text{A}/\text{MHz}$ |
| | Peak current @ 48MHz CPU Running CoreMark | 2.9 mA |
| | Coremark @ 48MHz CPU | 142 |
| While communicating | Peak current RX | 5.9 mA |
| | Peak current TX | 6.1 mA |
| While sleeping | $\mu\text{A}/\text{MHz}$ on sensor controller | 8.2 $\mu\text{A}/\text{MHz}$ |
| | Sleep mode with RTC and full memory retention | 1 μA |

Best-in-class ULPBench score of 143

ULPBench Scores

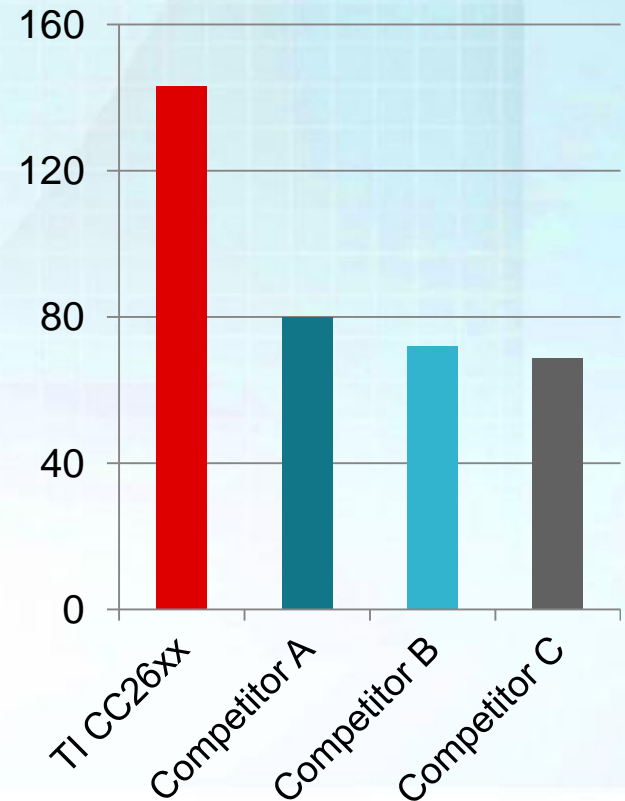

Multi-standard: Five technologies, one architecture

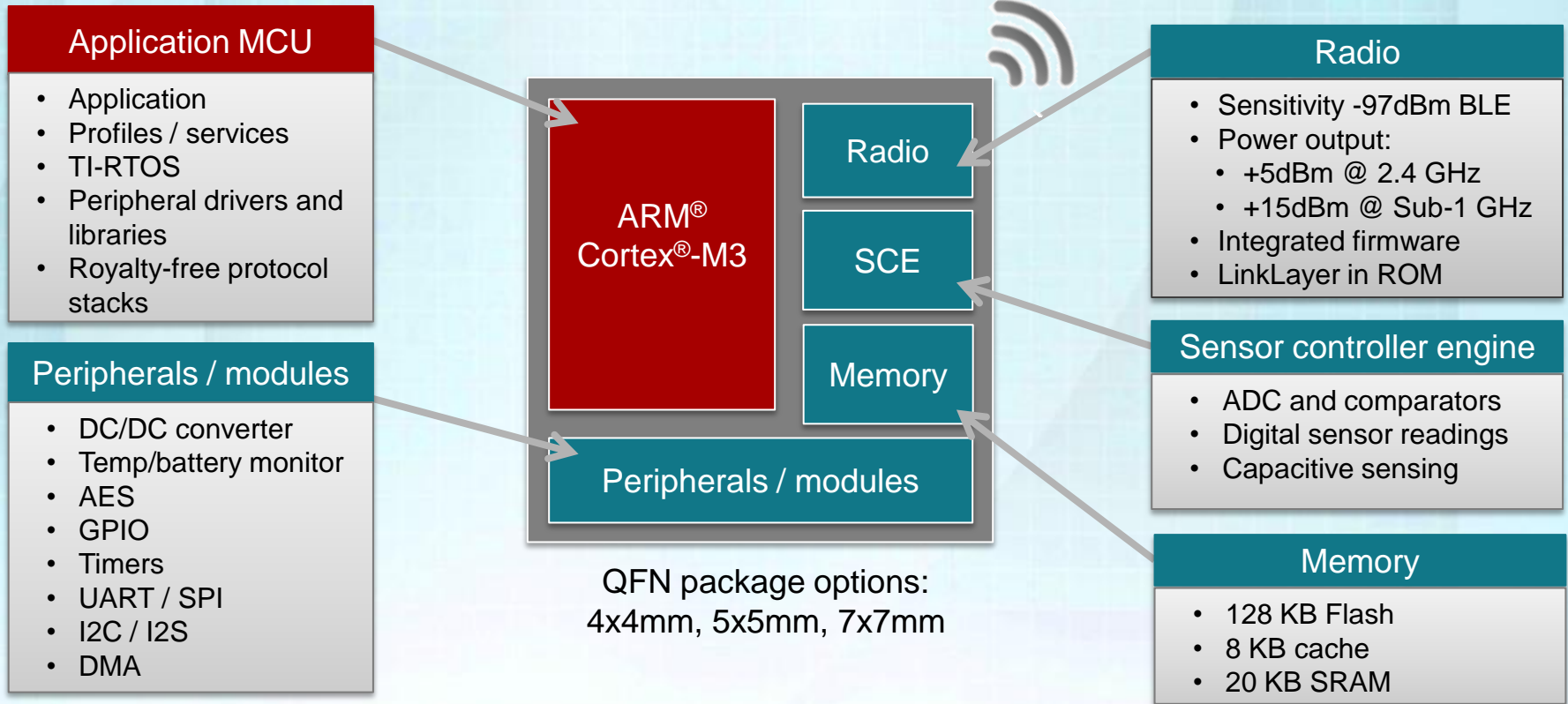

SimpleLink ULP platform: The first three solutions



Bluetooth Smart



6LoWPAN / ZigBee



Multi-standard

CC2640 wireless MCU for Bluetooth Smart support



Easy multi-year support for IoT applications in a tiny package

- Lowest power Flash-based Bluetooth 4.1 solution with multi-year operation on smaller coin cells
- Finger-tip sized one-chip system integrating a Flash-based MCU and Bluetooth Smart radio
- Robust, royalty-free software stack with over-the-air update capability to support evolving standards and comprehensive design tools

CC2630 wireless MCU for 6LoWPAN/ZigBee support



Power a cloud-connected light switch for 10 years with a coin cell battery

- Enable battery-operated mesh networks or energy harvested nodes: Power a light switch for 10 years with a coin cell
- Connect 1,000's of mesh network nodes in homes, buildings and cities with a portfolio of 802.15.4-based solutions
- Easily connect to the cloud and Internet through 6LoWPAN operation – each device includes an IPv6 address

CC2650 wireless MCU for multi-standard support



Future-proof:
Switch between
multiple 2.4 GHz
technologies with
only one design

- Flexibility to develop Flashed-based solutions that support multiple technologies with the same architecture:
 - Bluetooth Smart, 6LoWPAN, ZigBee and RF4CE
- Go to production without locking in a selection and configure chosen technology at the time of installation in the field

SIMPLELINK ULP PLATFORM: LAUNCHES COMING THROUGHOUT 2015

2Q '15



CC1310: Sub-1 GHz

- Pin-to-pin compatible with CC26xx
- For long-range up to 25 km, city-wide low power networks
- Operation in 315 MHz, 433 MHz, 470 MHz 500 MHz, 868 MHz, 915 MHz and 920 MHz ISM bands

3Q '15



CC2620: RF4CE

- Lowest power RF4CE solution enabling coin cell battery powered remotes
- Most integrated voice enabled remote solution
- Integrated capacitive sensing for remote and TV/STB buttons and touchpads

4Q '15



CC1350: Dual-band

- Most versatile & integrated radio for 2.4 GHz and Sub-1 GHz operation on the same chip
- Enables long range Sub-1 GHz networks to be connected with Bluetooth Smart
- MCU supports Sub-1 GHz, Bluetooth Smart, 6LoWPAN, RF4CE & proprietary modes up to 5Mpps





CC2640 *Bluetooth Smart*

"CC2640 puts Smart in Bluetooth SMART"

CC2640

TI introduces the next generation platform

Improving the three key challenges for a *Bluetooth* low energy product:

| Easiest to design with  | Lowest Power  | Most Integrated  |
|--|---|---|
| <ul style="list-style-type: none">• Qualified BT 4.1 Bluetooth Smart• Get-Started Documentation & Wiki• Dynamic Design Kits • Low-cost Tools | <ul style="list-style-type: none">• ~ 6mA Radio peaks and 1uA Sleep• ~ 61µA/MHz ARM Cortex M3• <10 uA avg. Current @ 1s Conn. Int• Sensor Controller Engine (SCE) | <ul style="list-style-type: none">• 4x4 QFN• On-Chip Flash• Single Ended Output• Integrated DCDC |
| <i>Comprehensive Design Support</i> | <i>Multi-year operation on a coin cell</i> | <i>Complete Bluetooth Smart system on a finger-tip size</i> |

"CC2640 puts Smart in Bluetooth SMART"

Software Platform CC2640

Royalty free from TI, ready for application development

Over-the-air download

The FLASH can be partially updated over-the-air, which means that the application can be updated separately from the BLE stack.

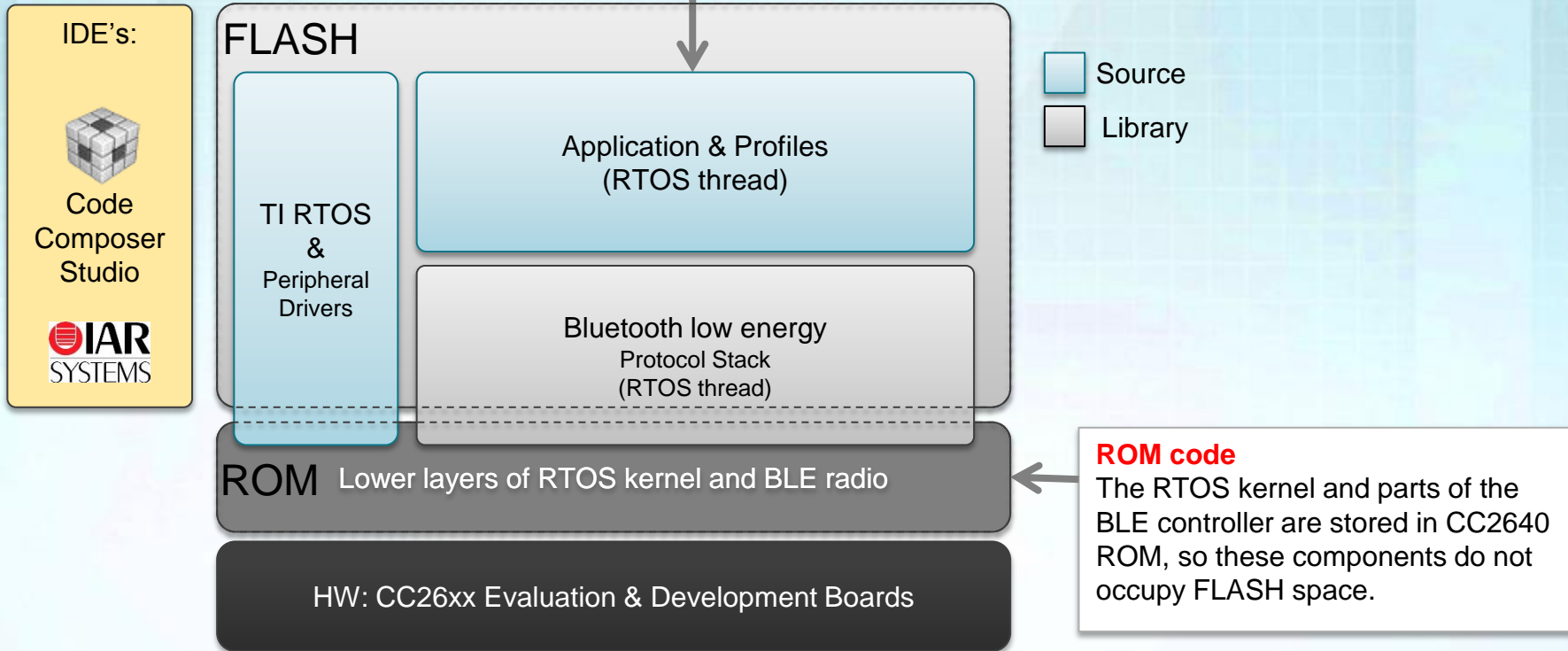

ROM code

The RTOS kernel and parts of the BLE controller are stored in CC2640 ROM, so these components do not occupy FLASH space.

BLE-Stack™ v2.0

- **Mature and Robust Software Package**

- Golden unit for Bluetooth low energy interoperability test
- Fully BT 4.1 Qualified Solution

| Example Application | Description |
|----------------------|--|
| SimpleBLEPeripheral | Generic Peripheral using proprietary Profile example |
| SimpleBLECentral | Generic Central |
| SimpleBLEBroadcaster | Generic Broadcaster |
| SimpleBLEObserver | Generic Observer |
| SensorTag | SensorTag 2.0 Firmware |
| HostTestApp | Wireless Network Processor (Application via SPI/UART) |
| BloodPressure | Example using Blood Pressure Profile (BSP) |
| CyclingSensor | Example using Cycling Speed and Cadence Profile (CSCP) |
| GlucoseCollector | Example using Glucose Profile (GLP) as Collector |
| GlucoseSensor | Example using Glucose Profile (GLP) as Sensor |
| HeartRate | Example using Heart Rate Profile (HRP) |
| HIDemuKbd | Example using HID over GATT Profile (HOGP) |
| ProximityTag | Example using Proximity Profile (PXP) |
| RunningSensor | Example using Running Speed and Cadence Profile (RSCP) |
| Thermometer | Example using Health Thermometer Profile (HTP) |
| TimeApp | Example using Time Profile (TIP) |

Additional Services

Proprietary

Accelerometer
Barometer
Gyrometer
Humidity
IR Temperature
Magnetometer
Movement
Optics
Connection Control
Simple Keys

BT SIG Adopted

Find me
Alert Notification
Battery Status
Device Information

Radio Frontend *Flexibility*

Best Performance

- Differential, external bias
- 5 dBm output power
- -97 dBm BLE sensitivity

Smallest Footprint

- Single ended, external bias
- 2 dBm output power
- -96 dBm BLE sensitivity

Other options are available. Internal biasing reduces BOM by one inductor at the cost of 1 dB sensitivity

NB! Differential External bias is not supported on 7x7

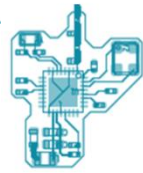
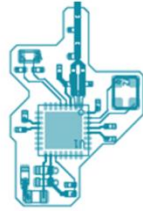
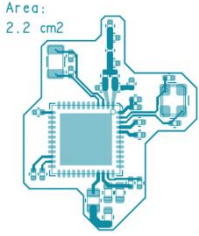



| Evaluation Module | | CC2650EM-4XD | CC2650EM-5XD | CC2650EM-7ID |
|-------------------------|--------------|---|---|---|
| CC2650 Package Type | | 4x4 | 5x5 | 7x7 |
| Pitch [mm] | | 0.4 | 0.5 | 0.5 |
| GPIOs | | 10 | 15 | 31 |
| RF Frontend Option | | Single Ended External Bias | Differential External Bias | Differential Internal Bias |
| Area [cm ²] | | 1.3 | 1.5 | 2.3 |
| Design Example | Illustration |  |  |  |
| | Crystals | 2 | 2 | 2 |
| | Capacitors | 14 | 17 | 18 |
| | Inductors | 3 | 6 | 5 |
| | Resistors | 1 | 1 | 1 |
| Total | | 20 | 26 | 26 |

CC2630

ZigBee / 6LoWPAN

Introducing CC2630

TI introduces the next generation platform for low power mesh networks and IoT applications

| Easiest cloud connectivity  | Lowest Power  | Easiest mesh plug-in  |
|--|---|--|
| <ul style="list-style-type: none">• End to end solution from sensor to cloud• Get-Started Documentation and reference design• Integrated Design Kits• Low-cost Tools  | <ul style="list-style-type: none">• ~6.1 mA Radio peaks and 1uA Sleep• 61µA/MHz ARM Cortex M3• <30 mAms avg. charge for polling operation• Sensor Controller Engine (SCE) | <ul style="list-style-type: none">• 4x4 QFN• On-Chip Flash• Network processor• Integrated DCDC• Cross-platform portable SW framework for IoT application |
| <p><i>Plug-in connectivity to the cloud in 10 minutes</i></p> | <p><i>Average system current consumption 2x better than competition</i></p> | <p><i>Compact system design for bolted-on wireless connectivity</i></p> |

Software Platform CC2630

Royalty free from TI, ready for application development

Over-the-air download

The FLASH can be partially updated over-the-air, which means that the application can be updated separately from the stack.

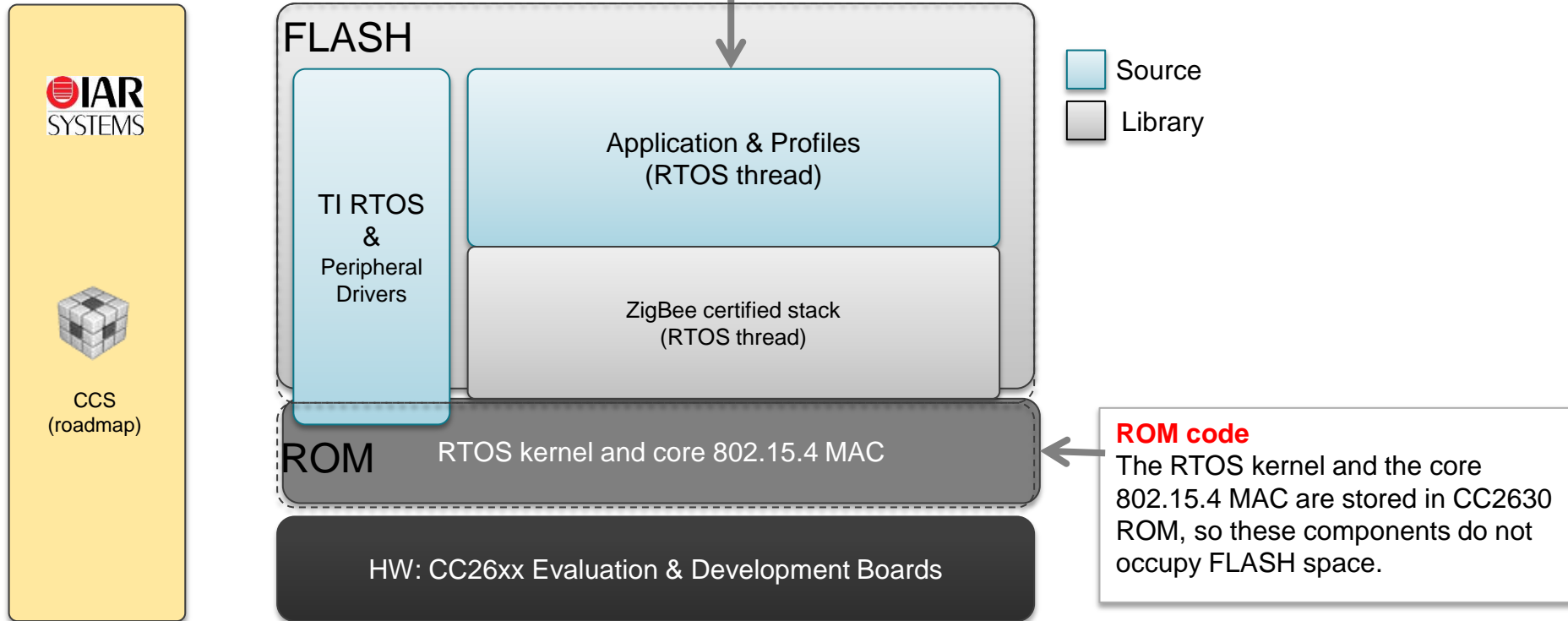

ZigBee solution for Home Automation

- **Mature, rich and complete end to end solution for IoT**
 - Golden unit implementation for any Home Automation end nodes application
 - Certified ZigBee solution
 - Full implementation of an IoT Linux gateway solution with agent
 - ZigBee network processor host SW framework for any MCU: easy wireless add-on
 - Plus, tons of examples for ease of integration

| Example Application | Description |
|--------------------------|--|
| Door Lock | Implementation of a door lock sensor with remote pin code lock/unlock |
| Temperature sensor | Example of a certified temperature sensor application for periodic reporting |
| Thermostat | Temperature monitoring, set heat/cool mode and target points |
| HCU | Implements heating/cooling set commands. Reports status |
| Light | Implementation of a certified white dimmable light |
| Switch | Low power dimmer/toggle switch |
| Local gateway controller | Proxies all devices in the network, monitors and controls |
| Gateway IoT agent | MQTT gateway client for cloud connectivity |
| Command line interpreter | Explorer of all network processor interface |

Hardware Design *Small Form Factor*

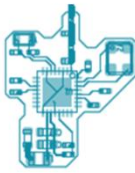
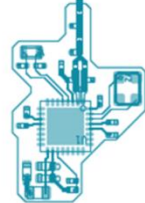
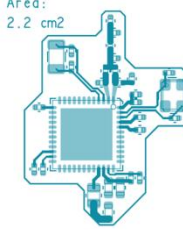
| Evaluation Module | | CC2650EM-4XD | CC2650EM-5XD | CC2650EM-7ID |
|-------------------------|--------------|---|---|---|
| CC2650 Package Type | | 4x4 | 5x5 | 7x7 |
| Pitch [mm] | | 0.4 | 0.5 | 0.5 |
| GPIOs | | 10 | 15 | 31 |
| RF Frontend Option | | Single Ended External Bias | Differential External Bias | Differential Internal Bias |
| Area [cm ²] | | 1.3 | 1.5 | 2.3 |
| Design Example | Illustration |  |  |  |
| | Crystals | 2 | 2 | 2 |
| | Capacitors | 14 | 17 | 18 |
| | Inductors | 3 | 6 | 5 |
| | Resistors | 1 | 1 | 1 |
| | Total | 20 | 26 | 26 |

Sensor controller: Low-power game changer

Sensor Controller engine

- A proprietary low power CPU to offload the M3

Key features

- Handles sensor polling and performs simple processing
- Operates while the rest of the system is in powered down

Examples of sensors that will greatly benefit from using the sensor controller:

- PIR (motion detector)
- Capacitive touch keys
- Proximity sensors
- Accelerometers
- ADC measurements
- Pulse counting

Use Sensor Controller Studio for configuration

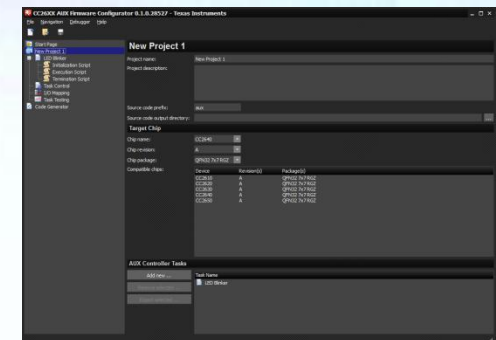
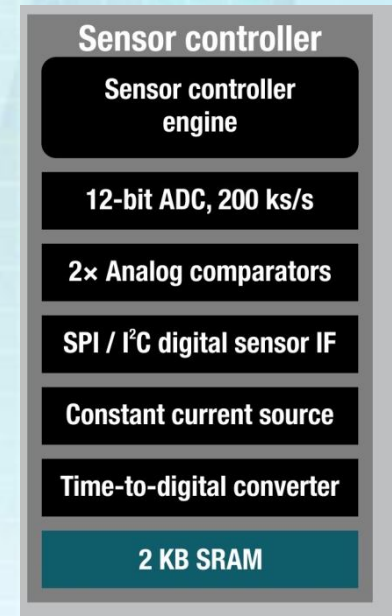

Get started fast: Development kits

Now

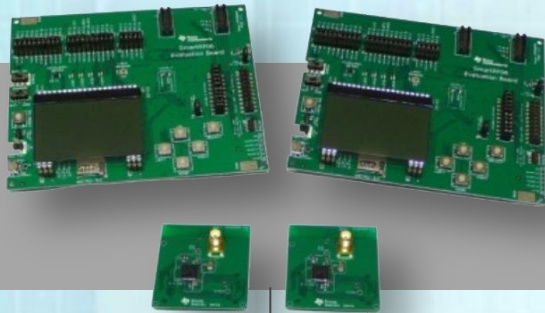

CC2650DK development kit

- Full-feature emulator for development and debugging
- One kit for all 2.4 GHz standards with royalty-free software
- \$299 through the TI Store and distribution
- Additional EMK kits available for \$99

Now



CC2650-based SensorTag kit

- Sensor-based development kit for IoT applications
- Get connected to the cloud in 3 minutes
- Easy programming and prototyping with add-on JTAG daughter card
- Free app for iOS & Android
- \$29 through the TI Store and distribution

2H '15



LaunchPads & BoosterPacks

- Low-cost MCU evaluation kits and plug-in modules for quick development
- Leverages existing TI MCU ecosystem

Easy-to-use: Software, support and more



Software

Common software

Across all SimpleLink ULP products:

- TI-RTOS operating system
- Code Composer Studio integrated development environment
- IAR Embedded Workbench



Royalty-free network stacks

Robust, certified and proven stacks:

- BLE-Stack with OTA support
- Z-Stack™ supporting various ZigBee applications



Support

Comprehensive

Development documentation, guides and wikis available online



E2E online support

TI E2E™ community – answers at your fingertips from engineers



Training

Online videos and other resources to learn more about the parts and tools



And more...



TI reference designs online



TI IoT cloud ecosystem



TI store 24/7

Silicon & kit sales & samples on TI Store

SimpleLink ultra-low power wireless MCU platform

The lowest
power



Industry's only
multi-standard
platform



Easiest to
design with



For more information: www.ti.com/simplelinkulp